



An SVI Brand Product Line

**ENVIRONMENTALLY FRIENDLY
AND SAFE TO OPERATE!**

Operates off of Compressed Air and
Non-Vegetable Based Fluid
Just Like That Used by the US Coast Guard

Since 1928.

Now, it's your turn to own a Globe.

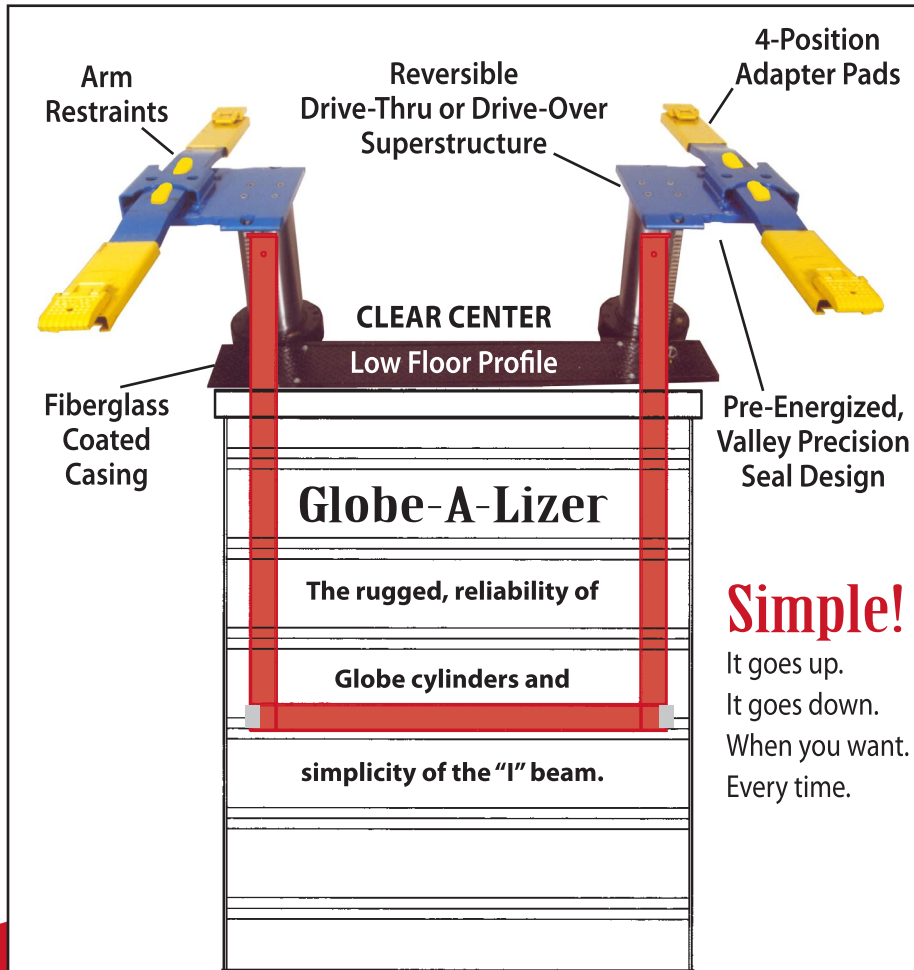

Globe-A-Lizer

The rugged, reliability of

Globe cylinders and

simplicity of the "I" beam.

Simple!

It goes up.
It goes down.
When you want.
Every time.

The lifting is done with  one moving part.

Specifications:

Capacity: 8,000 lbs. @ 150PSI (2,000 lbs. per Adapter)

Operation: "BS" = Full-Hydraulic

Rise: 71-1/2" Floor to Top of the Adapter Pad

Plunger Centers: FSRG = 57-1/2"

Displacement: 36 gallons

Initial Fill: 65 gallons

Cylinder: 8-1/2" Diameter

Superstructure: Solid Steel Bolster-Style and Low Profile Swing Arms

Adapters: Ductile Iron, 4-Position Adjustable on Sliding Sleeves

Low Oil Control and

Auto Lock Leg: Supplied in Accordance with ANSI B153.1 Specifications

Two-Post,
Frame Kontakt
Passenger Car Lift

Model FSR-28BS
(Full-Hydraulic)

- Handles Most Domestic and Imported Models
- 4-Position Adapters Provide Excellent Undercar Accessibility
- Low Profile - 4" Road Clearance
- Ideal in Virtually Any Shop
- Great for Exhaust Work

Applications:

- Car Dealerships
- Tire Dealerships
- Muffler Shops
- Brake Shops
- Tune-Up Centers
- Service Stations
- Body Shops
- Fleet Service
- Quick Lubes
- Car Collectors
- Scrap Yards
- Anywhere Auto

*True Drive-Thru
or Drive-Over
Model*

This model is exempt from
Federal EPA regulation.

In-ground lifts are making a major resurgence due to their solid design and proven service life. Nothing outperforms or costs less to operate than an in-ground lift.

Get in, get one!



STANDARD FEATURE

4-Position Frame Kontakt Adapters

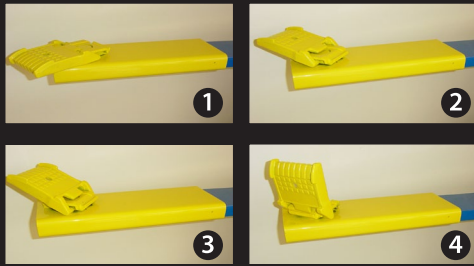

Standard 4-position adapters mean Globe lifts provide the industry's most versatility in reaching proper pick-up points on the vehicles you are lifting.

Reversible Sleeves - Standard Feature

The adapter supporting sleeve can easily be slipped off the swing arm and reversed. This provides even greater flexibility in reaching pick-up points on today's smaller vehicles.

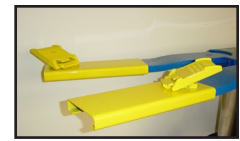

Positive Stabilization

Mechanical heavy-duty racks and pinions equalize plunger movement.

Automatic Locking

Latches automatically engage as the lift is raised. To lower, release locks, and when the lift descends, the locks automatically reset and remain ready for the next job. Optional additional latches can be added easily to provide for more locking positions.

Room to Work

Globe "28" models give you the flexibility and all the room you need for under-the-car repair or service. In your business, accessibility means faster repairs, more cars in and out everyday. Get Globe working for you!



9" without Pad



9" with Pad



7"-10" w/Pad Adjustable

OPTIONAL FEATURES

Height Extensions

Slide height extensions easily onto the Frame Kontakt adapter while in the upright position to provide more versatility in reaching the proper pick-up points.

SUGGESTED WRITTEN SPECIFICATIONS

FUNCTION: To raise domestic and imported vehicles by their frames or bodies permitting maximum undercarriage service accessibility with wheels in relaxed position. Uses twin cylinders with 68" stroke and 8,000 lb. capacity at 150 psi shop air pressure.

POWER CYLINDER: To use minimum 8-1/2" plunger diameter cylinder of full-hydraulic

design featuring wiper seal, pre-energized packing seal, easily removable bearings and plungers. "I" beam equalizer system will keep movement even and automatic lock latches are standard equipment.

SUPERSTRUCTURE: The lift provides four (4) offset swivel arms on low profile superstructure and an adapter pad height of 4" above the floor.

Each arm provides a sliding sleeve and adapter assembly that can be reversed. The adapter assembly is multi-position and has a rated capacity of 2,000 lbs.

CONTROLS: An A.S.M.E. fluid storage tank with one (1) 1/2" air control (locking), an air valve muffler and one (1) 1-1/4" oil control valve are included.

GLOBE VERSATILITY

The twin-post lift with its clear center and adjustable sleeve and adapters provides mechanics more accessibility to the vehicle, allowing faster inspection, repair and lubrication. Plus, the unobstructed floor area allows easy positioning of portable tool carts, work benches and transmission dollies.



FBH-28 Base Units

Base units are made available to accommodate alignment racks and drive-on ramps. This base unit is pictured with Hunter alignment equipment and was installed at a brand new Toyota dealership. Get in, go in-ground.

Dimensional Data

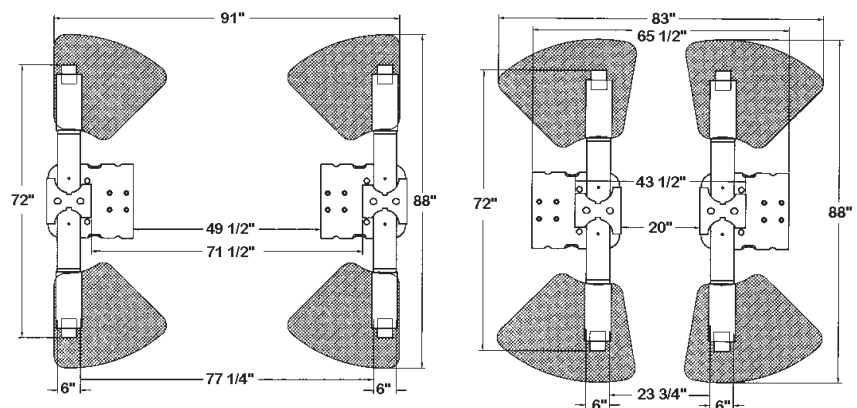

Call for more information about this lift and other quality Globe lifts

DISTRIBUTED BY:



An SVI Brand Product Line

For proper operation and to qualify for warranty service, all equipment must be installed according to detailed installation instructions, which accompany each unit.