

MANITOWOC LIFTS

INSTALLATION INSTRUCTIONS AND PARTS LIST

FORE & AFT

ELECTRIC OIL OPERATED ADJUSTABLE TRUCK LIFT

A-7FM6A

75,000 LBS CAPACITY @ 360-370 PSI

25,000 LBS FRONT PLUNGER

50,000 LBS REAR PLUNGER

Recommendations

PIPING: Use only new pipe. See that threads are perfect. Before using the pipe, hammer it to loosen all scale, spelter, and dirt, then wash the interior with kerosene. The pipe should pitch up gradually from the cylinder to the control valve with no traps or low places. Use pipe sealing compound on the male threads of all screw connections, unless your local authorities require the use of some special material. Do not use on the female thread. Verify that all pipe joints are tight, with no leaks prior to backfill and pouring of concrete. All piping must be Schedule 40 per ASTM A-53 Type E, Grade B. All fittings to be Malleable Iron, Class 300/PN 50. Do not use plastic piping, fittings, or valves.

INSTALLATION MUST BE MADE IN ACCORDANCE WITH LOCAL, STATE AND FEDERAL REGULATIONS AND IN STRICT CONFORMANCE WITH THESE INSTRUCTIONS.

USE ONLY MANITOWOC LIFTS AUTHORIZED REPLACEMENT PARTS

- Warning -

- Do not pressurize system with shipping strap in place! Do not operate until system is properly filled with oil.
- The plungers should not be rotated in the cylinders. If plungers are removed, the foolproof pin must be oriented as shown in Figure 5.2, (page 11) when they are put back into the cylinders.

- Caution -

After the plunger is installed and piping has been completed, fill the system with oil to protect the plunger from corrosion until the facility is opened. Do not raise plunger until oil has been added. If lift will not be installed within one week, fill plunger-cylinder assembly with SAE 10 hydraulic oil.

THESE INSTRUCTIONS MUST BE THOROUGHLY READ AND FOLLOWED BY INSTALLER DURING INSTALLATION, AND THEN BY THE USER THROUGHOUT THE LIFE OF THE LIFT. THESE INSTRUCTIONS MUST ALSO BE THOROUGHLY READ AND FOLLOWED BY THE AUTHORIZED SERVICE CONTRACTOR DOING SERVICE WORK ON THE LIFT TO ASSURE PROPER ASSEMBLY OR DISASSEMBLY.

FOR PROBLEMS OR QUESTIONS WITH THE INSTALLATION, CALL TOLL FREE: 800-321-8173



SVI International, Inc.
Manitowoc Lifts - An SVI Brand Product Line
(800) 321-8173 • 155 Harvestore Drive, DeKalb, IL
www.manitowoclifts.com • www.sviinternational.com

WHEEL BASE LENGTH REQUIRED IS _____ MIN. TO _____ MAX.
 "A" DIMENSION IS _____ "B" DIMENSION IS _____
 "C" DIMENSION IS _____ "D" DIMENSION IS _____

To determine the "A", "B", "C", and "D" dimensions referred to in Fig. (2), first fill in the min. & max. wheel base requirements in the space provided above.

Next look down the minimum wheel base column and find the min. wheel base required. Read across on the same line and find the max. wheel base required. When you find the max. wheel base required, read across to the right for the "A" & "B" dimensions. Directly above the max. wheel base figure you will find the "C" & "D" dimensions.

EXAMPLE: If the wheelbase of your lift is 102" to 206" then read down the left column to 102" and across to 206". At the extreme right of the 206" you will see the "A" & "B" dimensions 61" & 85". At the top of the column containing 206" you will see the "C" & "D" dimensions 153" & 169".

TRACK LENGTH															
10 Ft.	11 Ft.	12 Ft.	13 Ft.	14 Ft.	15 Ft.	16 Ft.	17 Ft.	18 Ft.	19 Ft.	20 Ft.	21 Ft.	22 Ft.			
"D" DIMENSION															
145	157	169	181	193	205	217	229	241	253	265	277	289			
"C" DIMENSION															
129	141	153	165	177	189	201	213	225	237	249	261	273			
MIN. WB	MAXIMUM WHEEL BASE													"A" DIM.	"B" DIM.
42	122	134	146	158	170	182	194	206	218	230	242	254	266	---	25
48	128	140	152	164	176	188	200	212	224	236	248	260	272	7	31
54	134	146	158	170	182	194	206	218	230	242	254	266	278	13	37
60	140	152	164	176	188	200	212	224	236	248	260	272	284	19	43
66	146	158	170	182	194	206	218	230	242	254	266	278	290	25	49
72	152	164	176	188	200	212	224	236	248	260	272	284	296	31	55
78	158	170	182	194	206	218	230	242	254	266	278	290	302	37	61
84	164	176	188	200	212	224	236	248	260	272	284	296	308	43	67
90	170	182	194	206	218	230	242	254	266	278	290	302		49	73
96	176	188	200	212	224	236	248	260	272	284	296	308		55	79
102	182	194	206	218	230	242	254	266	278	290	302			61	85
108	188	200	212	224	236	248	260	272	284	296	308			67	91
114	194	206	218	230	242	254	266	278	290	302				73	97
120	200	212	224	236	248	260	272	284	296	308				79	103
126	206	218	230	242	254	266	278	290	302					85	109
132	212	224	236	248	260	272	284	296	308					91	115
138	218	230	242	254	266	278	290	302						97	121
144	224	236	248	260	272	284	296	308						103	127
150	230	242	254	266	278	290	302							109	133
156	236	248	260	272	284	296	308		Dimensions blocked in heavy indicate standard wheel base (All Dimensions Are In Inches)				115	139	
162	242	254	266	278	290	302		121					145		
168	248	260	272	284	296	308		127					151		
174	254	266	278	290	302									133	157
180	260	272	284	296	308									139	163

GENERAL INFORMATION

1. MANITOWOC LIFTS products are designed to give many years of trouble free operation if installed correctly and given proper care.
 2. The remote lock legs are shipped disassembled from the plunger and cylinder assemblies. This reduces the possibility of shipping damage to these items.
 3. This lift operates on the full hydraulic principle which means that the load and lifting assembly are at all times supported on a continuous column of oil which extends from the cylinder to the oil control valve.
 4. MANITOWOC LIFTS will not assume any responsibility or liability, financial, legal, or otherwise, in connection with the installation of its lifts which goes beyond the stated limitations of the standard instruction sheet or drawings currently applying, at the date of shipment, to individual models. Under no circumstances should any safety device be removed or defeated.
 5. In the event MANITOWOC LIFTS Representatives consult with contractors, owners, or their employees regarding location of lift or any other matters such as layout, head room, or floor planning, this consultation shall not be taken as a representation of accuracy, and MANITOWOC LIFTS will not assume any liability or responsibility in any manner whatsoever. It is RECOMMENDED that an architect or engineer be consulted to determine soil conditions.
- LOCATION OF LIFT. Proper location of the lift is essential

to insure efficient usage and operation. A careful study should be made of the area. Fig. 2 illustrates the minimum requirements for positioning of this lift. When two or more lifts are installed adjacent to one another, they should be set with a recommended minimum distance of 14 ft. between center lines of lifts.

CONSIDER:

DIRECTION OF TRAFFIC flow.

APPROACH SPACE to allow adequate maneuverability of the vehicle on to lift.

WORKING AREA required around vehicle.

FLOOR LEVEL. Lift to be installed on level floor and floor drains are recommended.

HEADROOM above lift. Provide ceiling clearance for your highest vehicle when the lift is raised. The lifting point of adapters above the floor level is 65 inches for front plunger and 67 inches for rear plunger.

LOCATION OF THE LIFT CONTROL VALVES per Fig. 3 (Page 8), Fig. 13 (Page 20), and Fig. 15 (Page 21). Controls should be located to give the operator a clear unobstructed view of the front and rear pistons of the lift.

INSTALLATION INSTRUCTIONS

1. LOCATION. Determine lift location and make certain that proper working space and clearance is available as outlined in previous section "Location of Lift".
2. EXCAVATING. Figure 2 illustrates dimensions for all excavations.
3. INSPECT CYLINDERS FOR SHIPPING DAMAGE and check drain plug for tightness before cylinder assembly is installed.
4. CONSTRUCTION OF FRONT TRENCH WALLS.
 - A. Assemble track, extension box and control box as shown in Figure 13 or Figures 15 & 16 for Optional Power Carriage.
 - B. Place wooden spacers in the track to maintain 17-13/16"±1/8" between the sides of the track. This 17-13/16"±1/8" dimension must be within tolerance specified for the full length of the track as shown in Figure 3.
 - C. Attach two 4" x 4" timbers across the top of the track and one across the control box as shown in Fig. 3. Place into correct position over excavation. 1/8" holes are provided in front and rear of track as reference points for the fore-and-aft center line. Shim under each end of the timber so that the top flange surface of the track, the cover of the extension box and control box are flush and level with the finished floor.
 - D. Construct wood forms for pouring concrete walls. In most cases it will be necessary to construct a wooden form having an inner and outer wall. Thickness of wall should be 8 inches (6 inches minimum). Brace the track during pouring and curing. Be sure to maintain

the 17-13/16"±1/8" between trench walls. Provide for an opening in the area of the extension box, also an opening 27" down from floor level on the rear wall to receive the 4" dia. conduit for the oil line and a 4" PVC drain pipe from the rear box. This lift is installed with a remote control lock leg, so an air line will also go thru the 4" dia. conduit.

5. REAR BOX INSTALLATION

- A. Pour a six (6) inch thick concrete pad at the bottom of the rear excavation for the cylinders to rest on. Maintain 113 inches from finished floor to top of concrete pad. See Figure 5.2.
- B. Attach the lock leg to the dual cylinder assembly and then assemble the dual cylinder assembly to the rear box.
- C. Attach two 4" x 4" timbers across top surface of rear box. See Figure 4.
- D. Lower rear box with dual cylinder and lock leg assembled into excavation. Make sure that pipe connections on cylinders are positioned towards the front.
- E. Shim under each end of the timbers so that the top surface of the box is level with the finished floor line and square with the axis of the front track. Locate the box correctly from the front track. 1/8 inch dia. holes are provided in the top flange of the end angles to serve as reference points for the center line of the rear box.
- F. After rear box is leveled, squared and blocked into position, level top edge of plunger by means of the leveling bolts. "W" and secure with hex nuts "V". See Figure 11.

- G. Install oil line (1-1/4" pipe) and conduit pipe between rear cylinder inlet coupling and front trench. Run air line (1/8" pipe) between rear box & front trench as shown in Fig. 5.2. Install 4" PVC drain with 1/2" x 1' pitch.
- H. Imbed the base of the cylinder and the lock leg tube in concrete and at least 6" thick around lock leg tube per Figure 5.2.
- J. Backfill & compact with clean sand around rear cylinder. Do not use cinders or other corrosive materials.
- K. Attach wheel spotters to rear box as shown in Fig. 11.
6. POURING OF CONCRETE
- A. Pour side walls and lower pad, making sure that surface of pad is at least 94" from finished floor level.
- B. Rear box and cylinder, pour concrete around the top of the rear cylinder and rear box. See Figure 5.2. Concrete level inside of box should come up to the top of the leveling plate welded to the cylinder bolt ring. Do not allow concrete to come above the top of the leveling plate or above the top of the outer post assembly. This is especially important when installing a lift with a remote control lock leg since the operating mechanism for this mounts on the top flange of the outer post assembly.
7. OIL LINES. Connect supply and return lines from electric oil unit to control box as shown in Figure 5.1. For units with the power carriage option, see Figure 14 for additional oil line requirements.
8. AIR LINES. Run air tubing from air valve to control box walls as shown in Fig. 19 (Page 13). Connect air line from compressed air source to control box as shown in Fig. 5.1. Water traps and air filters are recommended. Maximum air pressure not to exceed 125 P.S.I.
9. EXTENSION BOX. Pour concrete around and beneath extension box and control box. See Fig. 5.1, Section A-A.
10. BACKFILL. Complete backfill around front trench wall, extension box, and control box.
11. FINAL POURING OF CONCRETE. All remaining pouring of concrete may now be completed. When floor is poured, be sure that concrete is worked well under the lower flange of the track, for maximum support. Also taper concrete up to the 5/16" square rod on top of track. See Figure 5.1, Section C-C. Form rear wheel wells as shown in Figure 5.2, Section F-F.
12. INSTALLATION OF FRONT CYLINDER AND REMOTE CONTROL LOCK LEG TO CARRIAGE.
- A. Install carriage in front track through openings in the top flanges.
- B. Lower cylinder onto carriage, inlet facing front.
CAUTION: Be sure to use cylinder T13944-02 here.
- C. Level top edge of plunger by means of leveling screws "L". After leveling, shim between cylinder and carriage. Secure cylinder with hex nuts "H". See Fig. 8.
- D. Fasten outer post asm. to carriage. See Figure 8.
- E. Install remote lock leg mechanism on carriage as shown in Figure 10. For assembly procedure, See Figure 1. Insert one (1) hex head bolt 5/16"-18 x 1-3/4" lg. (Item "A"), 5/16" washer and spacer (L) at pivot point of jaws and tighten. Insert two (2) hex head bolts 1/4"-20 x 1/2" lg. (Item "B"), 1/4" flat washer and 1/4" lock washers thru slot "G" into carriage. Before tightening these bolts attach spring to linkage at point "J". Spring tension should hold jaws against O.D. of lock leg. Adjust mounting bracket "H" so that center line of air cylinder projects thru center line of lock leg and pivot. Tighten bolts (Item "B"). Loosen set screw "E" and screw air cylinder shaft "D" in or out of block "F" until both jaws barely contact O.D. of lock leg. Tighten set screw "E". Open jaws manually to see if jaws clear stop ring on lock leg. The clearance should be 3/16" on both sides. Connect flexible air hose as shown in Figure 10.
- F. Install flexible oil hose. See Figure 5.1.
- G. Install rear sprocket assembly. See Figure 8.
- H. Install front sprocket shaft and ratchet mechanism. See Figure 13.
- I. Install chain around front and rear sprockets and attach chain to carriage. See Figure 8. Adjust chain so that sag is no greater than 1".
13. COMPLETE PIPING. Finish piping as shown in Figure 5.1. For left hand installation see Figure 6. For power carriage option install additional piping as shown in Figure 14. Avoid contaminating inside of piping with excessive amounts of pipe dope, teflon tape, dirt, etc.
14. WEIGHT ALL PLUNGERS. Ballast should be provided for all plungers. This may be accomplished by filling the hollow of the plungers with a mixture of clean oil and sand, (no foundry sand), is recommended. Care should be taken not to let sand into the packing area by providing a funnel of some type.
15. FINAL ASSEMBLY ITEMS.
- A. Place trench cover plates (GG) and (HH) over studs in carriage. Secure covers with hardware shown in Figure 8. Make sure that washer (J) does not come in contact with the covers and that the covers are free to move between guide bars on the track. Connect the remaining covers.
- B. Bolt on front pickup base to plunger. Insert pickup slides in pickup base. Install lock leg. See Figure 8.
- C. Manually move carriage completely in both directions with ratchet handle. Check for freedom of movement and that binding at any point does not occur.
- D. Bolt rear axle support beam to rear plunger. Fasten lock leg to support beam. Mount axle supports on support beam. See Figure 11.
- E. Install mechanism on leveling plate as shown in Figure 12. For assembly procedure, See Figure 1. Insert one (1) hex nut 5/16"-18 (Item "A"), 5/16" washer, and spacer (L) at pivot point of jaws and tighten. Insert two (2) hex head bolts 3/8"-16 x 1/2" lg. (Item "B"), 3/8" flat washers, and 3/8" lockwashers thru slot "G" into leveling plate, before tightening these bolts attach spring to linkage at point "J". Spring tension should hold jaws against O.D. of lock leg. Adjust mounting bracket "H" so that center line of air cylinder projects thru center line of lock leg and pivot. Tighten bolts (Item "B"), loosen set screw "E" and screw air cylinder

shaft "D" in or out of block "F" until both jaws barely contact O.D. of locking leg. Tighten set screw "E". Open jaws manually to see if jaws clear stop ring on lock leg. Connect flexible air hose and breather vent as shown in Figure 12.

F. Install Rear Doors. See Figure 11.

16. LOCATION OF POWER UNIT.

Since a substantial amount of noise can be generated by electric oil power units, care should be exercised in choosing a suitable location for installation of the unit. Pipe power unit to lift as shown in Figure 5.1. Use a 30 Amp breaker and wire per Figure 22, Page 15.

17. FILL SYSTEM WITH OIL.

The minimum oil requirement to operate this lift is 115 gallons. The actual quantity required to fill the system may increase due to the capacity of the oil reservoir used in conjunction with the lift. Use only oil which is recommended by the petroleum manufacturer for hydraulic lifts. Viscosity rating should be approximately 100-125 SSU at 100° F. Most SAE 10 oils (new) are acceptable. Avoid oils which foam under air pressure or those which may have an undesirable effect on the synthetic rubber packing of the lift cylinder. A rust inhibitive type oil is recommended. Use fresh, clean oil and avoid introducing contamination into systems during filling.

Follow the steps given below, keeping in mind that the system must be filled and bled gradually.

A. Remove the shipping strap from the top of plunger and cylinder assemblies by removing the two (2) 7/16"-14 x 1-1/2" lg. bolts and discard the shipping strap. Put the same two (2) bolts back into the same holes to hold the wiper retainer ring.

IMPORTANT. Six bolts are required to properly hold the wiper retainer ring.

B. Remove air breather from oil reservoir.

C. Loosen air vent plug (located in top cylinder casting).

D. Fill reservoir to a level within 1" of its fill opening.

E. Replace air breather.

F. Bleed air from cylinder by gradually admitting oil to cylinder by turning the oil control valve in the "up" position and holding the cylinder valve in the open position. Air will escape from air vent. When a steady stream of oil flows freely from air vent hole, close oil control valve and tighten air vent plug. Raise plunger no more than 3 ft. Close oil control valve. Check all piping joints for leaks.

G. Lower lift by turning the oil control valve to the "down" position and holding the cylinder oil control valve open.

H. Check oil level in reservoir.

Repeat bleed and refill procedure until no air escapes from air vent.

18. OPERATING INSTRUCTIONS. **IMPORTANT.**

The permanent operating instructions along with inspection and maintenance instructions furnished with this lift should be permanently and conspicuously displayed in the lift control area. Automotive lifts should be operated by trained personnel only. If you do not know how to position vehicle properly, do not guess. Get training. Start by reading the operating instruction, the booklet "Lifting It Right", and the "Automotive Lift Safety Tip Sheet", furnished with the lift. Also refer to the vehicle manufacturer's service manual for proper lift points and lifting procedures.

19. HOW TO ORDER REPLACEMENT PARTS. **IMPORTANT.**

Be sure to mention the lift model number and serial number in all correspondence dealing with service information and when ordering replacement parts. This information is on the top of the plunger & cylinder assembly.

20. **IMPORTANT.**

Underground corrosion takes place in varying degrees throughout the United States and may cause a major problem with lift equipment. To protect underground lift components, MANITOWOC LIFTS recommends that an analysis of local soil conditions be obtained, and that a knowledgeable source be consulted relative to the implementation of an adequate corrosion control system. See MANITOWOC LIFTS Warranty.

Remote Control Lock Leg

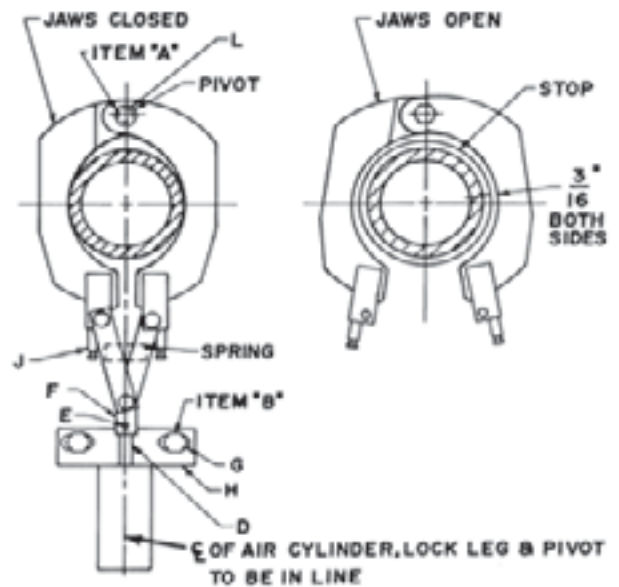

K90201

Fig. 1

INSTALLATION INSTRUCTIONS FOR ENVIROKOTE COATED LIFT COMPONENTS

The excavation must be free of any material that may damage the Envirokote Coating on the Lift Cylinder. Equipment for installing these components must be adequate to prevent damage to the coating from dragging or dropping. Similar care must be given to the coated piping. Backfill must consist of clean sand or other suitable fill that is free of organic material, rocks, debris, and other sharp objects. The backfill must be deposited carefully and completely around the buried Lift Cylinder and Piping. When tamping backfill, care must be taken to avoid damaging the Envirokote Coating.

All underground piping, joints, fittings, and tie-ins to the Envirokote Coated Lift Cylinders must be coated with a material compatible with the Envirokote Coating. Make all piping connections in accordance with local, state, or Federal regulations. Suitable Dielectric Unions must be used to isolate protected underground piping from unprotected above ground piping. All bracing and/or supports for unprotected above ground piping must be attached above the Dielectric Unions.

TYPICAL INSTALLATION DETAIL

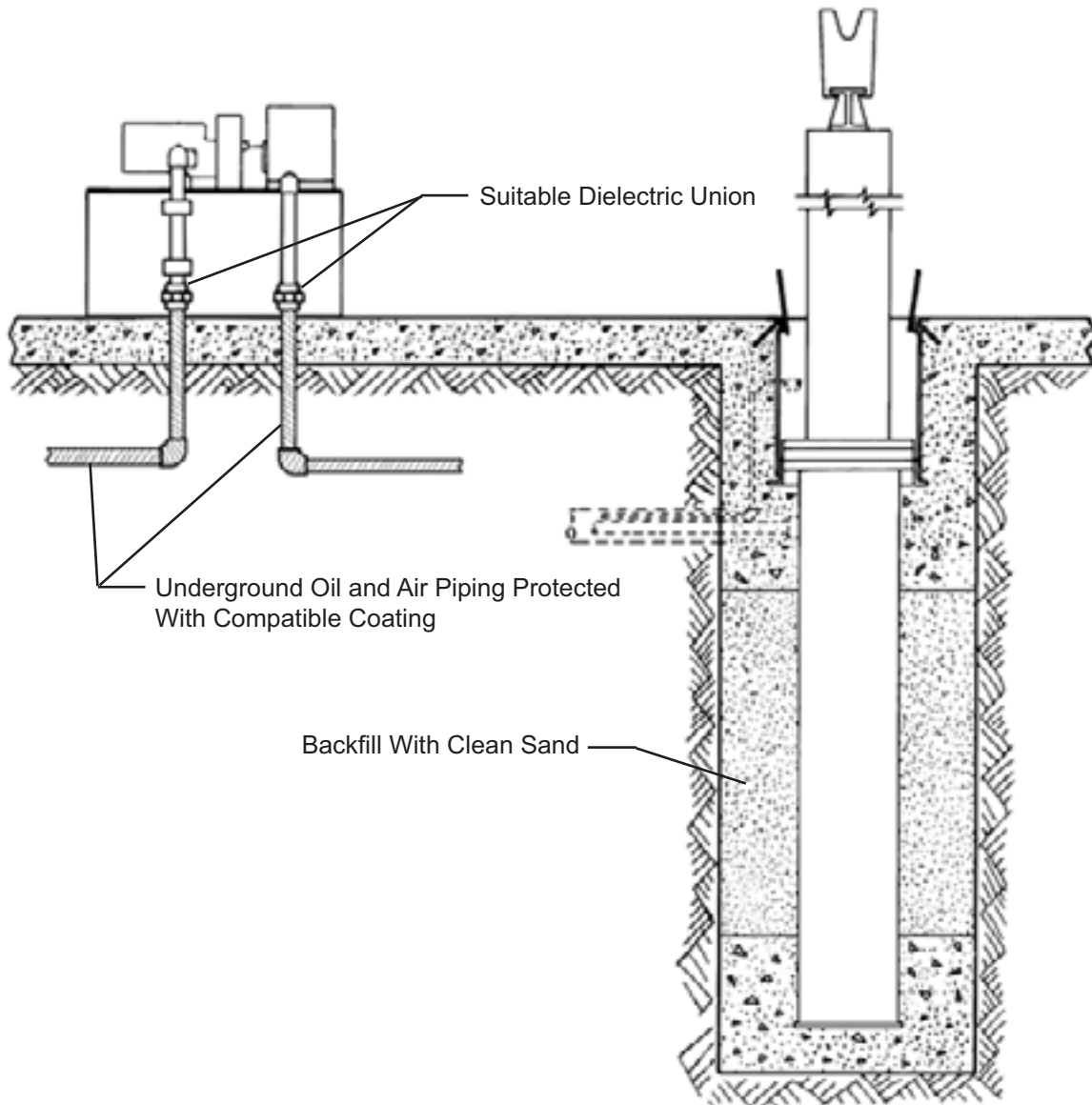

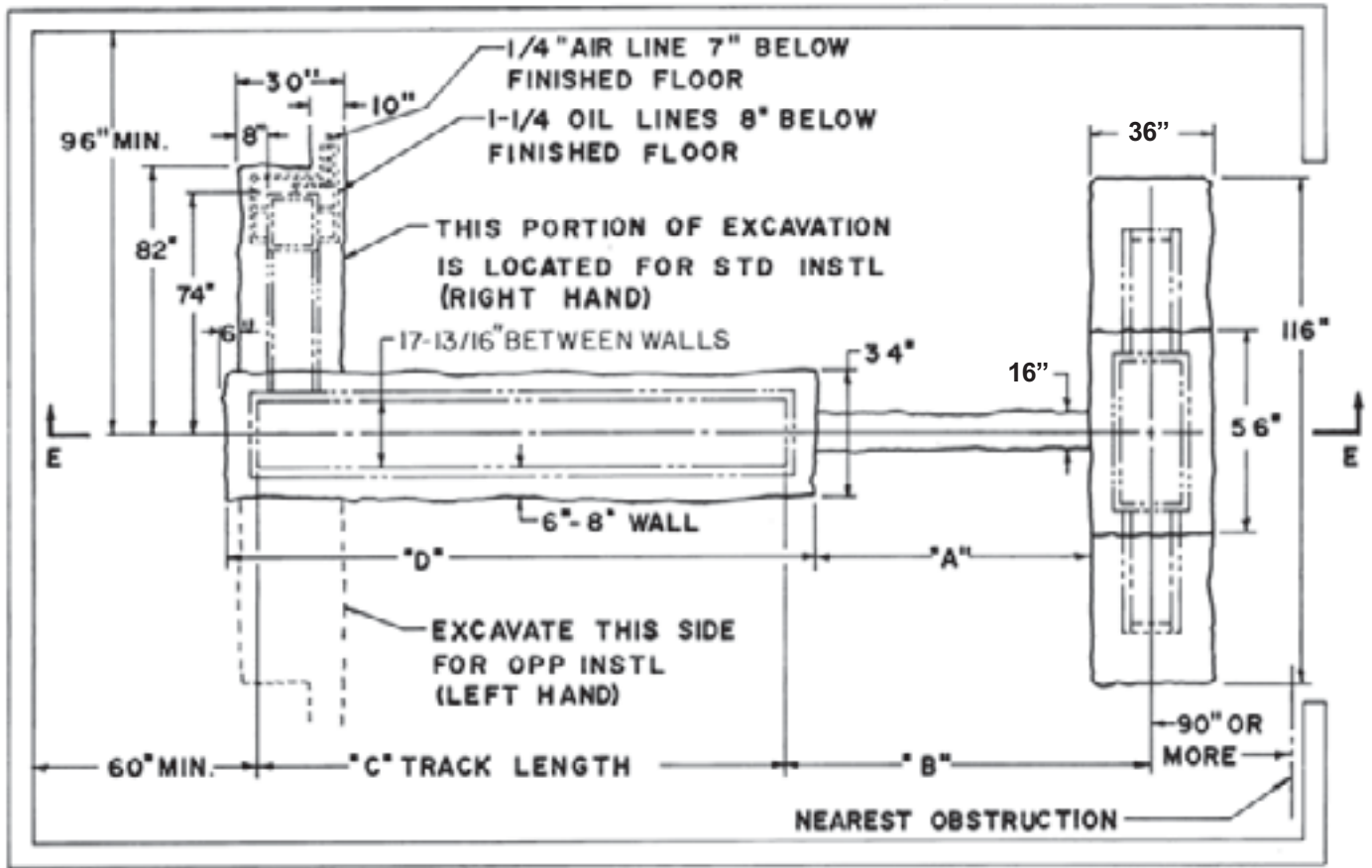

Note:

All Excavation Dimensions are based on 8" Thick Walls (6" Min.) and 6" Thick Floor (4" Min.)

Caution:

Consult an architect or engineer if your soil compression factor is less than 4,000 P.S.F.

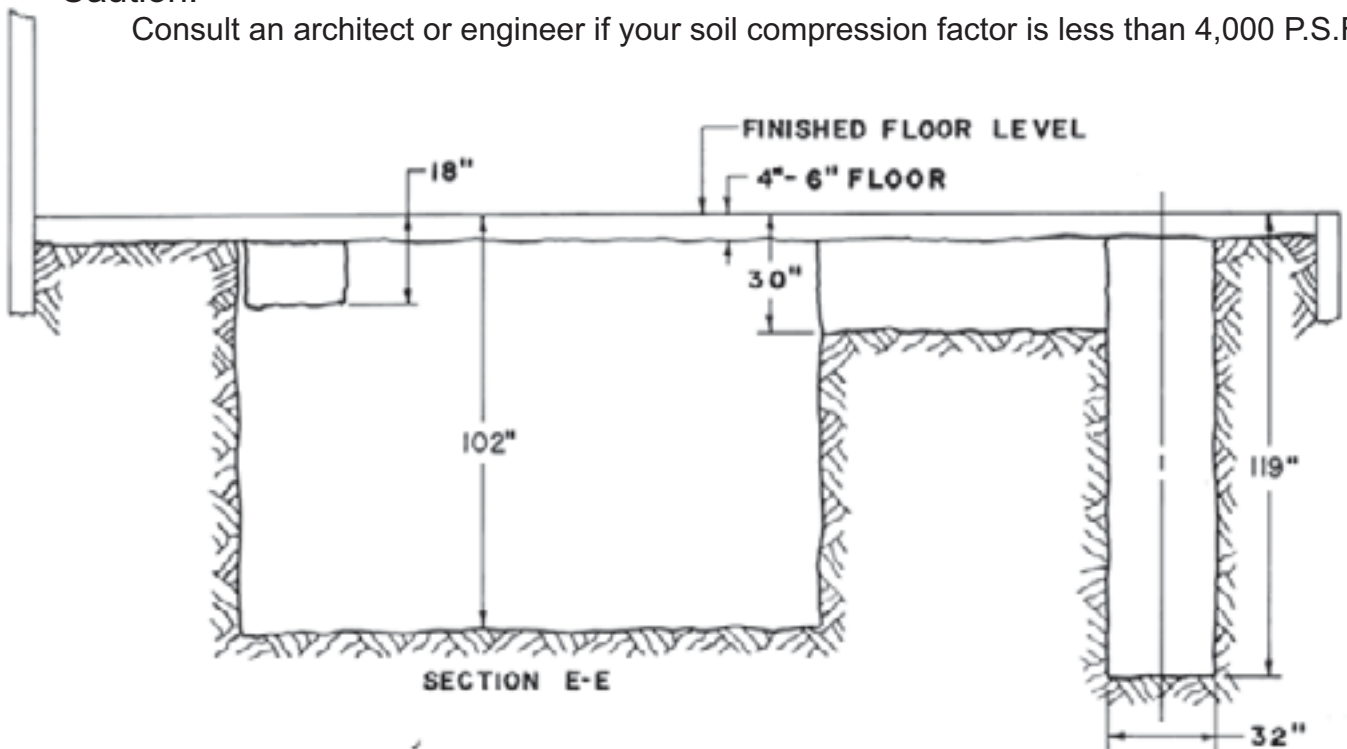

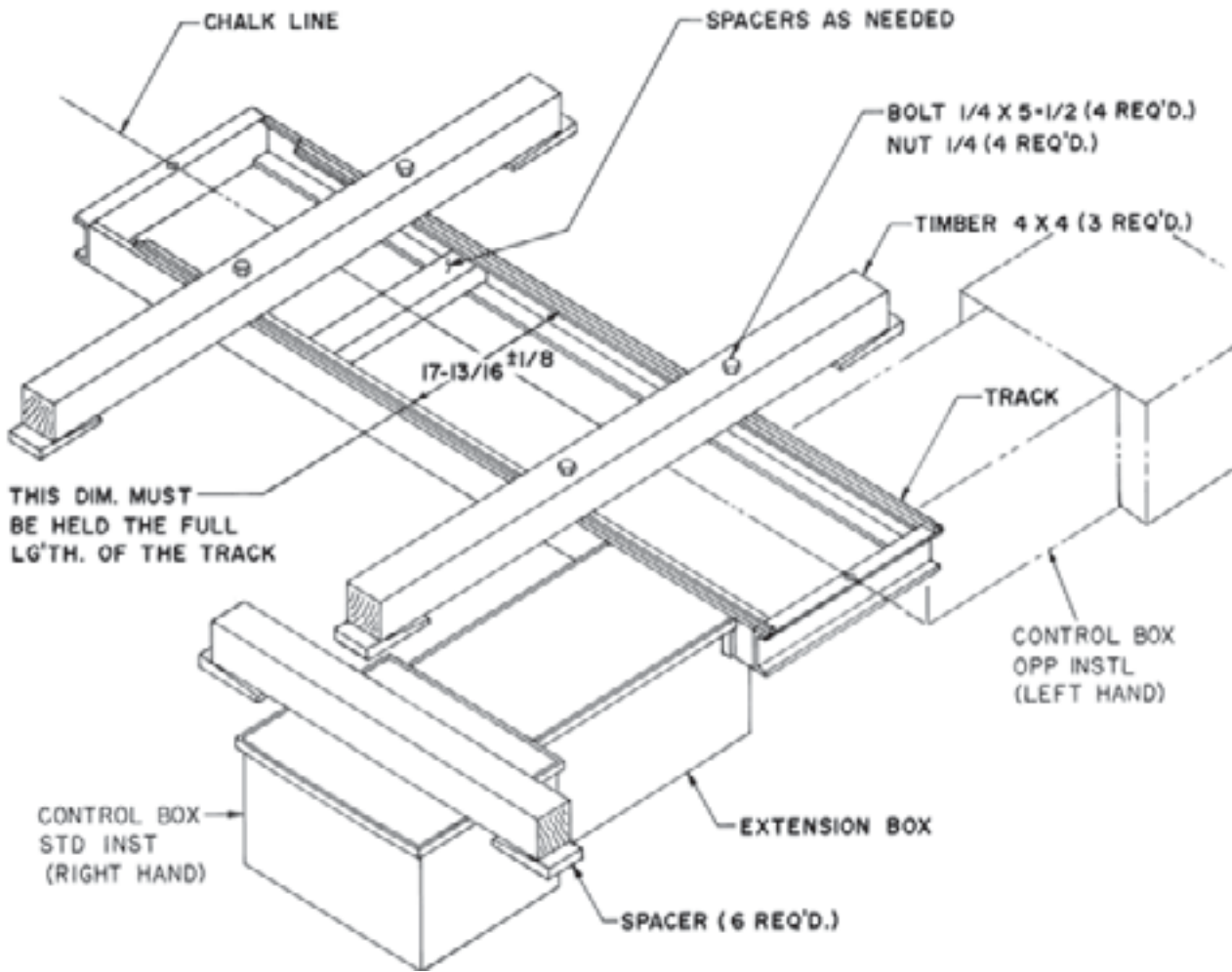

Fig. 3

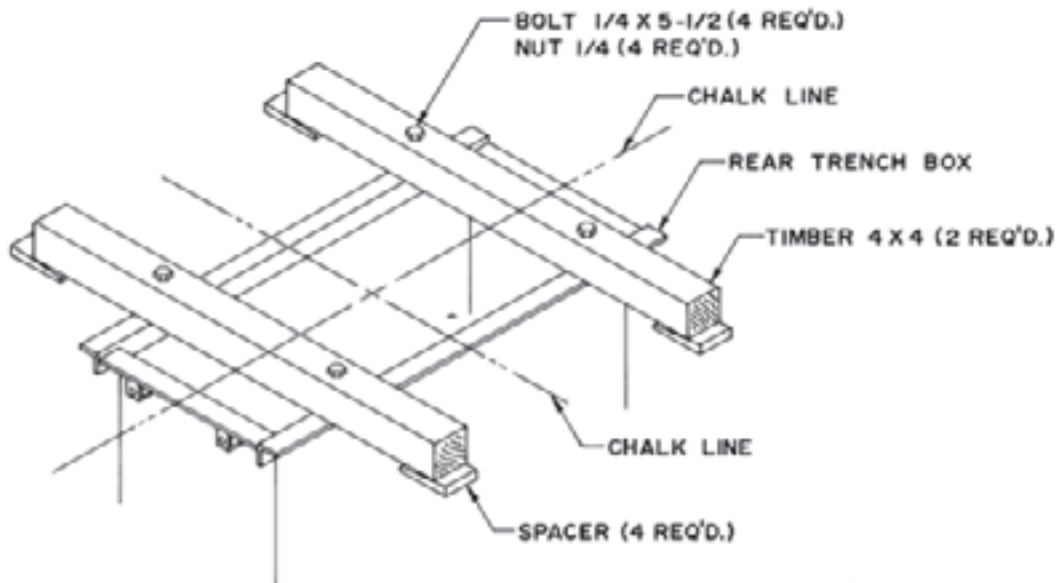
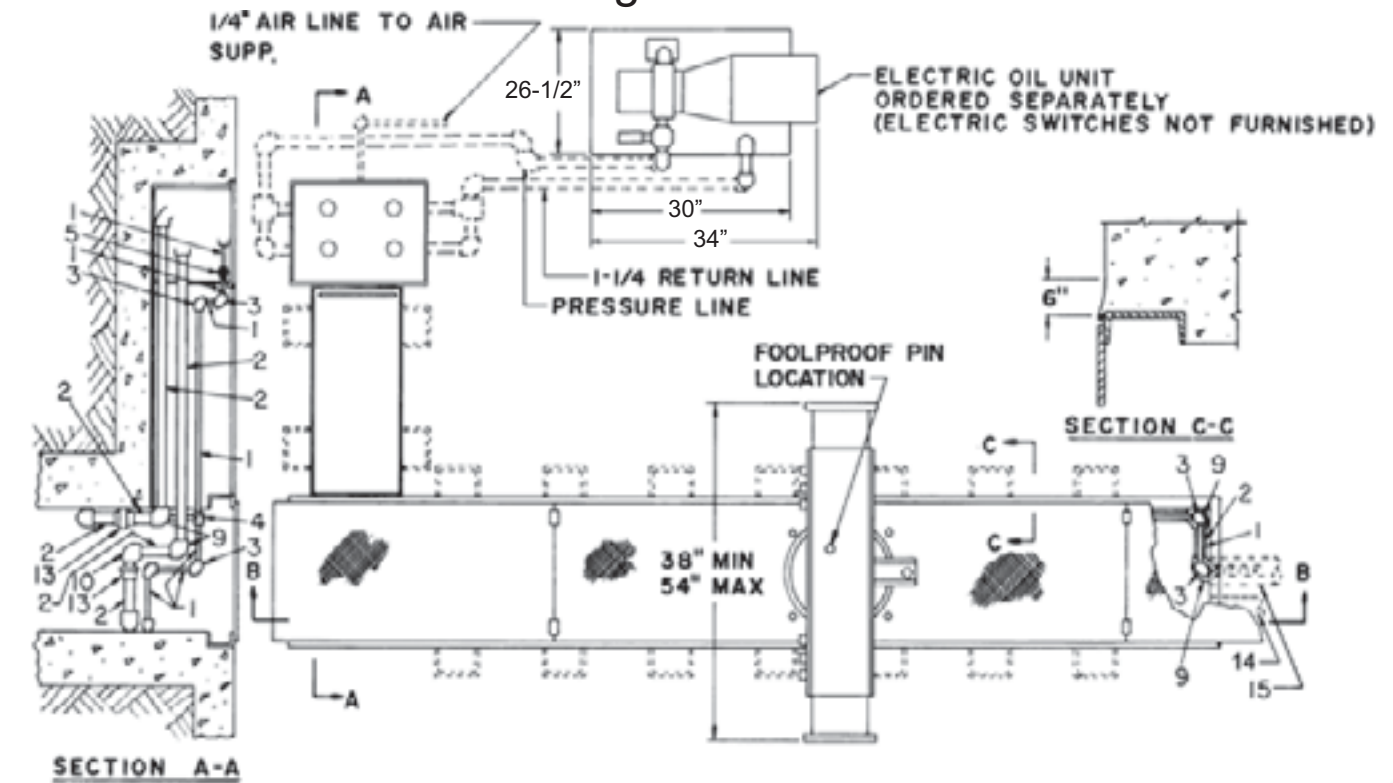

Fig. 4

Standard Right Hand Installation



Code No.	No. Req.	Symbol No.	Description
A	1	K90640-01	Hose
B	1	K90640-02	Hose
B	1	K90640-02	Hose (21 Ft. & 22 Ft. Track Only)
C	1	K90150-01	Hose, Air Front

See Fig. #14 and Fig. #16 for piping requirements of power carriage option.

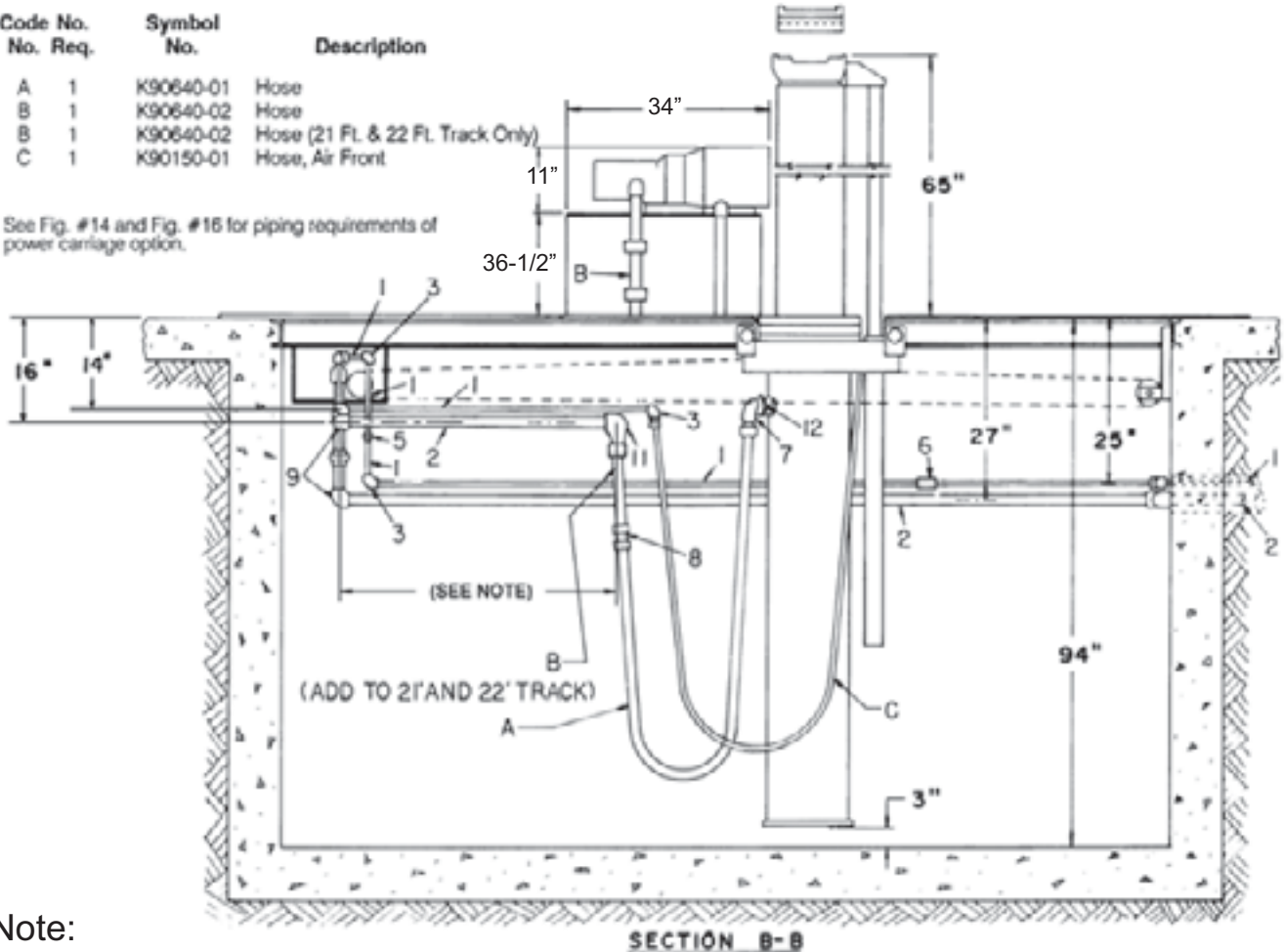

Note:
Extend solid piping to midpoint of total carriage travel.

Fig. 5.1

Opposite Standard Left Hand Installation

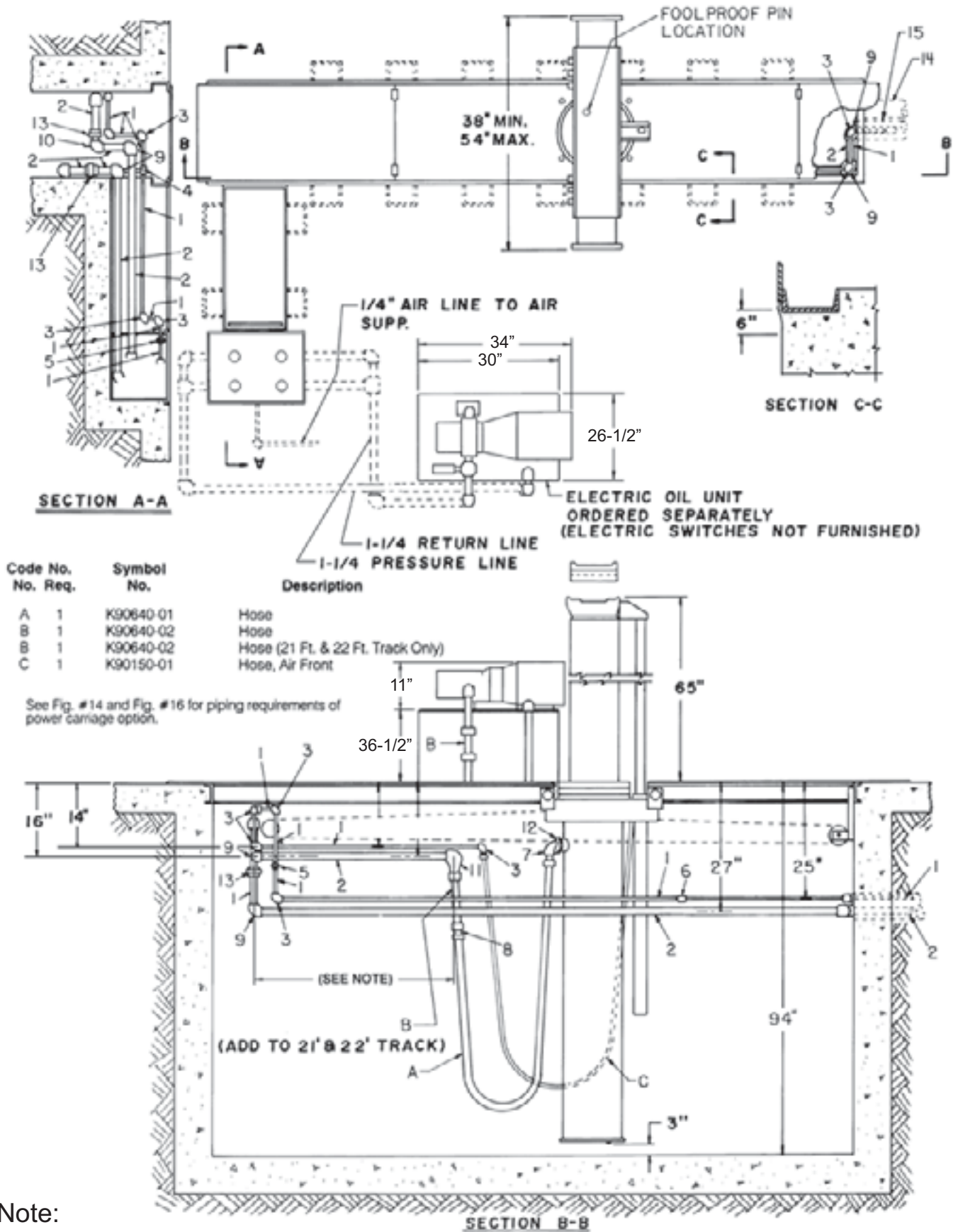

Note:
Extend solid piping to midpoint of total carriage travel.

Fig. 6

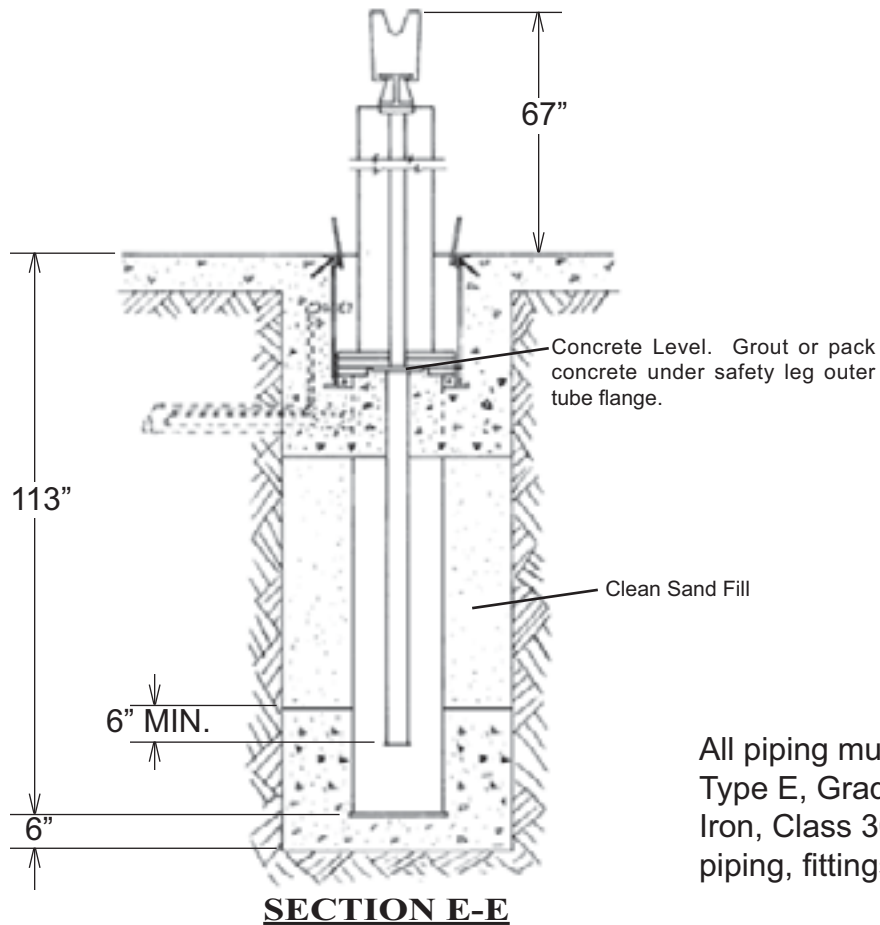
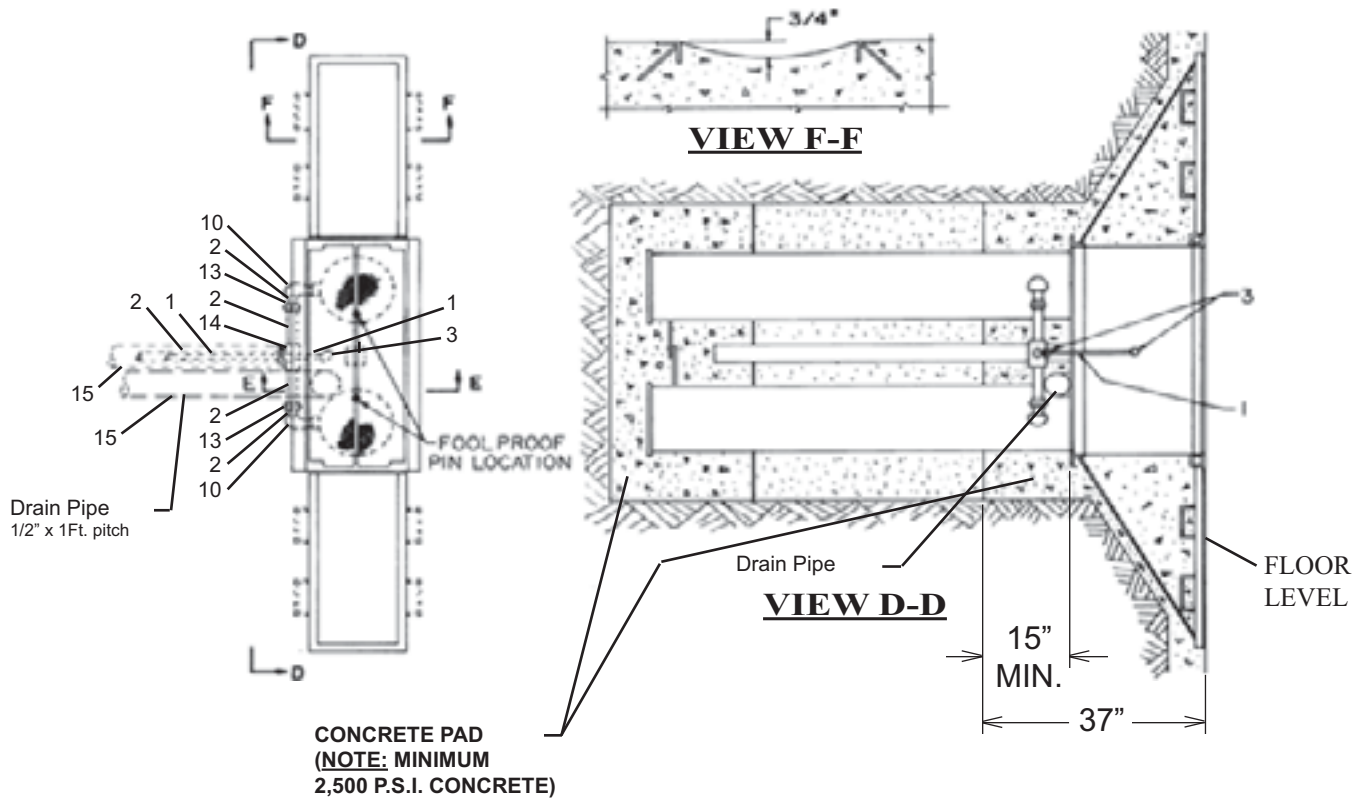

Pipe/Fitting Schedule

ITEMS FURNISHED BY INSTALLER

Code	No.	Description
	1	Pipe, 1/8" Dia. Stl.
	2	Pipe, 1-1/4" Dia. Stl.
	3	Elbow, 1/8" x 90°
	4	Tee, 1/8" x 1/8" x 1/8"
	5	Union, 1/8"
	6	Coupling, 1/8"
	7	Street Elbow, 1" x 90°
	8	Coupling, 1" (21 Ft. and 22 Ft., Track Only)
	9	Elbow, 1-1/4" x 90°
	10	Street Elbow, 1-1/4" x 90°
	11	Reducing Street Elbow, 1-1/4" To 1"
	12	Reducer Bushing, 1-1/4" To 1"
	13	Union, 1-1/4"
	14	Tee, 1-1/4" x 1-1/4" x 1-1/4"
	15	PVC Pipe, 4" Dia. Sch. 40, DWV

All piping must be Schedule 40 per ASTM A-53 Type E, Grade B. All fittings to be Malleable Iron, Class 300/PN 50. Do not use plastic piping, fittings, or valves.

Fig. 5.2

Control Box Assembly

Note:

Cut tubing K95123 into two pieces,
28 inches and 20 inches.

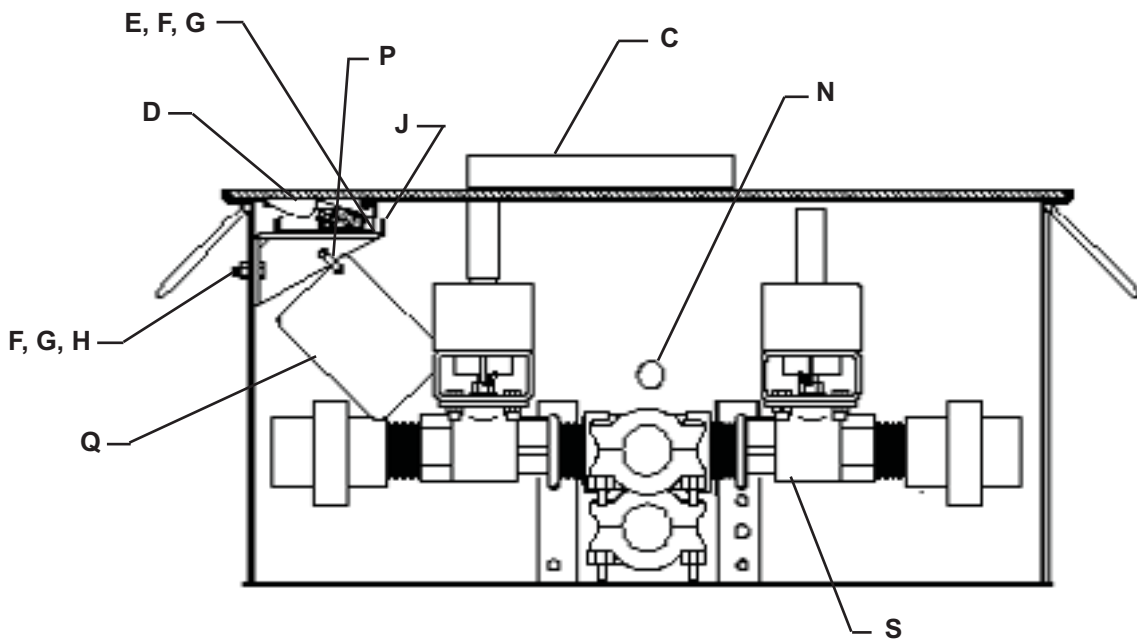
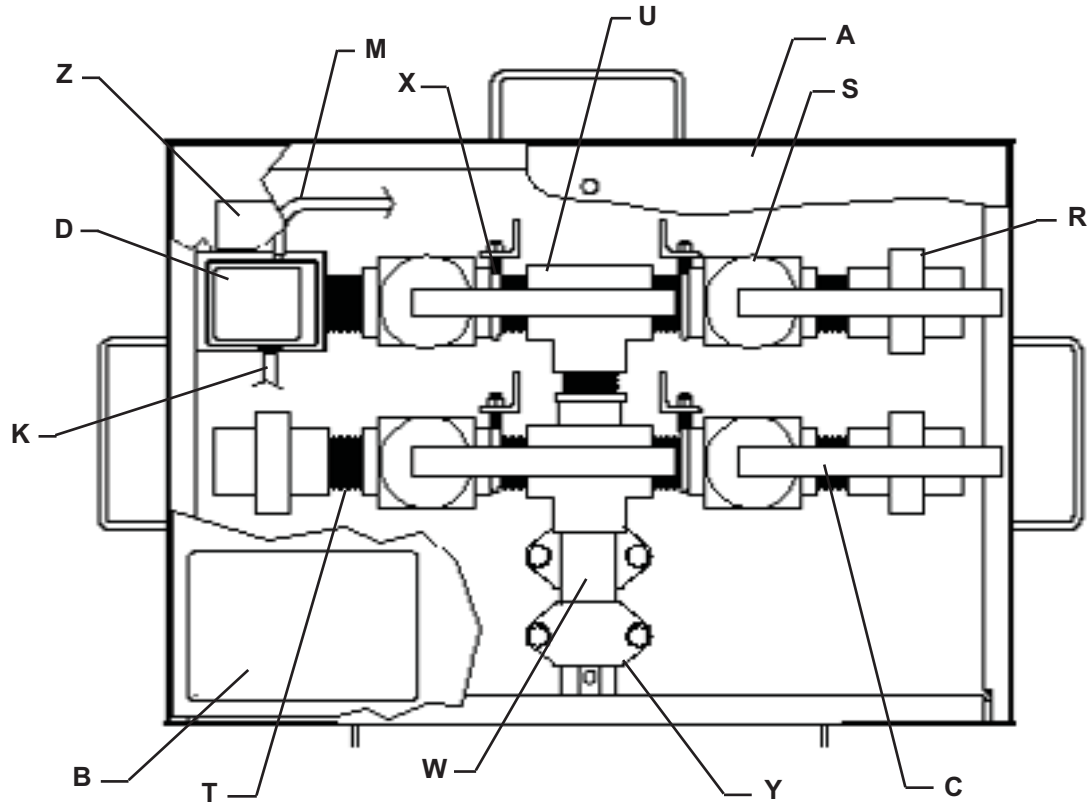

Control Box Assembly

When ordering replacement parts, always mention lift model number and serial number.

Code No.				Code No.			
No.	Req.	Symbol No.	Description	No.	Req.	Symbol No.	Description
A	1	R19067	Control Box Cover	Q	1	B-100-106	Nameplate Blank
B	1	N23122	Operation Plate	R	4	K12176	Union
C	4	N23123	Oil Valve Handle	S	4	R19066	Oil Valve Assembly
D	1	R19032	Air Valve Assembly	T	9	R11494-51	1-1/4" Close Nipple
E	1	K05287	1/4"-20UNC x 1/2" Bolt	U	2	Q10840-06	1-1/4" Tee
F	3	B-104-26	1/4" Lockwasher	V	1	K03608-24	1-1/4" x 45° Elbow
G	11	K01941	1/4"-20UNC Hex Nut	W	4	K95120	Grooved Pipe Nipple
H	2	B-101-04	1/4"-20UNC x 3/4" Bolt	X	4	K58558	1/4"-20UNC U-Bolt
J	1	N23058	Air Valve Bracket	Y	2	K95125	Grooved Pipe Coupling
K	1	K95123	Push-On Air Hose (Cut to 28")	Z	1	A-529-46	Safety Lock Release Decal
M	1	K95123	Push-On Air Hose (Cut to 20")		1	T19045	Complete Control Box Assembly
N	2	A-529-16	Push-On Coupling				
P	1	A-501-30	Wire Tie				

See Pages 9 and 10 For Control Box Location

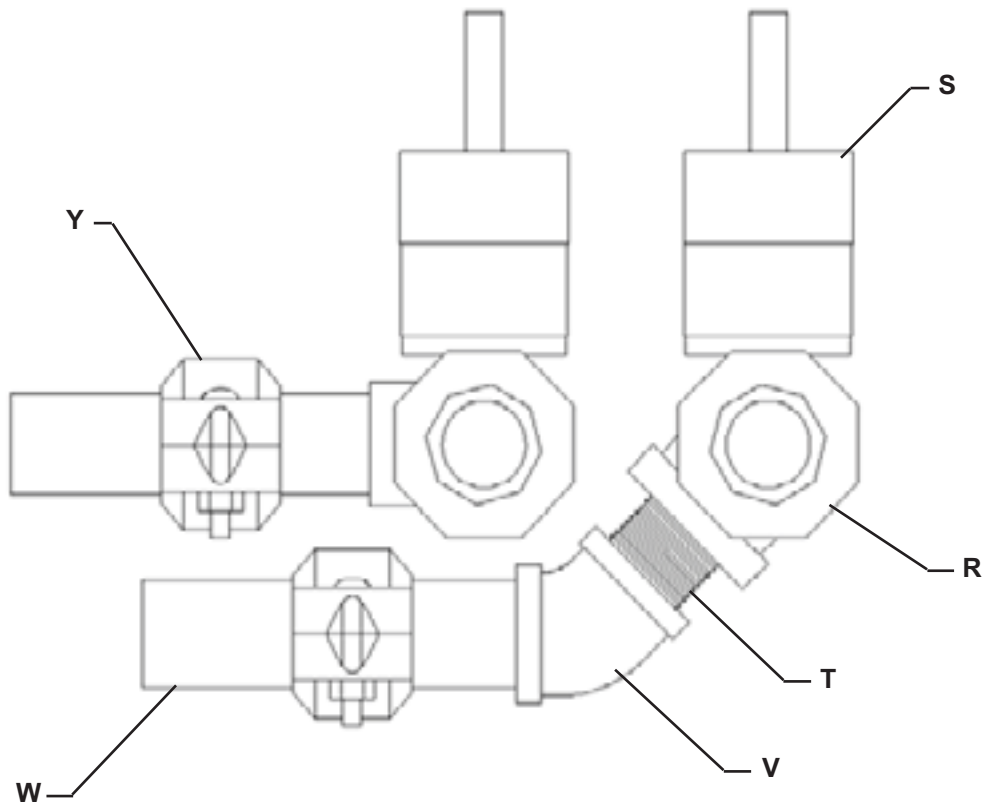

Note:

If servicing lift refer to item Q,
Nameplate Blank, for lift information.

Oil Control Valve

When ordering replacement parts, always mention lift model number and serial number.

Code No.	No. Req.	Symbol No.	Description
1	1	N23059-01 R19066	Oil Valve Complete Valve Assembly

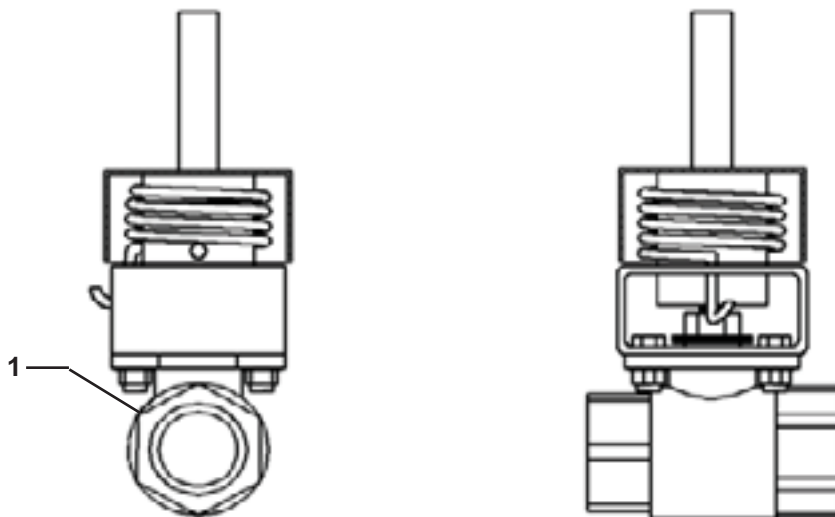

Grooved Pipe Coupling Detail

Note:

Avoid wrench marking on the grooved end of the nipple, K95120.

Apply a thin coating of lubricant to the outside and sealing lips on the gasket of the grooved pipe coupling before assembling coupling, K95125.

Coupling nuts must be tightened alternating and evenly to 30-40 Ft. Lbs. bolt torque.

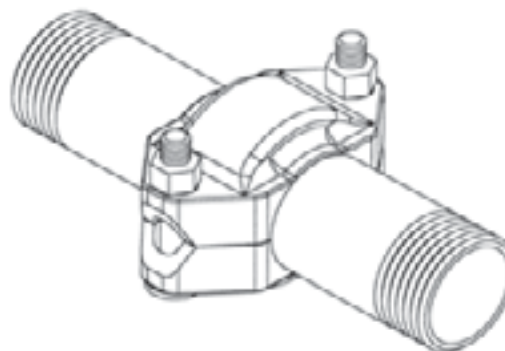
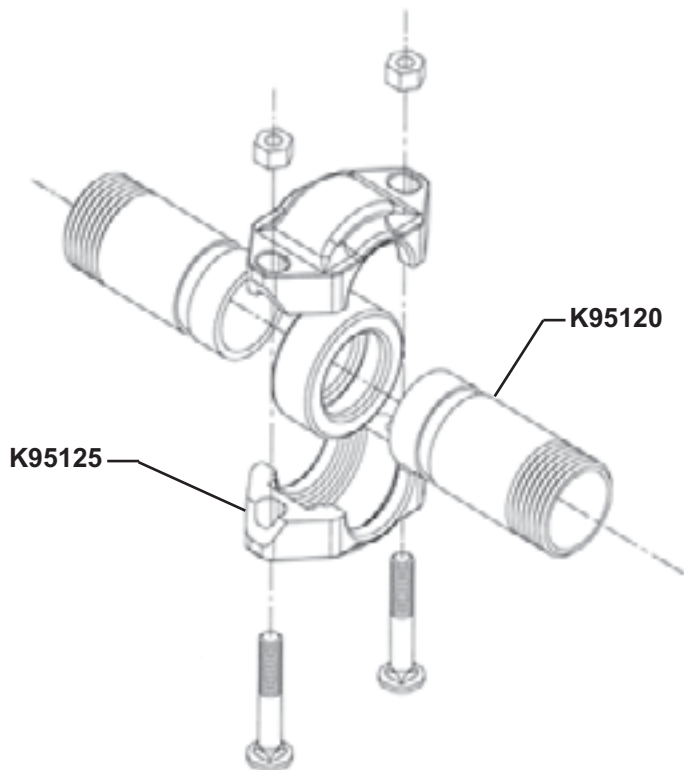

Fig. 21

Exploded

Assembled

E05 Electric Oil Power Unit

When ordering replacement parts, always mention lift model number and serial number.

Code No.	No. Req.	Symbol No.	Description
A	1	T19034-01	Tank
B	1	R19040-01	Tank Cover
C	8	K60521-24	#14 x 5/8" Hex Hd. Screw
D	1	R19041	Pump & Motor Assembly (Includes E thru M)
E	1	K95138	Motor 10 HP 3ph
F	1	K95140	Vane Pump
G	1	K95141	Pump to Motor Adapter
H	1	K95142	Motor Coupling
J	1	K95143	Pump Coupling
K	1	K95144	Coupling Insert
L	1	K95145	Inlet Flange
M	1	K95146	Outlet Flange
N	4	K03239	5/16"-18 x 1-1/2" Hex Hd. Scr.
O	4	B-103-08	5/16" Flat Washer
P	4	B104-29	5/16" Lockwasher
Q	2	K47984	2" x 90° Street Elbow

Code No.	No. Req.	Symbol No.	Description
R	1	K95131	Suction Flange
S	1	N23069-01	Suction Element
T	1	K89036	Air Breather (Twist Type)
U	1	N20383	1-1/4" Close Nipple
V	2	R11494-51	1-1/4" Pipe Cross
W	1	Q10838-06	1-1/4" Pipe Plug
X	2	K02309C02	Relief Valve Assembly
Y	1	N23070	Relief Pipe
Z	1	K95132	Tank Flange
AA	1	N21737-02	Return Pipe
BB	1	K95133	Protective Closure
CC	1	K78953-23	2" Pipe Plug
DD	1	K02286	Nameplate
EE	1	K89053	Caution Decal
FF	1	K95022	Complete Electric Oil Unit
		T19035-01	

MOTOR WIRING DIAGRAM IS LOCATED INSIDE COVER ON MOTOR JUNCTION BOX. CONTACT A LICENSED ELECTRICIAN FOR PROPER MOTOR WIRING.

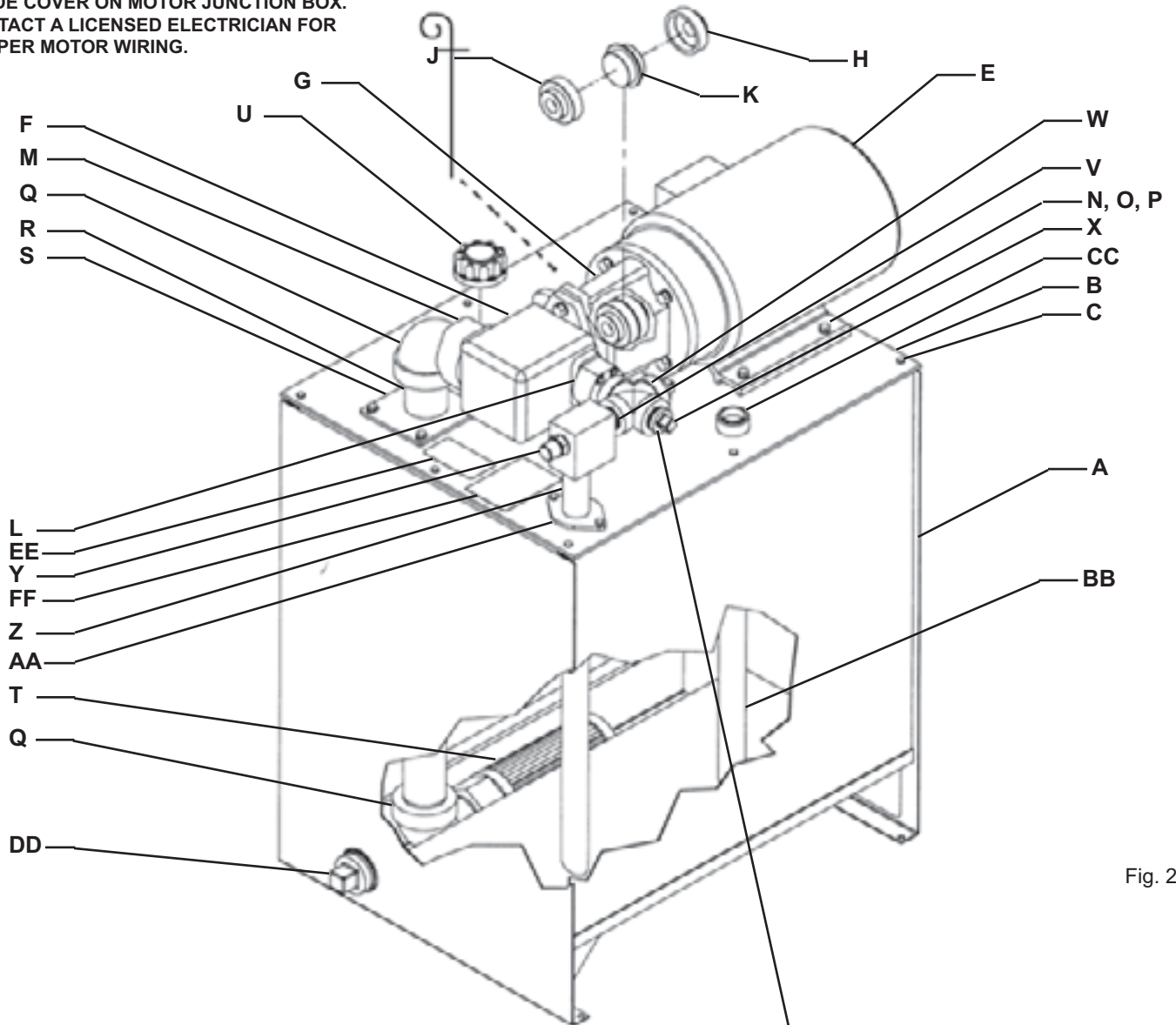
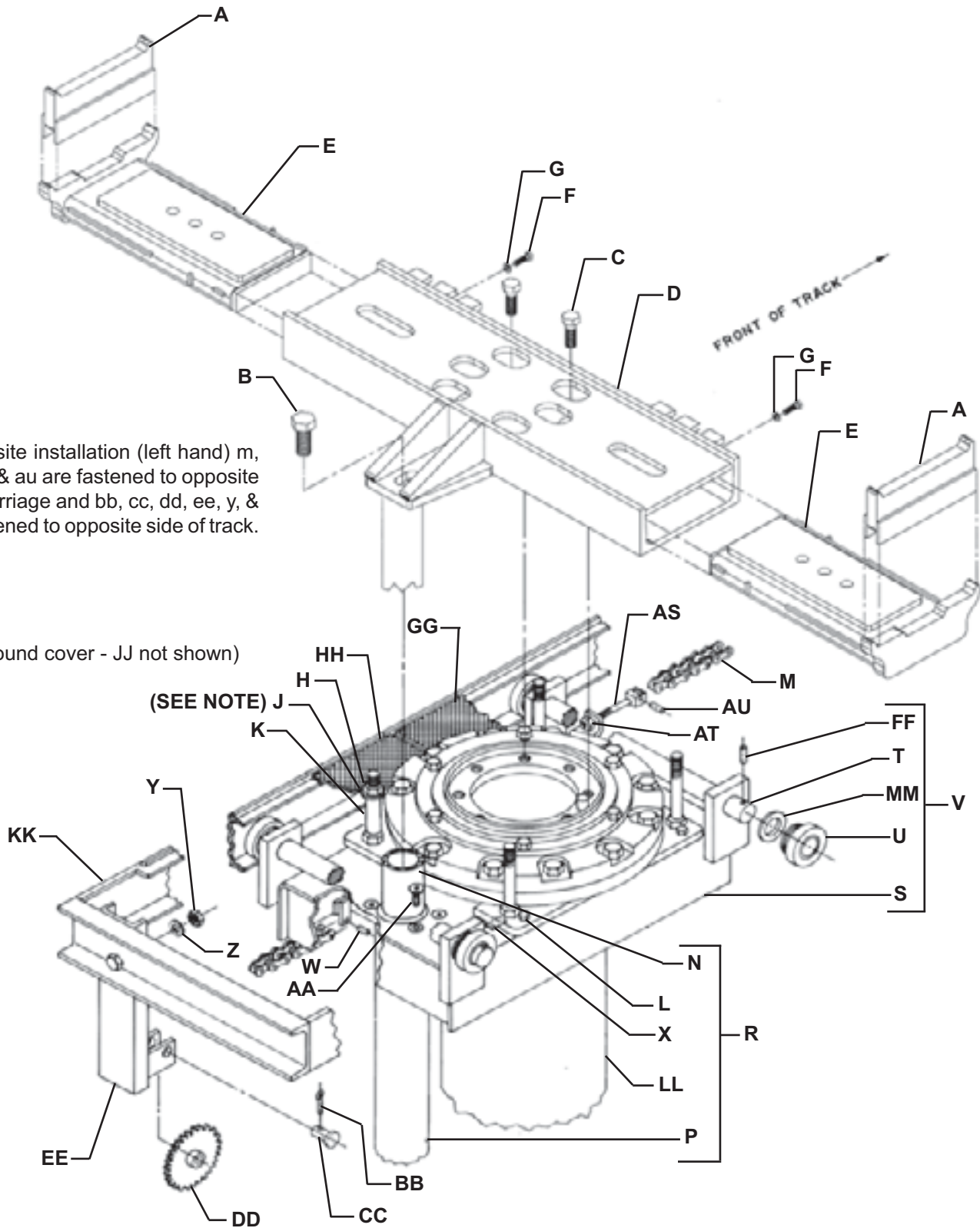

Fig. 22

Caution:
Pump rotation **MUST** be clockwise when facing pump from shaft end.

Pour 1/4 to 1/2 quart of hydraulic oil here to prime pump prior to start-up.

Parts List For Forward Pick-Up Base and Carriage Assembly With Remote Control Lock Leg



Note:

For opposite installation (left hand) m, w, as, at, & au are fastened to opposite side of carriage and bb, cc, dd, ee, y, & z are fastened to opposite side of track.

(Carry around cover - JJ not shown)

Note:

Washer must not contact cover plates or carriage will not move.

Fig. 8

Forward PickUp Base and Carriage Assembly With Remote Control Lock Leg Parts List

When ordering replacement parts, always mention lift model number and serial number.

Code No.	No. Req.	Symbol No.	Description	Code No.	No. Req.	Symbol No.	Description
A	2	R13323	Height Adapter	JJ	4	R13299	Cover Assembly (13 Ft. and 14 Ft.)
B	1	K01914-50	Hex Hd. Bolt 1"-8 x 2-1/2"	JJ	5	R13299	Cover Assembly (15 Ft. and 16 Ft.)
C	6	Q10412-01	Hex Hd. Bot 3/4"-10 x 2-1/4"	JJ	6	R13299	Cover Assembly (17 Ft. and 18 Ft.)
D	1	T13949	Forward Pickup Base	JJ	7	R13299	Cover Assembly (19 Ft. and 20 Ft.)
E	2	R13487	Forward Pickup Slide	JJ	8	R13299	Cover Assembly (21 Ft. and 22 Ft.)
F	2	K01902	Hex Hd. Bolt 3/8"-16 x 1"	KK	1	R19000-01	Track Kit (10 Ft.)
G	2	K50775	Lockwasher 3/8"	KK	1	R19000-02	Track Kit (11 Ft.)
H	8	K01948	Hex Nut 3/4"-10	KK	1	R19000-03	Track Kit (12 Ft.)
J	4	K06011	Flat Washer	KK	1	R19000-04	Track Kit (13 Ft.)
K	4	K88446-06	Spacer	KK	1	R19000-05	Track Kit (14 Ft.)
L	4	K01914-40	Hex Hd. Bolt 1/2"-13 x 2-1/2"	KK	1	R19000-06	Track Kit (15 Ft.)
M	1	K89040-17	Chain (10 Ft.)	KK	1	R19000-07	Track Kit (16 Ft.)
M	1	K89040-24	Chain (11 Ft.)	KK	1	R19000-08	Track Kit (17 Ft.)
M	1	K89040-18	Chain (12 Ft.)	KK	1	R19000-09	Track Kit (18 Ft.)
M	1	K89040-25	Chain (13 Ft.)	KK	1	R19000-10	Track Kit (19 Ft.)
M	1	K89040-19	Chain (14 Ft.)	KK	1	R19000-11	Track Kit (20 Ft.)
M	1	K89040-26	Chain (15 Ft.)	KK	1	R19000-12	Track Kit (21 Ft.)
M	1	K89040-20	Chain (16 Ft.)	KK	1	R19000-13	Track Kit (22 Ft.)
M	1	K89040-27	Chain (17 Ft.)	LL	1	T13944-02	Plunger and Cylinder Assembly (See Page 24)
M	1	K89040-21	Chain (18 Ft.)	MM	4	K89458	Washer
M	1	K89040-28	Chain (19 Ft.)	NN	1	Q10850-01	Breather Vent
M	1	K89040-22	Chain (20 Ft.)	PP	1	Q10167-10	Clevis Pin 1/4" Dia. x 1-1/4"
M	1	K89040-29	Chain (21 Ft.)	RR	1	K89571-01	Linkage Bar
M	1	K89040-23	Chain (22 Ft.)	SS	1	K82287-24	Set Screw #10-32 x 1/4"
N	1	T18522-G1	Inner Post Assembly	TT	1	N23000	Mounting Bar
P	1	N21352	Outer Post Assembly	UU	1	Q10404-03	Jam Nut 3/4"-16
R	1	K93578-G1	Remote Control Leg Assembly	VV	1	N23001	Mounting Bracket
S	1	T18514-G1	Carriage Weldment	WW	1	K90133	Air Cylinder
T	2	N20283	Carriage Axle	XX	5	K66871	Washer
U	4	K89017	Carriage Wheel Assembly	YY	3	Q10038-19	Spiral Pin 3/32" Dia. x 5/8"
V	1	T18515-G1	Carriage Assembly (Includes S, T, U, FF, & MM)	ZZ	4	K05287	Hex Hd. Bolt 1/4"-20 x 1/2"
W	1	K78378-39	Roll Pin 3/16" Dia. x 1-3/8"	AB	1	K91205	Spring
X	16	K88438	Shim	AC	2	Q10167-09	Clevis Pin 1/4" Dia. x 1"
Y	2	K01945	Hex Nut 1/2"-13	AD	1	K03782	Hex Hd. Bolt 5/16" x 1-3/4"
Z	6	K02455	Lockwasher 1/2"	AE	1	K02205	Flat Washer 5/16"
AA	4	Q10098-48	Flat Hd. Screw 3/8"-16 x 3/4"	AF	1	K77749-05	Spacer
BB	1	R18230-122	Cotter Pin 1/8" Dia. x 1"	AG	1	N21356	Jaw Assembly (Front R.H.)
CC	1	Q10167-13	Clevis Pin 5/8" x 1-3/4"	AH	1	N21357	Jaw Assembly (Front L.H.)
DD	1	K90624	Sprocket Assembly	AJ	1	K90171	Hose Clamp
EE	1	N21712-01	Sprocket Support (Rear)	AK	2	K01941	Hex Nut 1/4"-20
FF	4	K50511	Roll Pin 3/16" Dia. x 2"	AL	1	K90150-01	Air Hose
GG	1	R13389-04	Cover Assembly	AS	1	K90604	Anchor Rod Assembly
HH	1	R13389-05	Cover Assembly	AT	1	Q10977-03	Locknut 5/16"-18
JJ	3	R13299	Cover Assembly (10 Ft., 11 Ft., and 12 Ft.)	AU	1	K78378-48	Roll Pin 5/32" Dia. x 3/4"

Fitting Schedule

ITEMS FURNISHED BY INSTALLER

Code	No.	Description
	1	Nipple, 1/8" x 6" lg.
	2	Elbow, 1/8" x 90°
	3	Street Elbow, 1/8" x 90°
	4	Nipple, 1/8" x 1-1/2" lg.

WHEN ORDERED WITH LIFT, PARTS SHOWN ARE SHIPPED ASSEMBLED EXCEPT FOR ITEMS UNDERLINED.

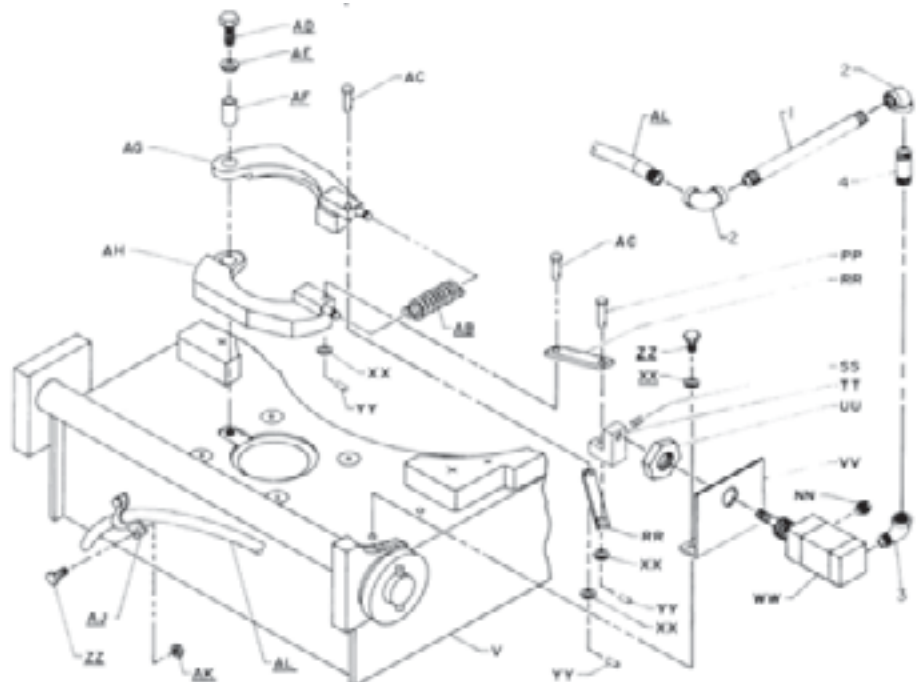

R14611

Fig. 10

Rear Trench Box and Axle Supports

When ordering replacement parts, always mention lift model number and serial number.

Code No.	No. Req.	Symbol No.	Description
A	2	R19030	Rear Axle Support
B	4	K50775	Lockwasher 3/8"
C	8	K51954	Hex Hd. Bolt 3/8-16 x 1/2"
D	8	Q10412-01	Hex Hd. Bolt 3/4-10 x 2-1/4"
E	8	R18230-171	Lockwasher 3/4"
F	1	T18510	Rear Axle Support Beam
G	1	Q10157-02	Grease Fitting
H	4	K01914-61	Hex Hd. Bolt 3/4-10 x 1-1/4"
J	1	T19000-G1	Inner Post Assembly
L	1	N23002	Outer Tube Assembly
M	1	K95002-G1	Remote Lock Leg Asm. (Includes J & L)
N	2	K78378-48	Roll Pin 5/32" Dia. x 3/4"
P	2	T18516-G1	Rear Box Door
Q	1	T18519-G1	Rear Box
R	4	K88461	Top Hinge
S	8	Q10098-48	Flat Hd. Screw 3/8-16 x 3/4"
T	1	T18520-G1	Rear Box & Door Asm. (Includes P, Q, R, & S)

Code No.	No. Req.	Symbol No.	Description
U	2	K88445-01	Door Closer
V	4	K01948	Hex Nut 3/4-10
W	4	K01914-40	Hex Hd. Bolt 1/2-13 x 2-1/2"
X	2	R14568	Wheel Locator
Y	6	K66314	Flat Washer 3/8"
Z	4	K01943	Hex Nut 3/8-16
AA	4	K01901	Hex Hd. Bolt 3/8-16 x 3/4"
BB	4	K89033	Anchor Rod
CC	16	K02204	Flat Washer 1/4"
DD	16	K01941	Hex Nut 1/4-20
EE	1	T14000-G1	Dual Plunger & Cylinder Asm. (See Page 25)

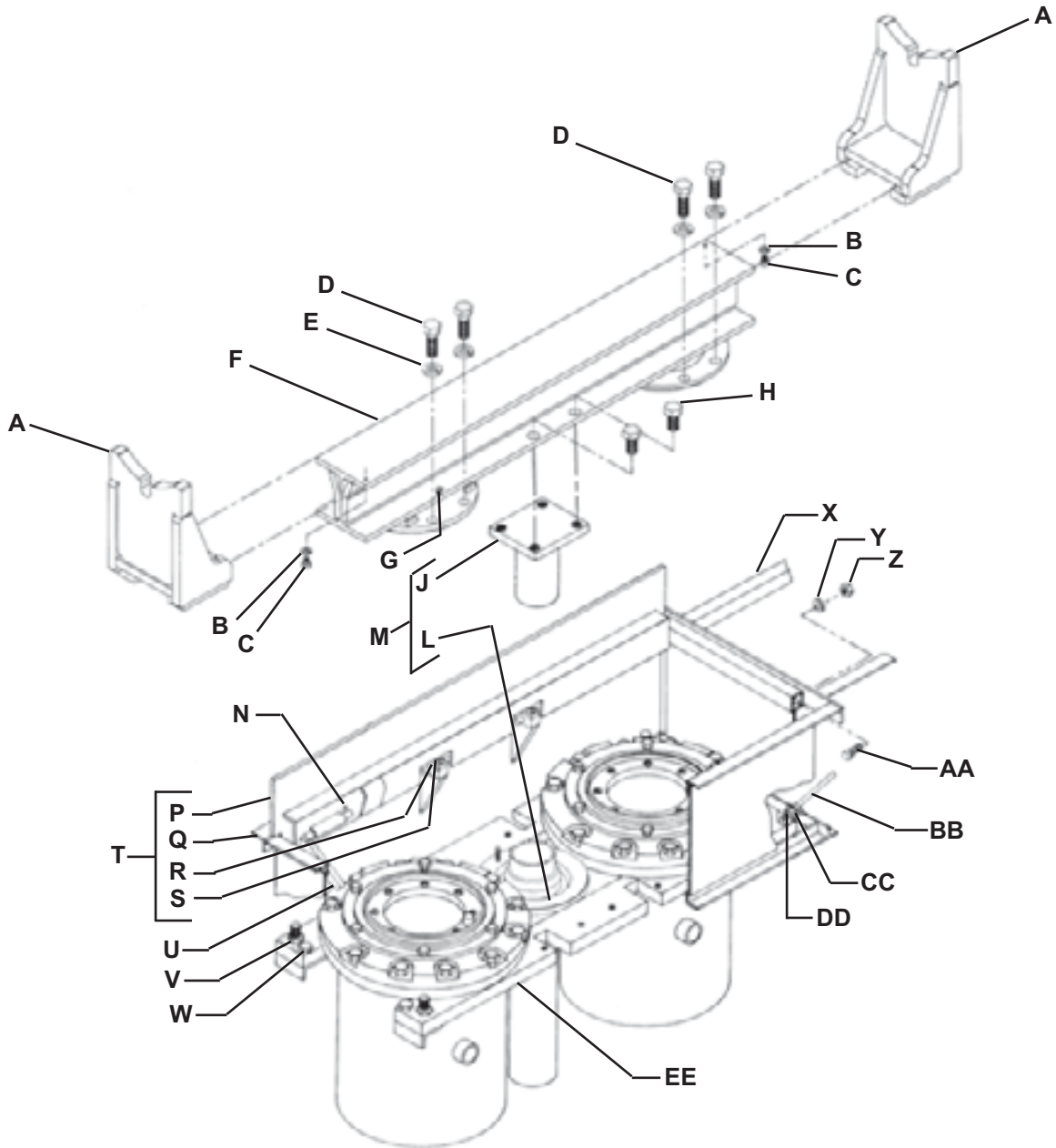

Rear Trench Box and Remote Control Parts

When ordering replacement parts, always mention lift model number and serial number.

Code No.	No. Req.	Symbol No.	Description	Code No.	No. Req.	Symbol No.	Description
FF	2	K05287	Hex Hd. Bolt 1/4-20 x 1/2"	YY	1	K57834	Street Elbow 1/8" x 90°
GG	1	T13113	Cover Bracket	XX	1	K91205	Spring
HH	1	T13112	Cover Support Bracket	AB	2	K66871	Flat Washer
JJ	2	Q10167-09	Clevis Pin 1/4" Dia. x 1"	AC	1	K95002	Remote Control Leg Assy. (Includes AL & Am)
KK	1	K82287-24	Set Screw #10-32 x 1/4"	AD	1	K90150-02	Air Hose
LL	3	K86601-04	Washer	AE	1	T13115	Cover
MM	2	K89571-02	Linkage Bar	AF	1	K01942	Hex Nut 5/16"-18
NN	3	Q10038-19	Spiral Pin 3/32" Dia. x 5/8"	AG	1	K02205	Flat Washer 5/16"
PP	1	Q10167-08	Clevis Pin 1/4" Dia. x 1-3/4"	AH	1	K77749-04	Spacer
RR	1	K90181	Spacer	AJ	1	N21344	Jaw Assembly (Rear R.H.)
SS	1	N21373	Actuator Assembly	AK	1	N21345	Jaw Assembly (Rear L.H.)
TT	1	Q10404-03	Jam Nut 3/4"-10	AL	1	T19000-G1	Inner Post Assembly
UU	1	R14606-02	Mounting Bracket Assembly	AM	1	N23002	Outer Post Assembly
VV	1	K90133	Air Valve	AN	1	Q10850-01	Breather Vent
WW	1	K90198	Wear Block	AP	1	K40379	Coupling 1/8"
XX	4	K02061-34	Flat Hd. Screw #10-32 x 3/4"	AR	1	N16927-17	Pipe 1/8" x 11"

WHEN ORDERED WITH LIFT, PARTS SHOWN ARE SHIPPED ASSEMBLED EXCEPT FOR ITEMS UNDERLINED

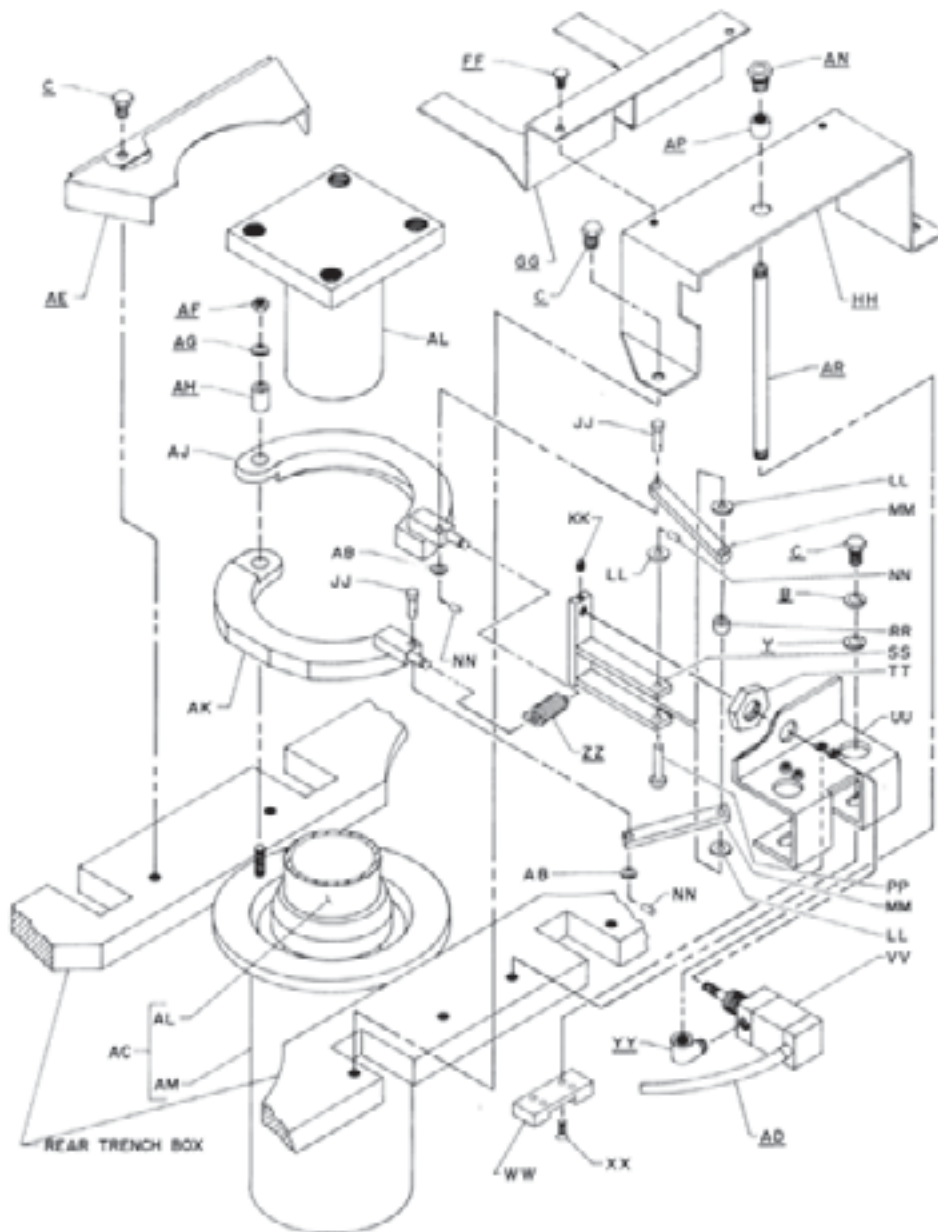

Extension Box And Control Box

When ordering replacement parts, always mention lift model number and serial number.

Code No.	No. Req.	Symbol No.	Description	Code No.	No. Req.	Symbol No.	Description
A	1	R16171-02	Ratchet Handle	U	1	K95071	Stop Bracket
B	1	T13872-01	Extension Box Cover	V	1	N21460	Ratchet Support Bar
C	16	K05287	Hex Hd. Bolt 1/4"-20 x 1/2"	W	1	N21714	Handle Holder Assembly
D	10	K01902	Hex Hd. Bolt 3/8"-16 x 1"	X	1	K78378-39	Roll Pin 3/16" Dia. x 1-3/8"
E	1	N21456	Bearing Mounting Bracket	Y	1	N17706-40	Flanged Bearing
F	1	K90615	Sprocket	Z	1	N21474	Ratchet Support Weldment
G	1	K90616	Split Taper Bushing	AA	1	N21470	Ratchet Support Assembly (Includes Y & Z)
H	3	K95216	Hex Hd. Bolt 5/16"-18 x 1"	BB	2	Q10033-69	Socket Hd. Cap Screw 1/4"-20 x 3/4"
J	1	K90618	Pillow Block	CC	1	K90609	Pivot Block
K	6	K02206	Flat Washer 3/8"	DD	6	K81038-24	Speed Nut 1/4"-20
L	14	K50775	Lockwasher 3/8"	EE	1	T09499-05	Side Panel Weldment (R.H.)
M	12	K01943	Hex Nut 3/8"-16	FF	1	T19045	Control Box Assembly (See Page 12)
N	2	N21466	Support Bracket	JJ	1	T09499-06	Side Panel Weldment (L.H.)
R	1	N21717-01	Sprocket Shaft Assembly				
S	8	K43948	Lockwasher 1/4"				
T	6	K01941	Hex Nut 1/4"-20				

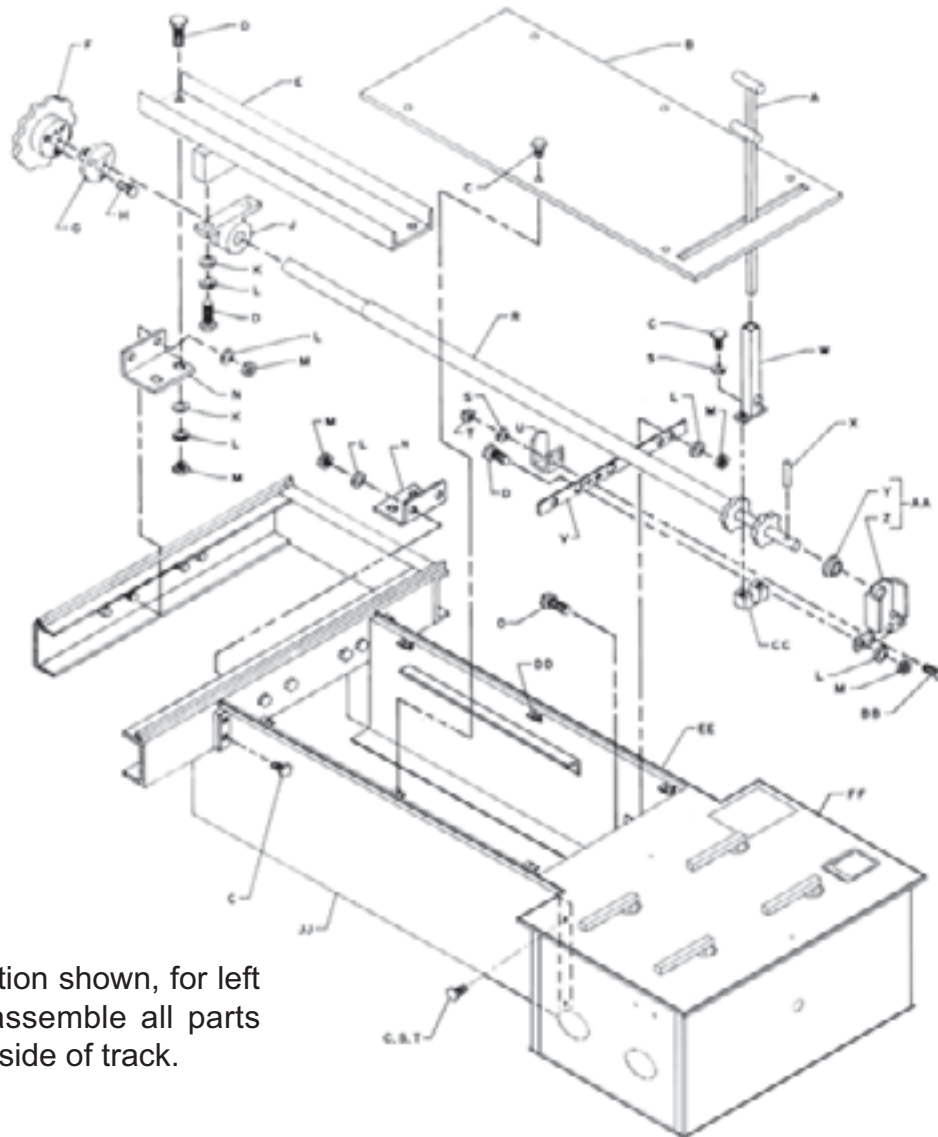

Note:

Right hand installation shown, for left hand installation assemble all parts shown to opposite side of track.

Fig. 13

Extension Box And Control Box With Optional Power Carriage

When ordering replacement parts, always mention lift model number and serial number.

Code No.	No. Req.	Symbol No.	Description	Code No.	No. Req.	Symbol No.	Description
A	1	R16171-02	Ratchet Handle	U	1	K95071	Stop Bracket
B	1	T13894	Extension Box Cover	V	1	N21460	Ratchet Support Bar
C	16	K05287	Hex Hd. Bolt 1/4"-20 x 1/2"	W	1	N21714	Handle Holder Assembly
D	12	K01902	Hex Hd. Bolt 3/8"-16 x 1"	X	1	K78378-39	Roll Pin 3/16" Dia. x 1-3/8"
E	1	N21740	Bearing Mounting Bracket	Y	1	N17706-40	Flange Bearing
F	2	K90615	Sprocket	Z	1	N21474	Ratchet Support Weldment
G	2	K90616	Split Taper Bushing	AA	1	N21740	Ratchet Support Assy (Includes Y & Z)
H	6	K95216	Hex Hd. Bolt 5/16"-18 x 1"	BB	2	Q10033-69	Socket Hd. Cap Screw 1/4"-20 x 3/4"
J	2	K90618	Pillow Block	CC	1	K90609	Pivot Hd.
K	8	K02206	Flat Washer 3/8"	DD	6	K81038-24	Speed Nut 1/4"-20
L	18	K50775	Lockwasher 3/8"	EE	1	T09499-05	Side Panel Weldment (R.H.)
M	14	K01943	Hex Nut 3/8"-16	FF	1	T19045	Control Box Assembly (See Page 12)
N	2	N21466	Support Bracket	JJ	1	T09499-06	Side Panel Weldment (L.H.)
R	1	N21717-01	Sprocket Shaft Assembly				
S	8	K43948	Lockwasher 1/4"				
T	6	K01941	Hex Nut 1/4"-20				

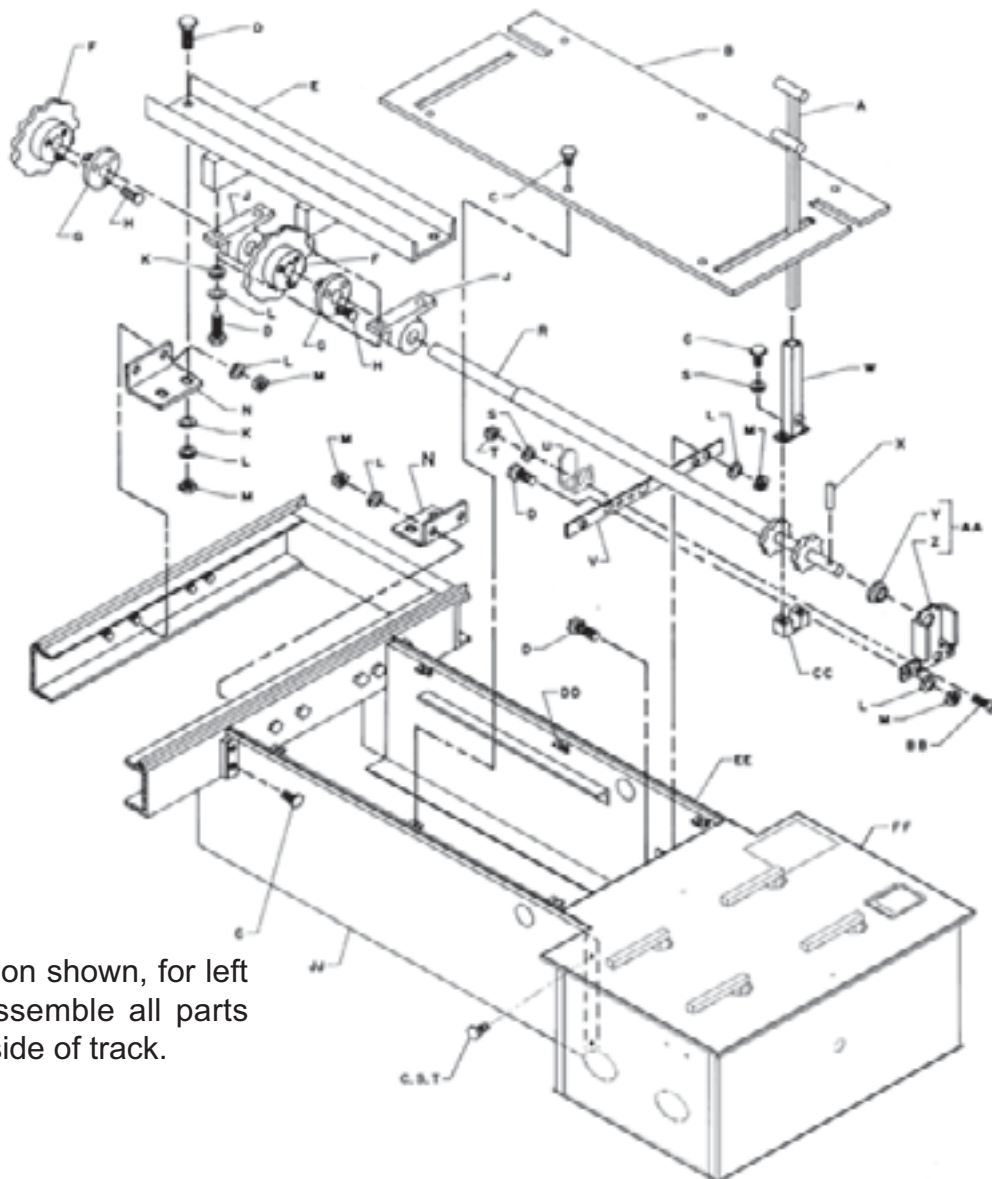

Note:

Right hand installation shown, for left hand installation assemble all parts shown to opposite side of track.

Fig. 15

Extension Box with Optional Power Carriage

When ordering replacement parts, always mention lift model number and serial number.

Code No.	No. Req.	Symbol No.	Description
D	8	K01902	Hex Hd. Bolt 3/8"-16 x 1"
K	6	K02206	Flat Washer 3/8"
L	18	K50775	Lockwasher 3/8"
M	14	K01943	Hex Nut 3/8"-16
N	2	N21466	Support Bracket
V	1	N21460	Ratchet Support Bar
KK	1	K95021	Roller Chain
LL	1	N21744	Motor Mounting Bracket
MM	1	K90614	Sprocket
NN	1	K61559	Key 1/4" x 1"
PP	1	N21475	Hydraulic Motor
RR	2	K01945	Hex Hd. Bolt 3/8"-16 x 1-1/2"
VV	1	K91952	Orifice

Code No.	No. Req.	Symbol No.	Description
XX	1	N21743	Control Handle
YY	1	K91950	Control Valve Shield
AE	1	R16223	Control Valve Assembly
AH	1	R16224	Valve Mounting Bracket
AJ	4	K01901	Hex Hd. Bolt 3/8"-16 x 3/4"
AK	1	K91951	Hydraulic Hose
AM	1	Q10850-01	Breather Vent
AN	2	Q10037-72	Socket Hd. Cap Screw #10-32
AP	1	N21739	Short Stroke Hydraulic Cylinder
AR	1	N21742	Cylinder Mounting Bracket
AS	2	K65235-22	Flat Washer #10
AT	2	K50866	Lockwasher #10
AU	2	K22733	Hex Nut #10-32

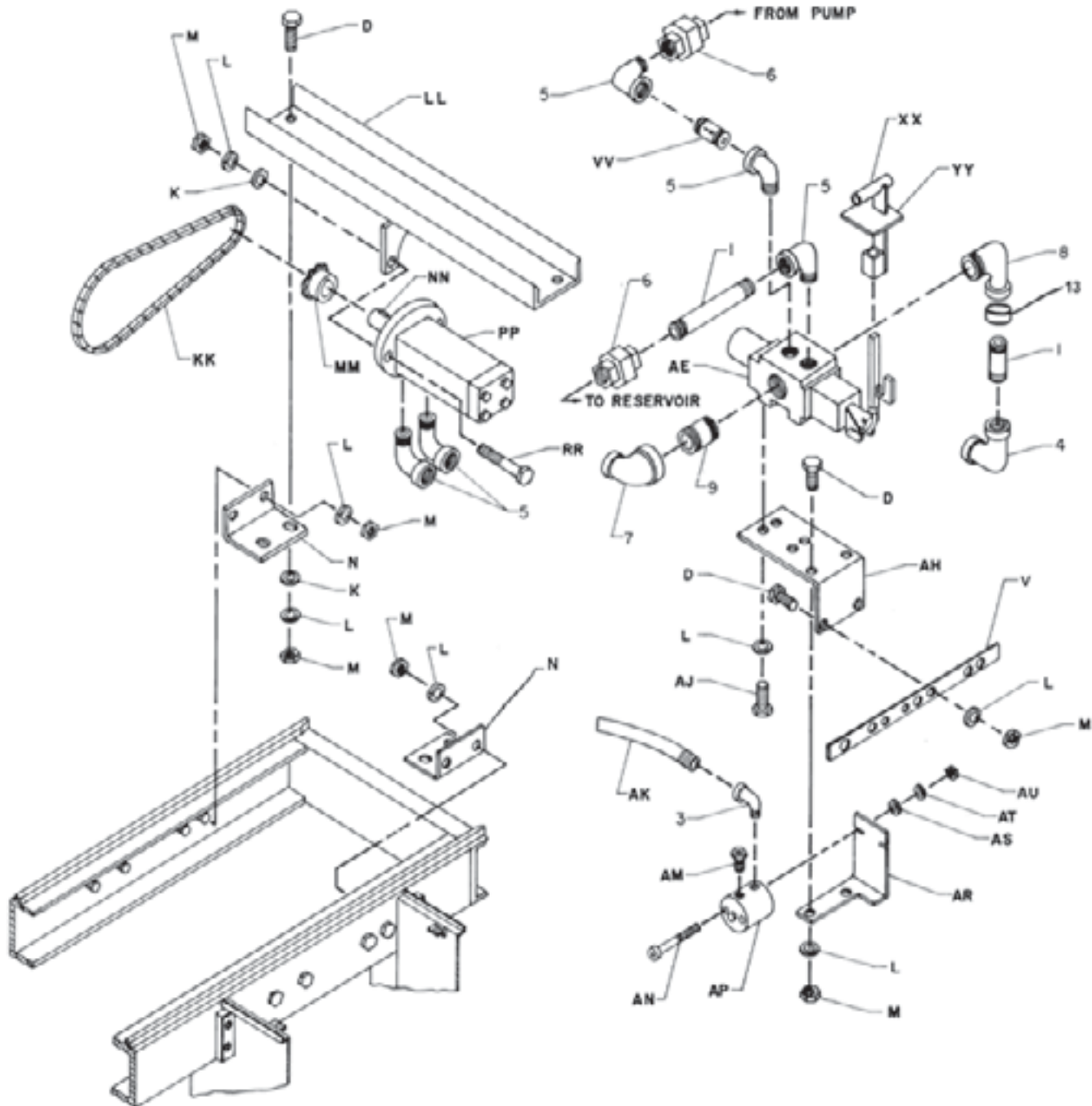

T13896

Fig. 16

Piping For Optional Power Carriage

When ordering replacement parts, always mention lift model number and serial number.

Code

No.	Description
1	Pipe, 1/2" Dia. Stl.
2	Pipe, 1-1/4" Dia. Stl.
3	Street Elbow, 1/8" x 90°
4	Elbow, 1/2" x 90°
5	Street Elbow, 1/2" x 90°
6	Union, 1/2"
7	Reducing Elbow, 3/4" to 1/2" x 90°
8	Street Elbow, 3/4" x 90°
9	Nipple, 3/4" x 2"
10	Tee, 1-1/4" x 1-1/4" x 1-1/4"
11	Reducer Bushing, 3/4" x 1/8"
12	Reducer Bushing, 1-1/4" x 3/4"
13	Reducer Bushing, 3/4" x 1/2"

ITEMS FURNISHED BY INSTALLER

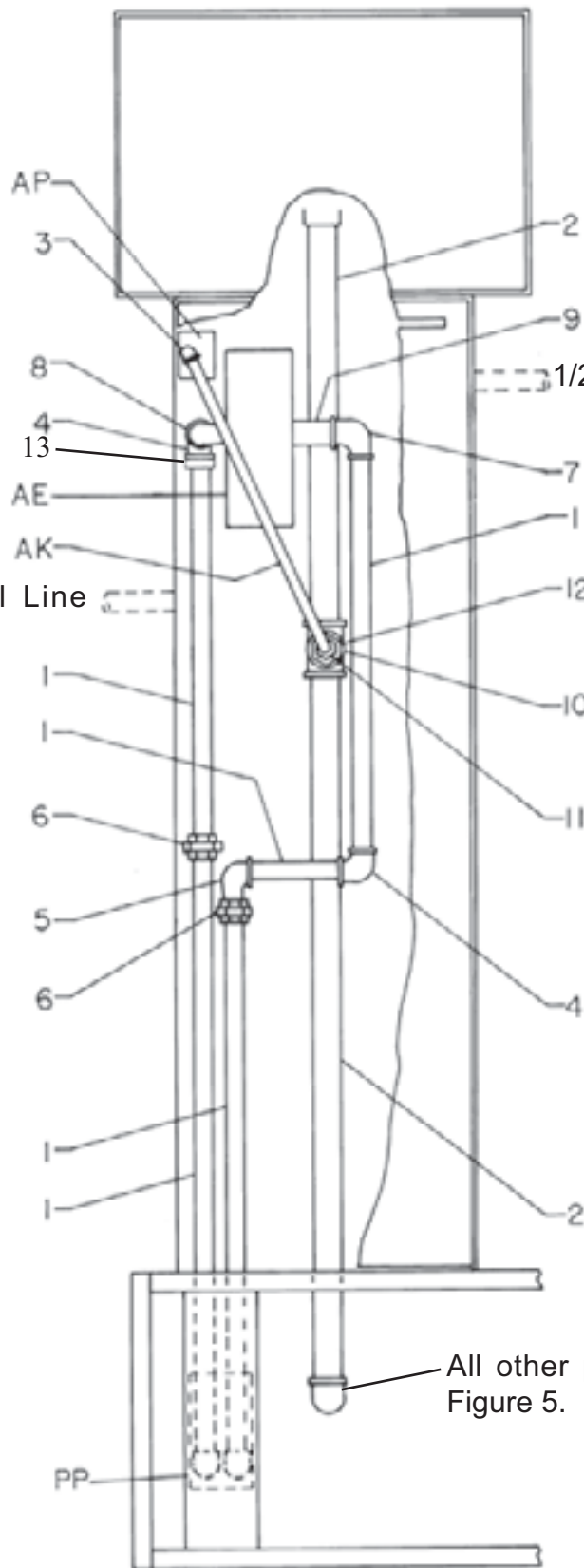

1/2" Pressure Oil Line
From Power Unit

1/2" Return Oil Line To Power Unit

All other piping same as shown in
Figure 5.

Plunger and Cylinder Assembly (Front)

When ordering replacement parts, always mention lift model number and serial number.

Code No.	No. Req.	Symbol No.	Description
A	1	T13944-02	Plunger and Cylinder Assembly
B	1	T13935-G2	Plunger Assembly
C	1	T13943-03	Upper Bearing
D	1		Felt Wiper
E	12	Q10412-01	Hex Hd. Bolt 3/4"-10 x 2-1/4"
F	1	R18229-02	Wiper Retainer
G	6	K01907	Hex Hd. Bolt 7/16"-14 x 1-1/2"
H	1		Wiper
J	1		Seal
K	1		O-Ring
L	1	K34301	Seal Kit (Includes C, G, H, and J)
	1	N21812-G1	Air Vent

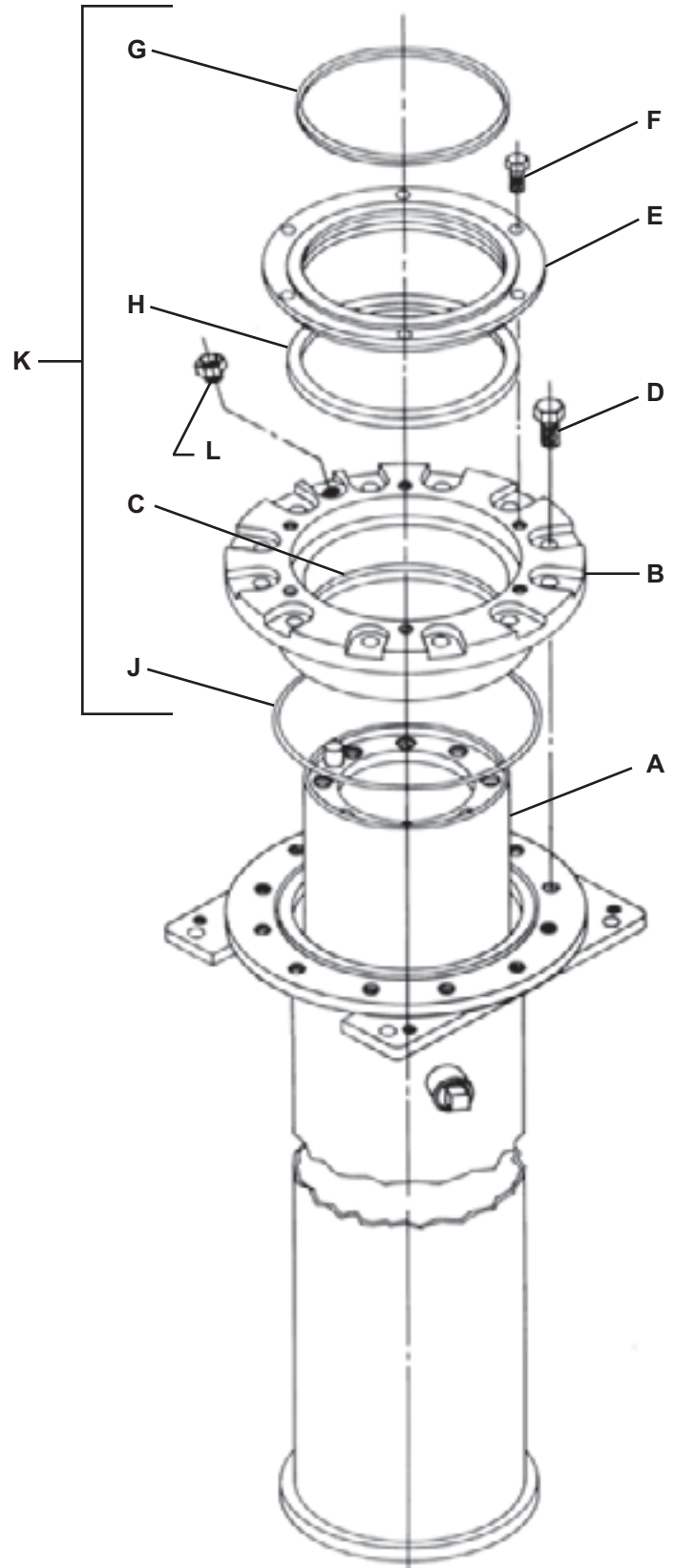

Note:

When ordering plunger assy., specify symbol no. and bearing code letter stamped on top of plunger. For replacement plunger, order kit no. K92936.

R16286

Plunger and Cylinder Assembly (Rear)

When ordering replacement parts, always mention lift model number and serial number.

Code No.	No. Req.	Symbol No.	Description
A	1	T14000-G1	Dual Plunger and Cylinder Assembly
B	1	T13935-G4	Plunger Assembly (See Note)
C	1	T13943-03	Upper Bearing
D	1		Felt Wiper
E	12	Q10412-01	Hex Hd. Bolt 3/4"-10 x 2-1/4"
F	1	R18229-02	Wiper Retainer
G	6	K01907	Hex Hd. Bolt 7/16"-14 x 1-1/2"
H	1		Wiper
J	1		Seal
K	1		O-Ring
L	1	K34301	Seal Kit (Includes C, G, H, and J)
	1	N21812-G1	Air Vent

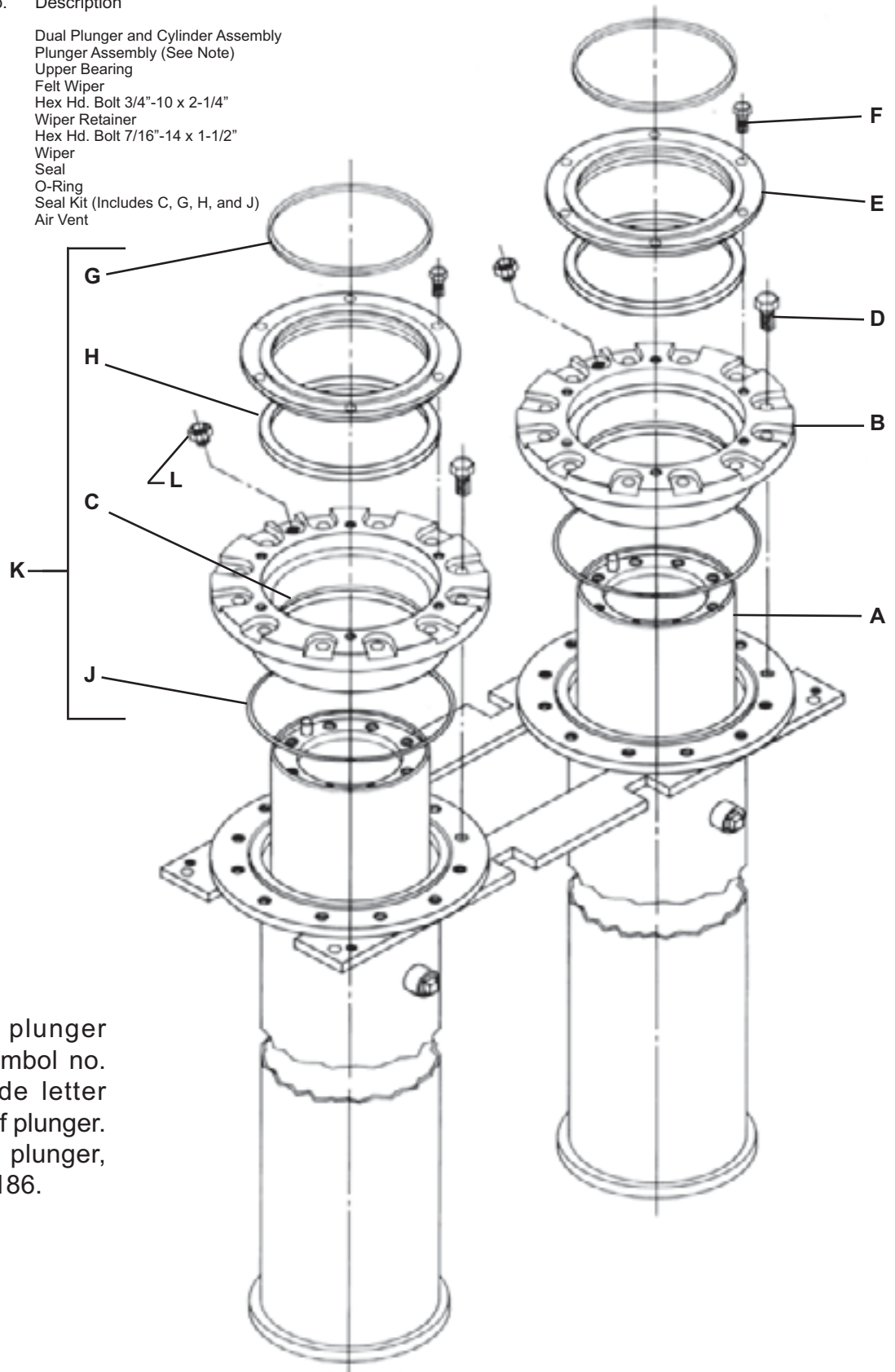

Note:



When ordering plunger assy., specify symbol no. and bearing code letter stamped on top of plunger. For replacement plunger, order kit no. K95186.

T18524

SAFETY WARNING LABELS FOR IN-GROUND LIFTS

Lift Owner/User Responsibilities:

- A. This Safety Warning placard **SHALL** be displayed in a conspicuous location in the lift area back of this placard
- B. Use one of the mounting arrangements illustrated on
- C. These Safety Warning labels supplement other documents supplied with the lift.
- D. Be certain all lift operators read and understand these labels, operating instructions and other safety related information supplied with the lift.

	▲ WARNING Do not override self-closing lift controls.
	▲ WARNING DO NOT remove oil fill plug before reading manufacturer's manuals.
	▲ WARNING Position vehicle center of gravity over lift.
	▲ WARNING Remain clear of lift when raising or lowering vehicle.
	▲ WARNING Keep feet clear of lift while lowering.
	▲ WARNING Clear area if vehicle is in danger of falling.
	▲ WARNING Avoid excessive rocking of vehicle while on lift.
	▲ WARNING Chock wheel to prevent vehicle movement.
	▲ WARNING Use lift locking device or 4 stands to support vehicle.
<p>The messages and pictographs shown are generic in nature and are meant to generally represent hazards common to all automotive lifts regardless of specific style.</p> <p>Funding for the development and validation of these labels was provided by the Automotive Lift Institute, PO Box 1519 New York, NY, 10101-1519.</p> <p>They are protected by copyright. Set of labels may be obtained from ALI or its member companies.</p> <p>© 1992 by ALL Inc. ALI-PWLS004</p>	

SAFETY WARNING LABELS

TYPICAL PLACARD LOCATIONS

<p>In-floor Lift Controls: Locate placard on wall or column in lift area near lift controls</p>	<p>Push Button Controls on Electric Powered Lifts</p>	<p>Air Supply To Lift</p>	<p>Wall Mounted Lift Control</p>	<p>CAUTION</p> <p>Use height extenders when necessary to ensure good contact.</p>	<p>CAUTION</p> <p>Always use safety stands when removing or installing heavy components.</p>	<p>CAUTION</p> <p>Use vehicle manufacturer's lift points.</p>	<p>CAUTION</p> <p>Authorized personnel only in lift area.</p>	<p>CAUTION</p> <p>Lift to be used by trained operator only.</p>	<p>SAFETY INSTRUCTIONS</p> <p>Do not operate a damaged lift.</p>	<p>SAFETY INSTRUCTIONS</p> <p>Proper maintenance and inspection is necessary for safe operation.</p>	<p>SAFETY INSTRUCTIONS</p> <p>Read operating and safety manuals before using lift.</p>	<p>CAUTION</p> <p>Auxiliary adapters may reduce load capacity.</p>	<p>SAFETY INSTRUCTIONS</p> <p>Proper maintenance and inspection is necessary for safe operation.</p>
--	--	----------------------------------	---	---	--	---	---	---	--	--	--	--	--

SAFETY WARNING LABELS

Notes

“As Installed” Piping Plan

INSTALLER: Sketch “As Installed” Piping Locations, In Case Future Excavation is Required.



MANITOWOC LIFTS

www.manitowoclifts.com

www.sviinternational.com

(800) 321-8173 • fax: (800) 899-1784

Main Office: 155 Harvestore Drive • DeKalb, IL