

MANITOWOC LIFTS

INSTALLATION INSTRUCTIONS AND PARTS LIST SWING RAIL TWO-POST FULL HYDRAULIC LIFTS

A-22E5A

**12,000 LBS CAPACITY @ 260-270 PSI
ELECTRIC OIL OPERATED**

Recommendations

PIPING: Use only new pipe. See that threads are perfect. Before using the pipe, hammer it to loosen all scale, spelter, and dirt, then wash the interior with kerosene. The pipe should pitch up gradually from the cylinder to the control valve with no traps or low places. Use pipe sealing compound on the male threads of all screw connections, unless your local authorities require the use of some special material. Do not use on female thread. Verify that all pipe joints are tight, with no leaks prior to backfill and pouring of concrete. All piping must be schedule 40 per ASTM A-53 Type E, Grade B. All fittings to be Malleable Iron, Class 300/PN 50. Do not use plastic piping, fittings, or valves.

**INSTALLATION MUST BE MADE IN ACCORDANCE WITH LOCAL, STATE AND FEDERAL
REGULATIONS AND IN STRICT CONFORMANCE WITH THESE INSTRUCTIONS.
USE ONLY MANITOWOC LIFTS AUTHORIZED REPLACEMENT PARTS**

- Warning -

- Do not pressurize system with shipping strap in place! Do not operate until system is properly filled with oil.
- The plunger top plates have foolproof pins which must be kept in line with the oil inlet coupling(180 deg. from the rack tube). The plunger should not be rotated in the cylinder. If plungers are removed, it must be oriented as stated above when put back in the cylinder.

- Caution -

After the plungers are installed and piping has been completed, fill the system with oil to protect the plungers from corrosion until the facility is opened. Do not raise plungers until oil has been added. If lift will not be installed within one week, fill plunger-cylinder assemblies with SAE 10 hydraulic oil.

THESE INSTRUCTIONS MUST BE THOROUGHLY READ AND FOLLOWED BY INSTALLER DURING INSTALLATION, AND THEN BY THE USER THROUGHOUT THE LIFE OF THE LIFT. THESE INSTRUCTIONS MUST ALSO BE THOROUGHLY READ AND FOLLOWED BY THE AUTHORIZED SERVICE CONTRACTOR DOING SERVICE WORK ON THE LIFT TO ASSURE PROPER ASSEMBLY OR DISASSEMBLY.

FOR PROBLEMS OR QUESTIONS WITH INSTALLATION, CALL OUR TOLL FREE HOTLINE: 800-783-5777



SVI International, Inc.
Manitowoc Lifts - An SVI Brand Product Line
155 Harvestore Drive, DeKalb, IL
www.manitowoclifts.com • www.sviinternational.com

GENERAL INFORMATION/FLOOR CONDITIONS

MANITOWOC LIFTS products are designed to give many years of trouble free operation if installed correctly and given proper care.

This lift operates on the full hydraulic principle which means that the load and lifting assembly are at all times supported on a continuous column of oil which extends from the cylinder to the oil control valve.

MANITOWOC LIFTS will not assume any responsibility or liability, financial, legal or otherwise, in connection with the installation of its lifts which goes beyond the stated limitations of the standard instruction sheet or drawings currently applying at the date of shipment, to individual models of MANITOWOC LIFTS.

In the event MANITOWOC LIFTS representatives consult with contractors, owners, or their employees regarding location of lift or any other matters such as layout, head room, or floor planning, this consultation shall not be taken as a representation of accuracy, and the Company will not assume any liability or responsibility in any manner whatsoever. It is suggested that an architect be consulted.

1. LOCATING THE LIFT: Proper location of a lift is essential to insure efficient usage and operation. Therefore a careful study should be made of the area available for installation.

CONSIDER:
DIRECTION OF TRAFFIC FLOW

APPROACH SPACE to allow adequate maneuver ability of the car.

WORKING AREA required around car.
Determine what floor conditions exist or will exist where the lift is to be installed.

FLOOR SLOPE - 1/8" per ft. drainage slope away from lift recommended.

HEADROOM above lift. Provide ceiling clearance for your highest vehicle when the lift is raised.

The sketches below show two types of installation: -one showing a lift perpendicular or parallel to a wall, and the other, a lift at an angle to a wall. (The latter used when sufficient approach space is not available.)

Note recommended 3 ft. minimum clearance aisle and space for a work bench provided in front of car. (Fig. 1).

Note clearance required on either side of car of opening doors.

When two or more lifts are installed adjacent to one another, they should be set with a recommended distance of 12 feet between center lines of lifts. It is possible to located adjacent lifts 10 ft. apart, but this spacing should be used only when absolutely necessary.

Location of the lift control valve is optional to some extent and must be determined to best suit the installation. Controls should be located to give the operator a clear unobstructed view of the lift.

2. **IMPORTANT**
Inspect cylinders for shipping damage and check drain plug for tightness before cylinder assembly is installed.

NOTE: Dimensions indicated in sketches are recommended minimum only.

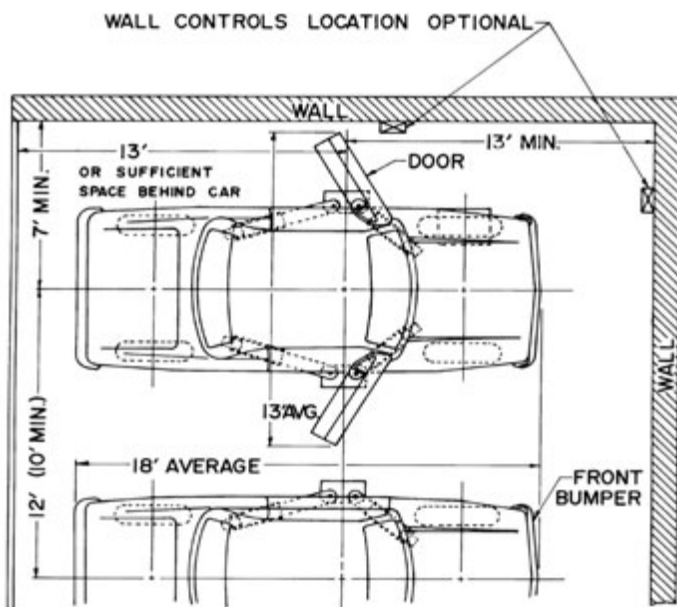

FIG. 1A

T0932I

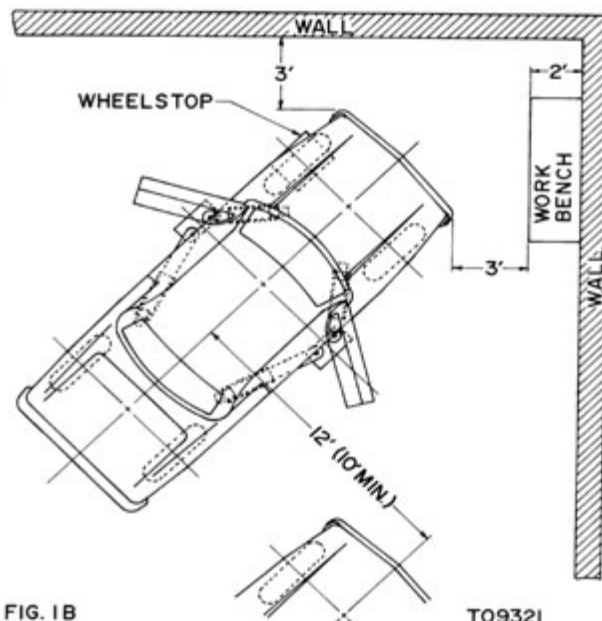

FIG. 1B

T0932I

3. Determine lift location and provide proper working space and clearance as outlined in previous section "Locating the Lift." After determining lift location, excavate a hole, centered on this position to receive the two-post plunger-cylinder assembly with racks, pinions, and housings assembled. Dimensions of this excavation are shown in Fig. 2. Pour concrete slab in the bottom of the plunger-cylinder excavation. The approximate dimensions of this slab are shown in Fig. 2.

INSTALLATION INSTRUCTIONS

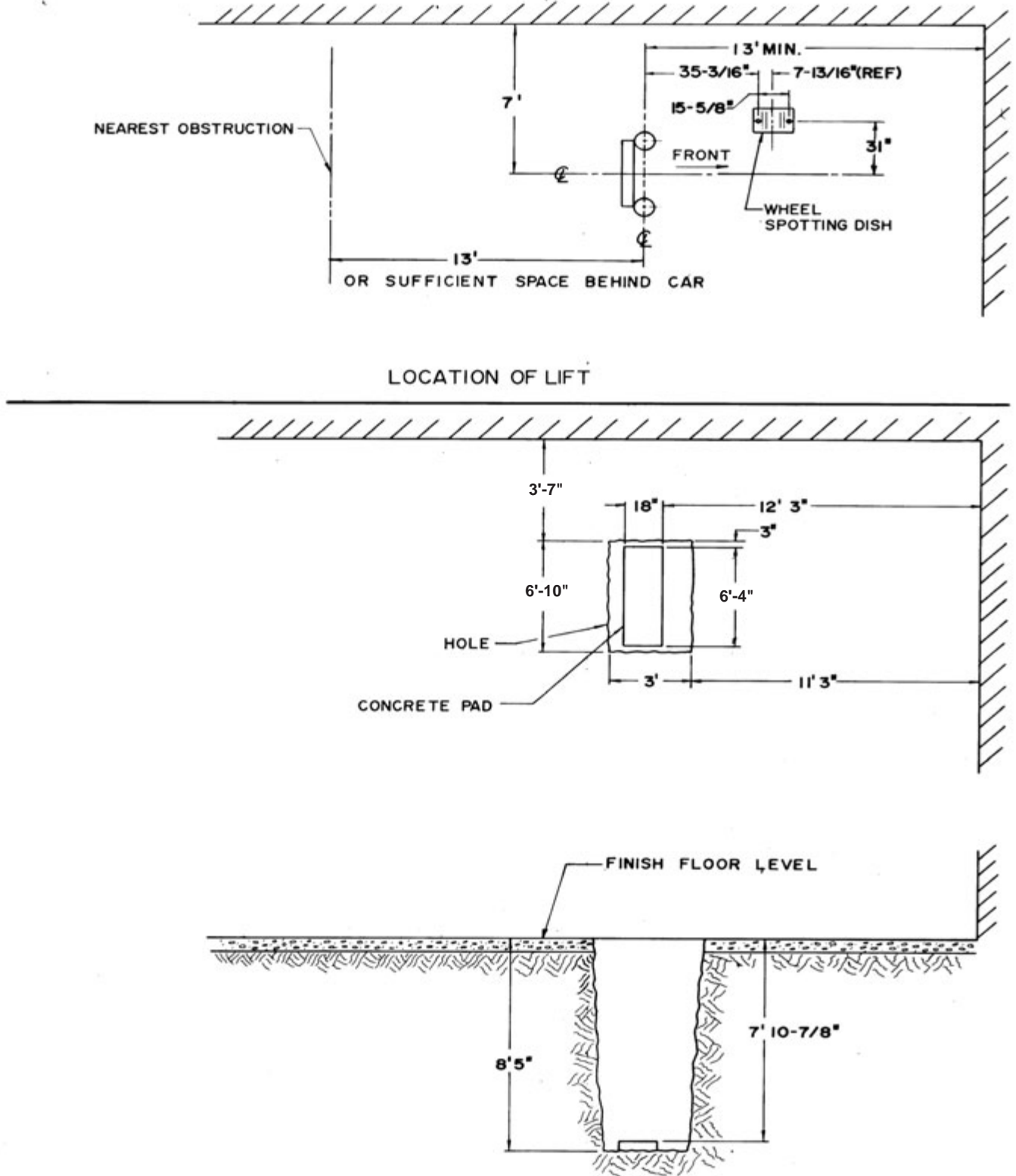

Fig. 2

Location of Hole

4. ASSEMBLING PLUNGER-CYLINDER (See Fig. 10)

- A. Position the (2) plunger-cylinder assemblies (A) on wooden horses or equivalent. Make sure that the horses are level and the rack tubes on the plunger/cylinder assemblies are facing up.
- B. Fasten the top of the plunger-cylinder assemblies together by bolting the upper brace (E) to the cylinder bolt ring using (4) hex hd. bolts (C). Fasten the bottom of the plunger-cylinder assemblies together by bolting the lower brace (B) to the cylinder bottom plate using (4) hex hd. bolts (C) and (4) washers (D). These (8) hex. hd. bolts (C) should be snug but yet allow some movement for alignment.
- C. Install the (2) tie rods (F & G) crisscross to the plunger-cylinder assemblies (A) with the turn buckles (H) toward the top.
- D. Adjust the entire assembly to the center-to-center dimensions and diagonal dimensions as shown in Fig. 5.
- E. With plunger-cylinder assemblies aligned, wrench hex. hd. bolts (C), that hold upper and lower braces, full tight.
- F. Fasten (2) pinion box end sections (K) to top of rack tube using (4) hex hd. bolts (L).
- G. Fasten pinion box center section (J) to end sections of box using (8) speed nuts (JJ) and (8) hex. hd. bolts (L).
- H. Insert square keys (V) into slots in pinion shaft (N). Using a light lubricating oil, lube pinion shaft (N) ends and pinion supports (P & Q) sleeve bearings.
- I. While holding the pinion gear (W) in the R.H. pinion support (P), insert the pinion shaft (N) thru the clearance hole in the pinion support; thru the pinion gear (W) and in thru the bearing on the far side of the pinion support.
- J. Secure the end of the pinion shaft on the outside of the pinion support using washer (T) and retaining ring (U).
- K. Repeat steps "I" and "J" for L.H. end of pinion shaft using pinion support (Q).
- L. INSTALL AUTOMATIC LATCHES as shown in Fig. 9.
- M. Using (8) hex. hd. bolts (R) and (8) washers (S), fasten the complete assembly made above to the plates on top of the rack tubes. Snug The Bolts But Do Not Tighten Them.
- N. Slide the (2) racks (BB) into the pinion supports so that tooth engagement is equal to each other.

5. POSITIONING PLUNGER-CYLINDER IN EXCAVATION.

Using a 2000 pound capacity chain hoist with at least 9'-0" clear swing, lower the plunger-cylinder assembly into excavation. NOTE: Rack and pinion assembly of the lift is to be located on the same side as the direction of approach of vehicle. A rope sling around each of the plunger-cylinder assemblies is recommended. **CAUTION:** Do not lift the plunger-cylinder assembly into excavation from the center of the upper or lower braces. After plunger-cylinders have been positioned in excavation and temporarily blocked, shim under lower brace (B) to bring the top of the concrete ring (around cylinder bolt ring) flush with the final floor grade. Using a spirit level, as shown in Fig. 5, adjust each plunger-cylinder to be plumb and parallel to each other. It may be necessary to make minor adjustments to the tie rods to obtain these conditions. This operation is very important for a satisfactory Installation. Block assemblies securely after final level and plumb adjustments.

6. COMPLETE PIPING as shown in Fig. 4. Location of oil reservoir tank is optional. Install wall control valve assembly as shown on page 12.

7. FILL SYSTEM WITH OIL. The oil capacity requirements are approximately 60 gallons. Use only hydraulic lift oils recommended by petroleum manufacturers for use in hydraulic lifts. Viscosity rating should be approximately 100-125 SSU

at 100EF. Most SAE 10 oils (new) are acceptable. Avoid oils which foam under air pressure. A rust inhibitive oil is strongly recommended.

WARNING - Do not use pressurize system with shipping strap in place! Do not operate until system is properly filled with oil! Follow the steps given below, keeping in mind that the system must be filled and bled gradually.

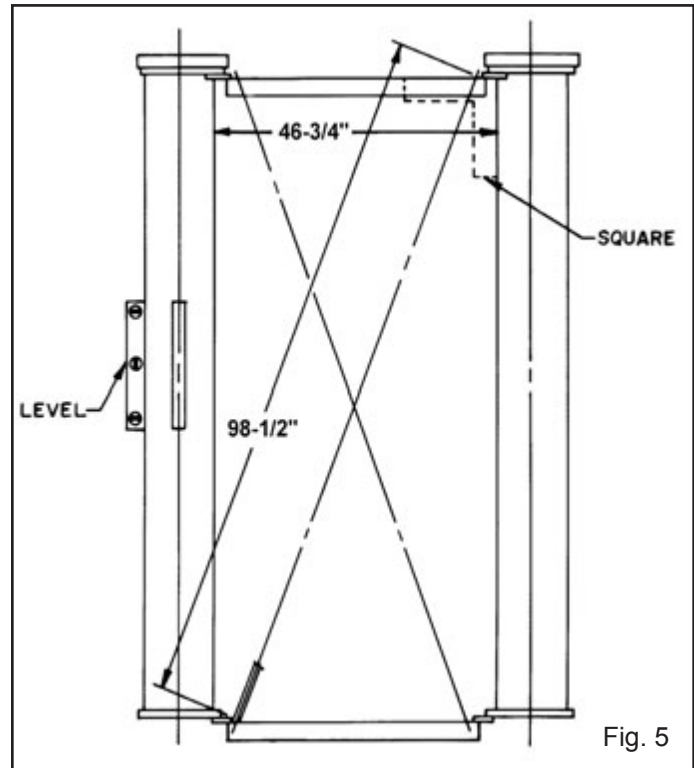

Fig. 5

- A. Remove Shipping Strap, discard it and the 3/8" bolts and lockwashers.
- B. Loosen air vent plugs (located in top cylinder castings.)
- C. Fill reservoir to the full level on the oil gauge for (1) 22E lift, or approximately 60 gallons.
- D. Bleed air from cylinders by gradually admitting oil to cylinders by means of the oil control valves. Air will escape from air vents. When a steady stream of oil flows freely from air vent holes, close oil control valves and tighten air vent plugs. Raise plungers no more than 3 ft. Close oil control valves. Observe all joints for leaks.
- E. Open oil control valves until plungers are completely lowered. Check oil level in reservoir using the oil gauge. Add sufficient oil in reservoir to bring the oil level between the lines on oil gauge for (1) 22E lift (see page 15). Replace oil gauge.
- F. Repeat bleed and refill procedure until no air escapes from air vent.
8. IMBED BASE OF CYLINDERS IN 4" MIN. OF CONCRETE & AT LEAST 3" THICK AROUND CYLINDERS. See figure 4.
9. BACK FILLING. The excavation should be back filled with clean sand one foot at a time followed by solid tamping. Do not use cinders or other corrosive fill material.
CAUTION: Do not force the plunger-cylinder assemblies if they should be out of plumb, but remove sand and re-plumb the units. **CAUTION:** Do not allow dirt to enter rack and pinion area during back filling.

10. **COMPLETE BACK FILLING AND FINAL POURING OF CONCRETE FLOOR.**
Pour concrete floor. Protect the rack and pinion from concrete. Grease (4) 3/8-16 x 3/4 lg. hex hd. bolts and screw into pinion box support plates to prevent concrete from plugging holes. Be sure to pour concrete under pinion box support plates. See FIG. 7. Do not allow concrete to splash or pour into housings. Allow concrete to cure at least 24 hours.
11. **BALLAST SHOULD BE PROVIDED FOR BOTH PLUNGERS.** This may be accomplished by filling the hollow of the plungers with a mixture of clean oil and sand, (no foundry sand), is recommended. Care should be taken not to let sand get into packing area by providing a funnel of some type.
12. **ASSEMBLING OF SUPERSTRUCTURES. (FIG.6)**
Position the swing arm anchor plate on the plunger, by first locating
 - A. the "Foolproof Pin" opposite the rack tube. Bolt swing arm anchor plate to top of plunger with the appropriate hardware shown for your particular lift. These bolts have a minimum tensile strength of 150,000 PSI.
 - B. Place the pinion box end covers (HH) over the rack assembly. (Do not bolt in place yet.)
 - C. Fasten the swing arm anchor plate to rack assy. (BB) using screw (CC) and locking nut (DD) as shown in Fig. 10.
CAUTION - Be sure that the screw goes completely through the jam nut and protrudes out the other side in order to prevent the nut from backing off. Do not wrench the locking nut full tight. Allow movement between the rack and swing arm anchor plate.
 - D. Cycle lift once or twice to allow rack assy. to properly position both pinion supports.
 - E. Tighten mounting bolts (R) for both the pinion supports now.
 - F. Lubricate rack teeth with light grease.
 - G. Secure (2) pinion box end covers (HH) to pinion box end sections with (6) flat hd. screws (Y), position pinion box cover (Z) and secure with (6) hex hd. self tapping screws (AA) as shown in Fig. 10.
 - H. Grease both sides of swing arm washer and position it on swing arm anchor plate.
 - J. Apply grease to pivot contact surfaces of swing arm and insert them into swing arm anchor plate.
 - K. Secure swing arms with the appropriate hardware shown on Page 8.
 - L. Place lift adapter assy. on swing arms and secure each with (2) hex hd. bolts. 1/2" x 1" lg. and (2) 1/2" lockwashers.

Important
OPERATING INSTRUCTIONS.

The permanent operating instructions along with inspection and maintenance instruction furnished with this lift should be permanently and conspicuously displayed in the lift control area. Automotive lifts should be operated by trained personnel only. If you do not know how to position or lift a vehicle properly, do not guess. Get training. Start by reading the operating instructions, the booklet "Lifting It Right", and the "Automotive Lift Safety Tip" sheet furnished with the lift. Also refer to the vehicle manufacturer's service manuals for proper lift points and lifting procedures.

Important
HOW TO ORDER REPLACEMENT PARTS

Be sure to mention the lift model number and serial number in all correspondence dealing with service information and when ordering replacement parts. The serial number is on the top of each cylinder assembly.

Important
Underground corrosion takes place in varying degrees throughout the United States and may cause a major problem with lift equipment. To protect underground lift components, MANITOWOC LIFTS recommends that an analysis of local soil conditions be obtained, and that a knowledgeable source be consulted relative to the implementation of an adequate corrosion control system.

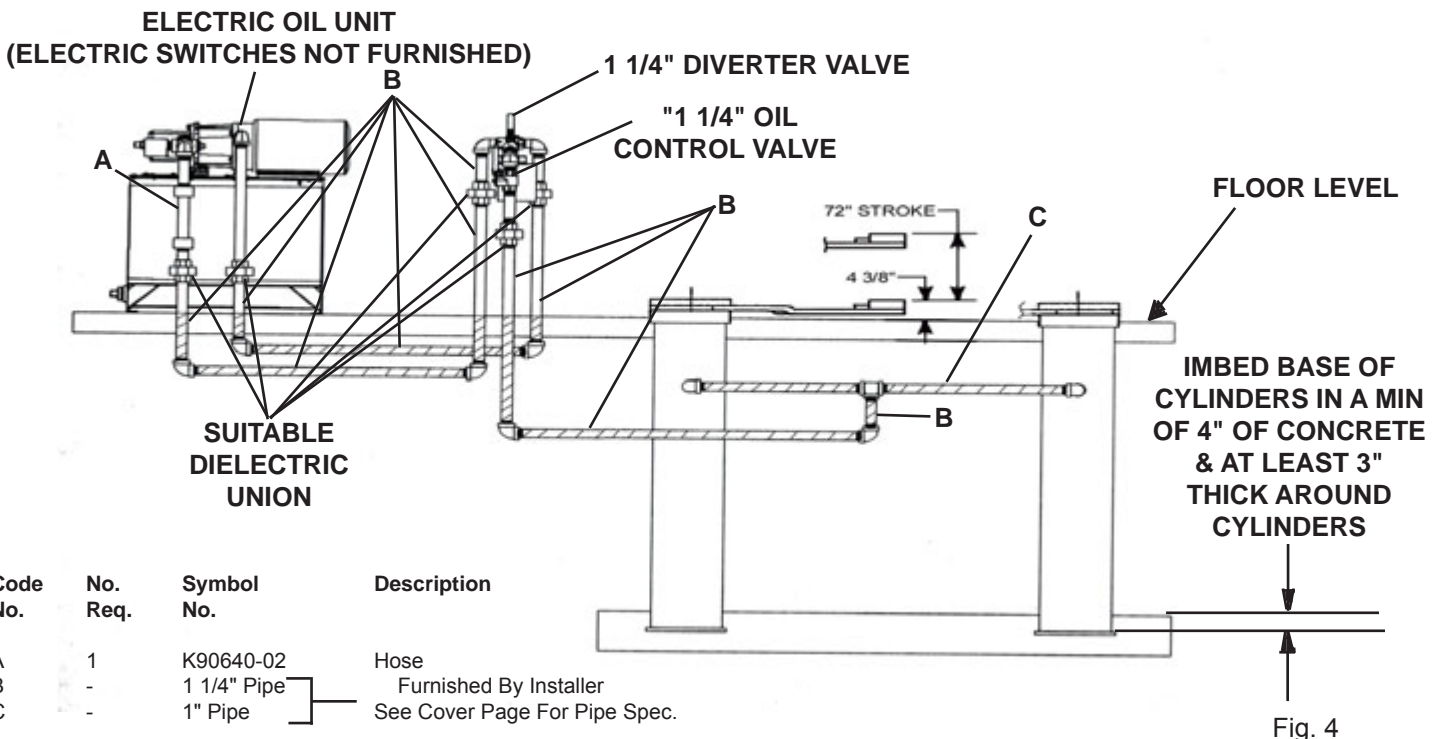

Fig. 4

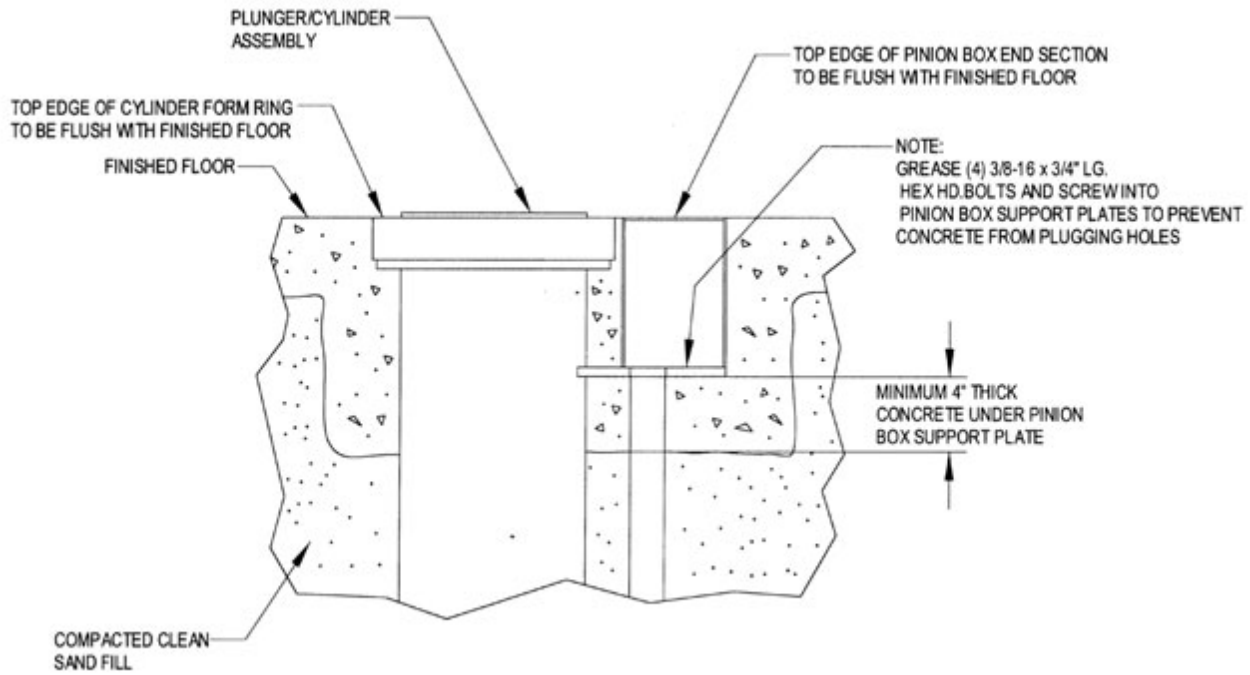

Fig. 7

INSTALLATION DETAIL - TYPICAL ON BOTH PLUNGER/CYLINDER ASSEMBLIES

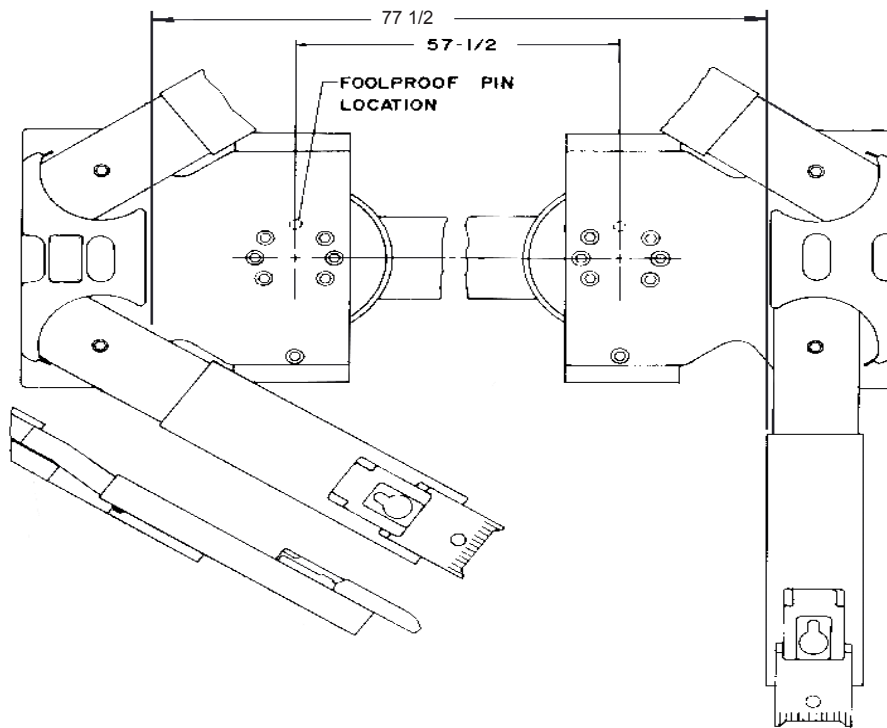

Fig. 6

SUPERSTRUCTURE BOLT HOLE PATTERN FOR A-22E5 SERIES LIFTS

INSTALLATION INSTRUCTIONS FOR ENVIROKOTE COATED LIFT COMPONENTS

The excavation must be free of any material that may damage the Envirokote Coating on the Lift Cylinder. Equipment for installing these components must be adequate to prevent damage to the coating from dragging or dropping. Similar care must be given to the coated piping. Backfill must consist of clean sand or other suitable fill that is free of organic material, rocks, debris, and other sharp objects. The backfill must be deposited carefully and completely around the buried Lift Cylinders and Piping. When tamping backfill, care must be taken to avoid damaging the Envirokote Coating.

Coated Lift Cylinders must be coated with a material compatible with the Envirokote Coating. Make all piping connections in accordance with local, state, or Federal regulations. Suitable Dielectric Unions must be used to isolate protected underground piping from unprotected above ground piping. All bracing and/or supports for unprotected above ground piping must be attached above the Dielectric Unions.

All underground piping, joints, fittings, and tie-ins to the Envirokote

TYPICAL INSTALLATION DETAIL

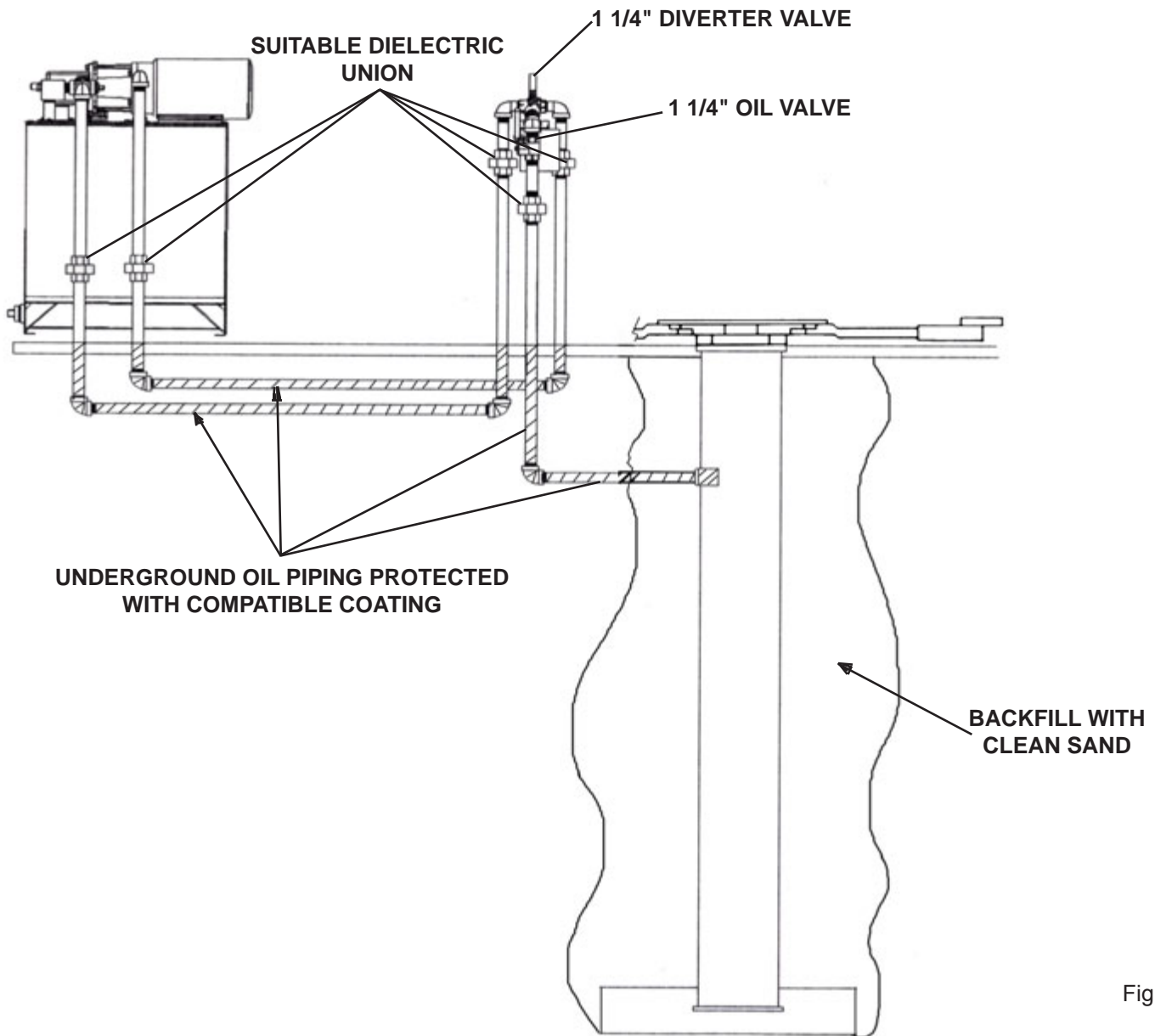
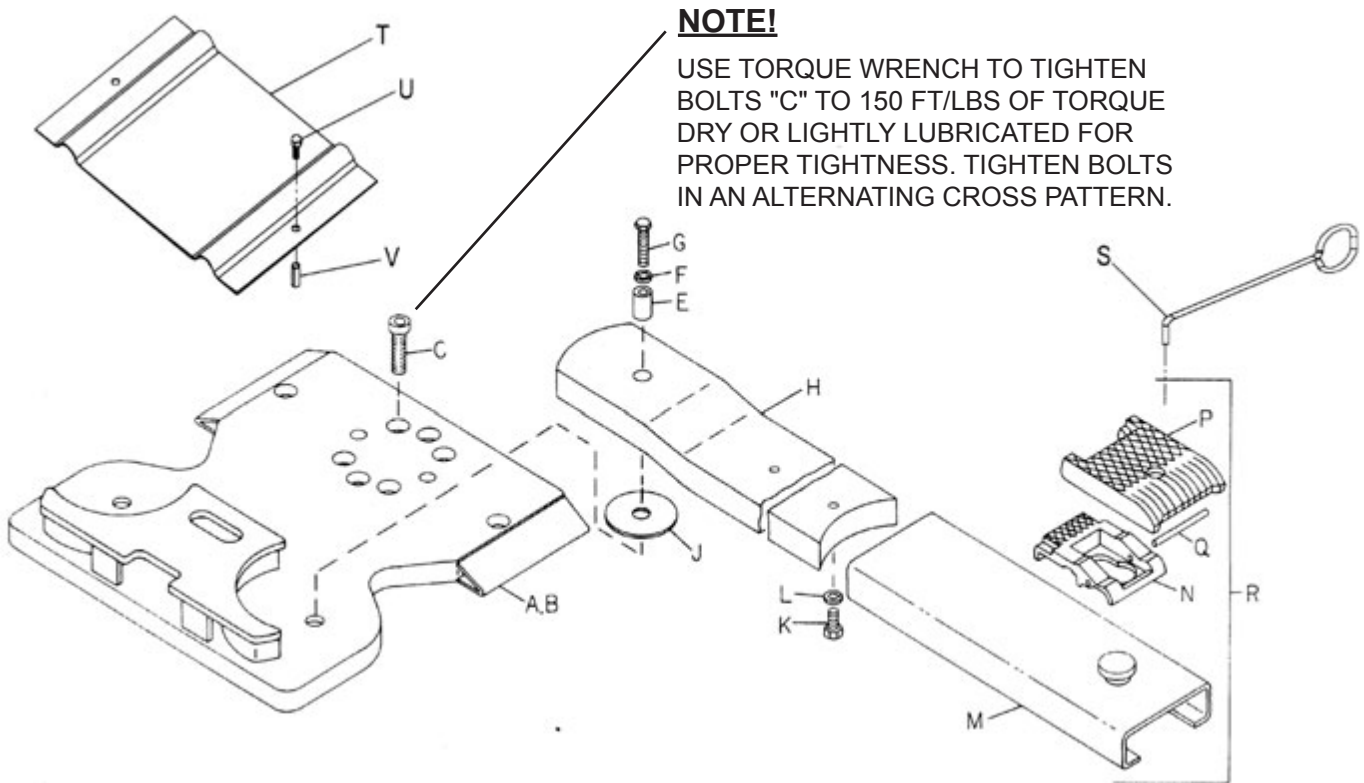

Fig. 3

When ordering replacement part, always mention lift model number and serial number.

Code No.	No. Req'd.	Symbol No.	Description
A	1	T19046-01	Swing Arm Anchor Plate
B	1	T19046-02	Swing Arm Anchor Plate W/Name Plate
* C	12	Q10035-34	Soc. Hd. Cap Screw 3/4"-10 x 2 3/4"
E	4	K85825	Pivot Swing Arm
F	4	K02215	Lockwasher 7/16"
G	4	K78272	Hex Hd. Bolt 7/16"-14 x 2 1/4"
H	4	N23116	Swing Arm
J	8	K87033	Swing Arm Washer
K	8	K01909	Hex Hd. Bolt 1/2"-13 x 1"
L	8	K02455	Lockwasher 1/2"
M	4	R19063-02	Sliding Base Assembly
N	4	R12709-02	Swivel Pad Base
P	4	R16123-02	Pickup Pad (With Protruded Ends)
Q	4	Q10038-04	Spiral Pin
R	4	N23117	Lift Adapter Assembly (Includes M, N, P, & Q) (With Protruded Ends)
S	1	K62563	Positioning Rod
T	1	T07915	Wheel Stop
U	2	K03782	Hex Hd. Bolt, 5/16"-18 x 1-3/4" Lg.
V	2	K79695	Expansion Shield

* 150,000 PSI MIN. TENSILE STRENGTH BOLT



NOTE!
IF SWING ARMS OR PICK-UP PADS ARE UNEVEN OR SAG, MORE THAN ONE ITEM "J" SWING ARM WASHER CAN BE USED TO SHIM THEIR ELEVATION AS NEEDED.

When ordering replacement parts, always mention lift model number and serial number.

Code No.	No. Req.	Symbol No.	Description
A	4	K95104	Flat Hd. Screw 1/4-20 x 5/8"
B	4	K65235-20	Flat Washer 1/4"
C	2	R13105	Pinion Box Cover - Auto Latch
D	2	N19704	Spring
E	4	Q10218-06	Hex Nut Self Locking 1/4-20
F	2	K88435	Handle
G	2	K01934	Hex Jam Nut 3/8-16
H	2	R19048	Automatic Latch
J	2	K82287-20	Set Screw Locking 1/4-20 x 5/16"
K	2	K87045	Latch Shaft
L	1	R19045	Pinion Support
L	1	R19047	Pinion Support
M	2	K95221	Warning Label

INSTALLATION

1. Raise the lift about two feet.
2. Attach the spring (D) to the underside of both pinion box covers (C) using (2) 1/4-20 x 5/8 lg. flat head screws (A), (2) self locking nuts (E) and (2) flat washers (B).
3. Screw jam nut (G) on handle (F) and then screw handle (F) into auto latch (H) until approximately 1/4 to 3/8 inch of it protrudes through the bottom of the auto latch. Lock handle (F) in position with jam nut (G).
4. Insert the completed latch assembly into both pinion supports (L) and slide latch shaft (K) through the pinion support and latch assembly. Secure it with a 1/4-20 set screw (J).
5. Attach the pinion cover and spring assembly to the pinion boxes.

OPERATION AND ADJUSTMENT

WARNING: Latch does not automatically reset after lowering except at bottom of stroke.

1. Disengage the automatic latches by pulling the handles (F) back until spring (D) engages the latch. This holds the automatic latches open and the lift can be lowered.
2. The latches are reset automatically when the lift reaches the bottom of the stroke and the superstructures contact the handles (F). If the latch does not reengage at the bottom of the stroke, it means that handle (F) does not protrude through the pinion box cover enough and must be adjusted out further until the superstructure contacts it.
3. Spring (D) should be installed to contact automatic latch (H). Latch must remain trapped behind the spring until the lift is fully lowered and the superstructure contacts the handle to reset the automatic latch.
See assembled view.

NOTE:

When adjusting the latch mechanism make sure that the handle (F) does not hit the pinion box cover when the latch is engaged. The handle must pass through the hole when the lift is settled on the latches. If the handle cannot pass through the pinion box cover hole the handle may break.

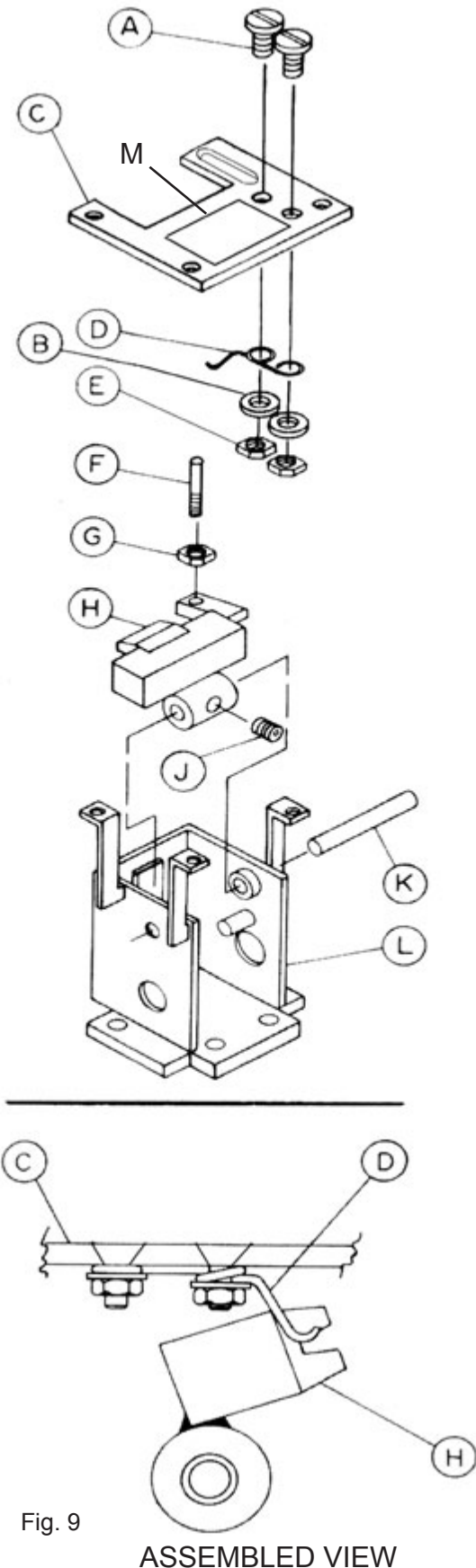
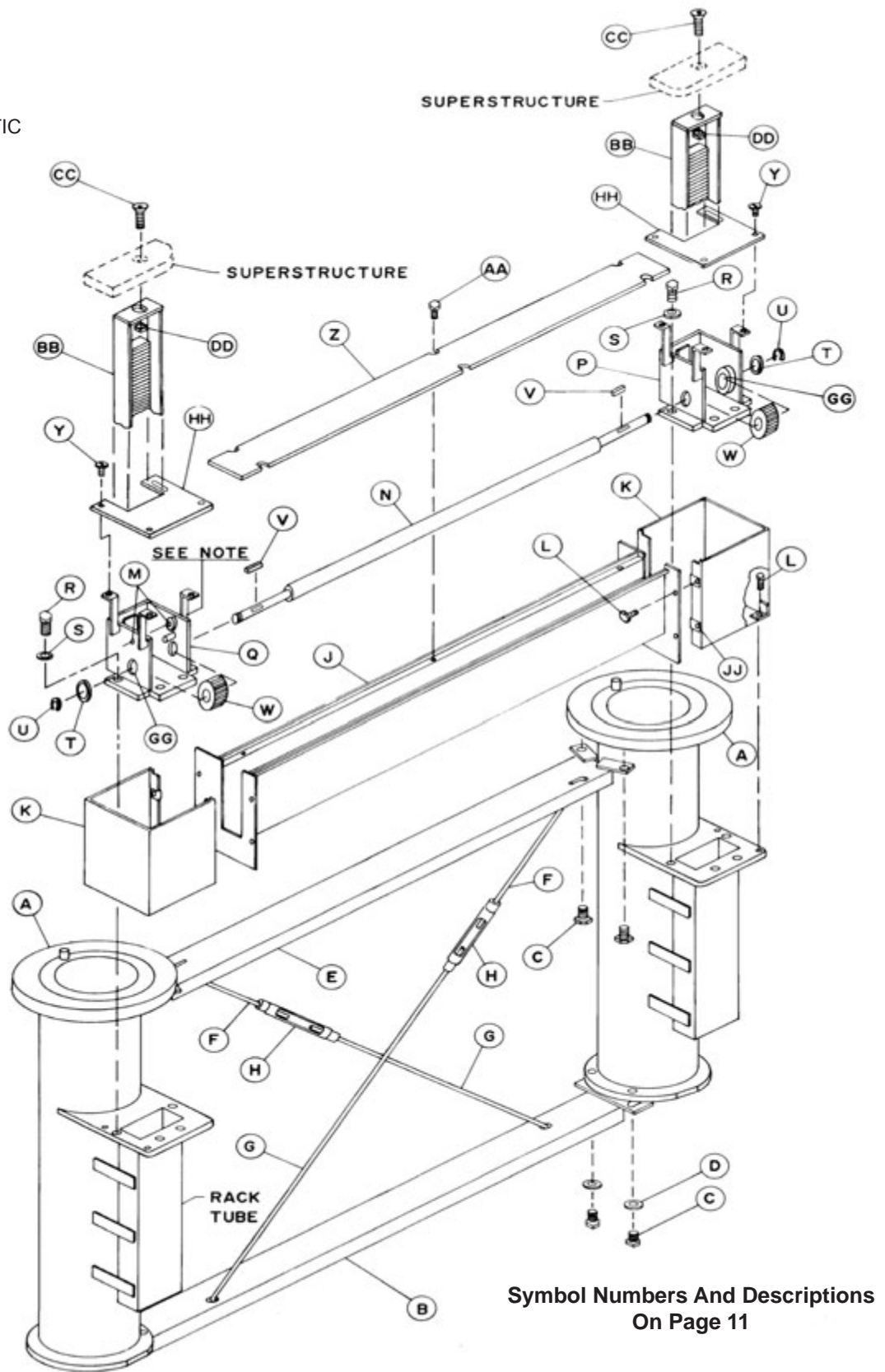

Fig. 9

ASSEMBLED VIEW

AUTOMATIC LATCH ASSEMBLY

NOTE:
SEE FIG. 9 FOR AUTOMATIC
LATCH INSTALLATION



Symbol Numbers And Descriptions
On Page 11

Fig. 10

ASSEMBLY OF: RACK AND PINION, PINION BOX, CYLINDER WITH UPPER AND LOWER BRACE

When ordering replacement parts, always mention lift model number and serial number.

Code No.	No.	Req'd.	Symbol No.	Description
A	2		T13916-08	Plunger & Cylinder Assembly (See Page 13)
B	1		R16266-02	Lower Brace
C	8		K01909	1/2"-13 x 1" Hex Hd. Bolt
D	4		K02208	1/2" Flat Washer
E	1		R16267-02	Upper Brace
F	2		N19267-02	Tie Rod-Upper
G	2		N19267-05	Tie Rod-Lower
H	2		Q10103-05	Turn Buckle
J	1		N19271-01	Pinion Box Ctr. Sect.
K	2		N19264	Pinion Box End Sect.
L	12		K05287	1/4"-20 x 1/2" Hex Hd. Bolt
M	4		K95165	Bearing (Part of P & Q)
N	1		N23080	Pinion Shaft Assy.
P	1		R19045	Pinion Support R.H. (See Page 9)
Q	1		R19047	Pinion Support L.H. (See Page 9)
R	8		Q10412-07	3/8"-16 x 1" Hex Hd. Bolt
S	8		K50775	3/8" Lockwasher
T	2		K95167	1 1/2" Flat Washer
U	2		K95170	1 1/2" Retaining Ring
V	2		K95164	3/8" Square Key
W	2		K95162	Pinion
Y	6		K95104	1/4"-20 x 5/8" Flat Hd. Screw
Z	1		R13065-01	Pinion Box Cover-Center
AA	6		K60521-24	#14 x 5/8" Hex Hd. Self Tapping Screw
BB	2		N23077	Rack Assembly
CC	2		Q10035-31	3/4"-10 x 2" Socket Hd. Cap Screw
DD	2		Q10404-01	3/4"-10 Lock Nut
GG	2		K95166	Bearing (Part of P & Q)
HH	2		R13105	Pinion Box Cover - Auto Latch
JJ	14		K81038-24	1/4"-20 Speed Nut Type "U"

Wall Control Assembly

Code No.	No. Req.	Symbol No.	Description
A	1	N23060	Diversion Valve
B	1	N23037	Oil Valve (Wall Control)
C	2	Q10849-06	1 1/4" x 90° Str Elbow
D	2	R11494-51	1 1/4" Close Nipple
E	1	K03608-24	1 1/4" x 45° Elbow
F	3	K44609	1 1/4" x 6" Nipple
G	2	K01914-59	1/4"-20 x 1 1/8" Lg. Capscrew
H	2	K02204	1/4" Dia Flat Washer
J	2	K95208	1/4"-20 Hollow-Set Anchor
K	1	N23102	Wall Bracket
L	1	K58558	U-Bolt
M	2	K01941	1/4"-20 Hex Nut
N	1	N23089	Warning Placard
O	1	A-501-30	Nylon Tie

ISOMETRIC

Existing Floor

Existing Wall

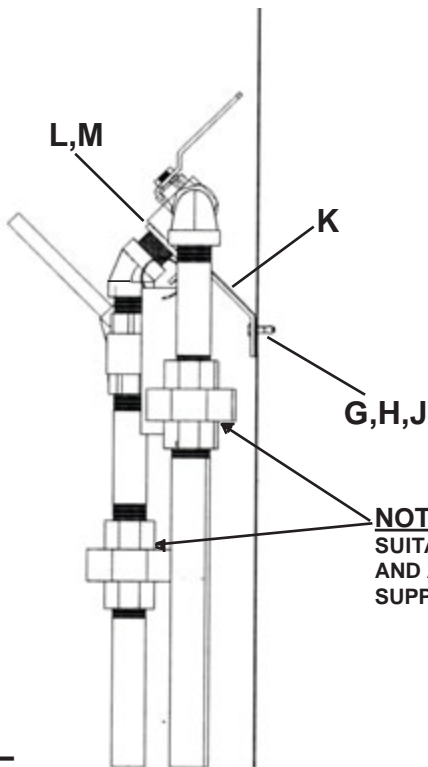
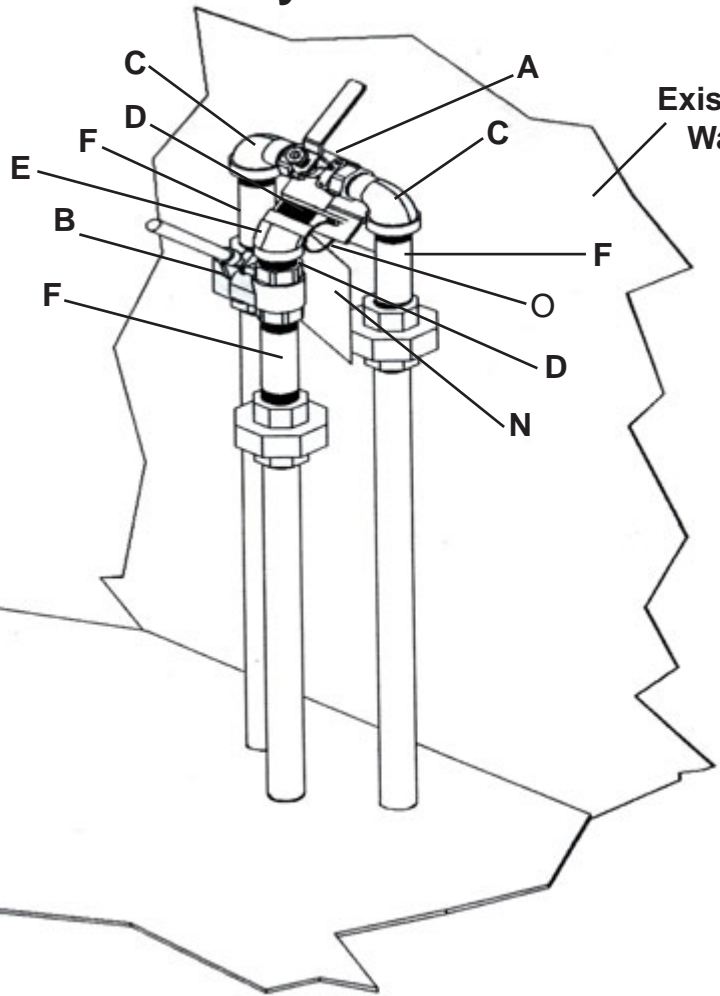

NOTE!
SUITABLE DIELECTRIC UNIONS
AND ALL PIPING BELOW UNIONS
SUPPLIED BY INSTALLER

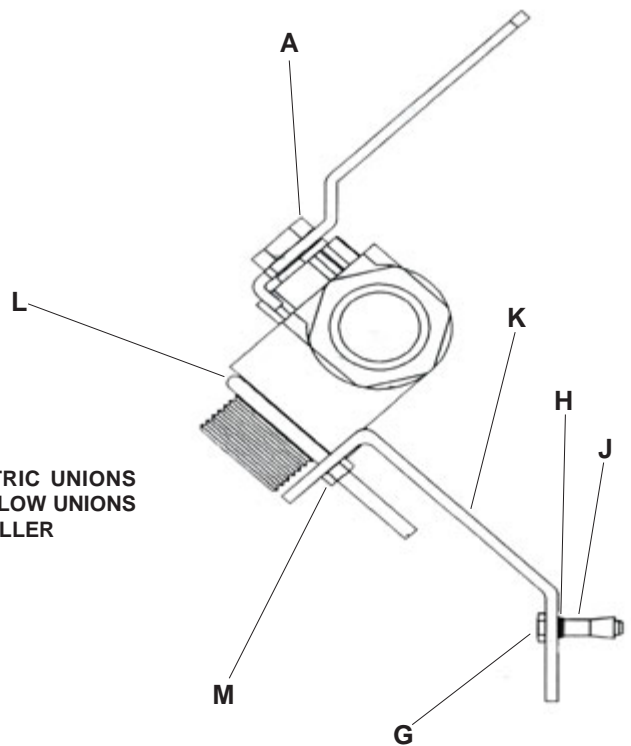

SIDE

When ordering replacement parts, always mention lift model number and serial number.

Code No.	No. Req'd.	Symbol No.	Description
	2	T13916-08	Plunger & Cylinder Assy.
A	2	T13913-G1	Cylinder Assembly
B	2	T13912-G1	Plunger Assembly
C	2	T13911-02	Upper Bearing
D	2		Felt Wiper
E	16	Q10034-82	Soc. Hd. Bolt 1/2"-13 x 2"
F	2	T13915-01	Wiper Retainer
G	12	Q10034-28	Soc. Hd. Bolt 3/8"-16 x 3/4"
H	2	N21812-G1	Air Vent
J	2		Wiper
K	2		Seal
L	2		O-Ring
M	2	K34300	Seal Kit (Includes J, K, & L)

NOTE:

WHEN ORDERING PLUNGER ASSY., SPECIFY SYMBOL NO. AND BEARING CODE LETTER STAMPED ON TOP OF PLUNGER. FOR REPLACEMENT PLUNGER ORDER KIT NO. K92930.

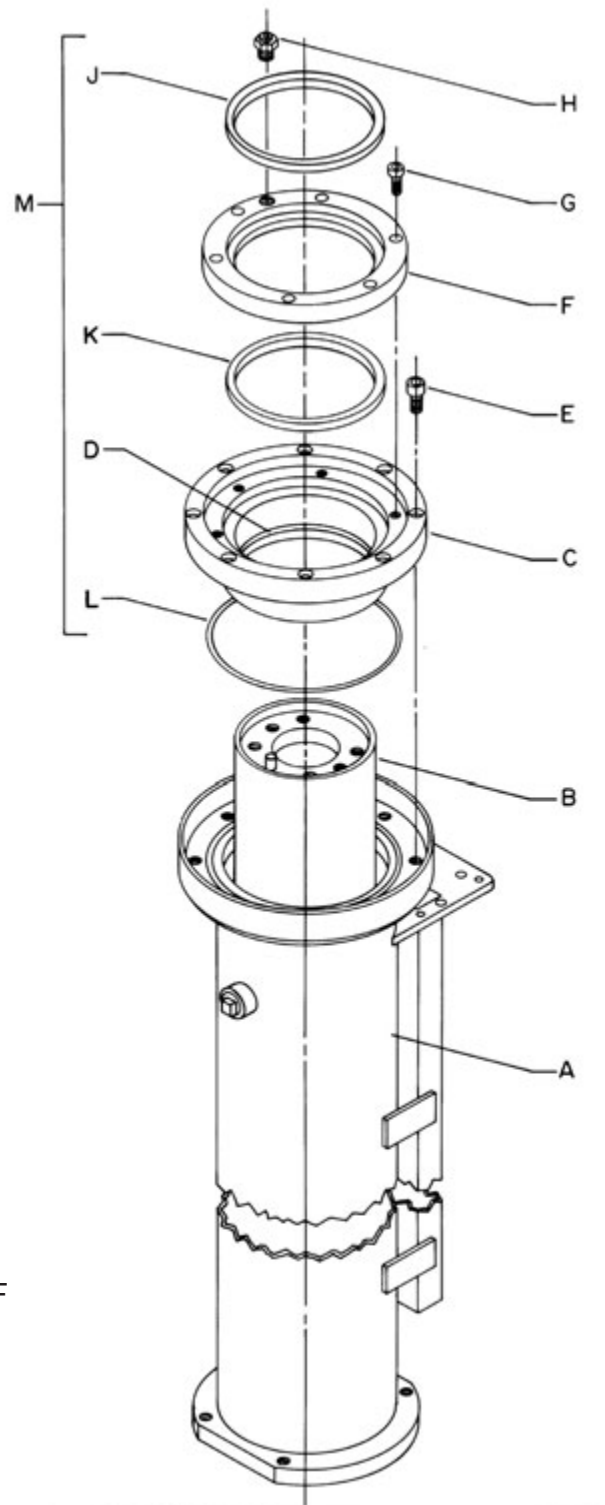

Fig. 12

NOTE!

WHEN REASSEMBLING PARTS "F" & "C" USE TORQUE WRENCH TO TIGHTEN BOLTS "E" TO 75 FT/LBS OF TORQUE DRY OR LIGHTLY LUBRICATED AND BOLTS "G" TO 21 FT/LBS OF TORQUE DRY OR LIGHTLY LUBRICATED FOR PROPER TIGHTNESS. TIGHTEN BOLTS IN AN ALTERNATING CROSS PATTERN.

PLUNGER AND CYLINDER ASSEMBLY

OIL VALVE

WHEN ORDERING REPLACEMENT PARTS, ALWAYS MENTION LIFT MODEL NUMBER AND SERIAL NUMBER.

CLOSED

OPEN

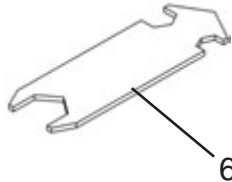
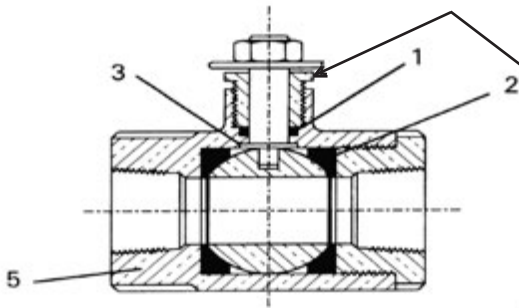
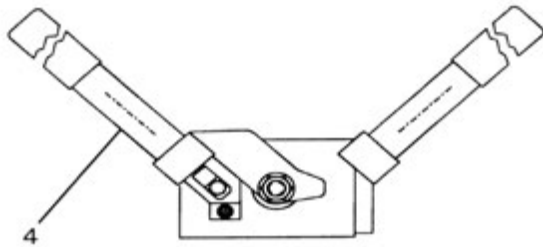

FIG. 15

WALL CONTROL VALVE

<u>ITEM</u>	<u>DESCRIPTION</u>	<u>PART #</u>
1	REBUILD KIT (INC. 1, 2, & 3)	N23037-01
4	REPLACEMENT HANDLE KIT	N23037-02
5	REPLACEMENT VALVE BODY	N23037-03
6	GLAND PACKING WRENCH	K95159

COMPLETE VALVE ASSEMBLY N23037 STEM PACKING ADJUSTMENT

Turn clockwise 1/8 to 1/4 turn when stem leaks.
DO NOT OVER TIGHTEN.
Use special wrench, item #6, provided with each lift.

Diversion Oil Control Valve

Code No.	No.	Req.	Symbol No.	Description
	1	1	N23060	Diversion Valve

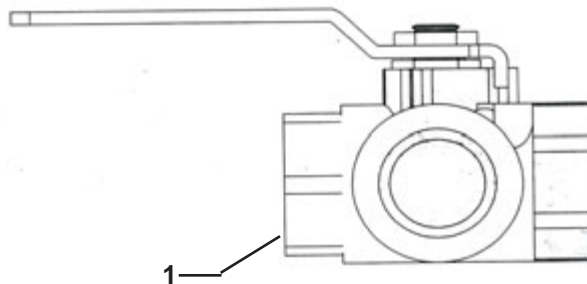
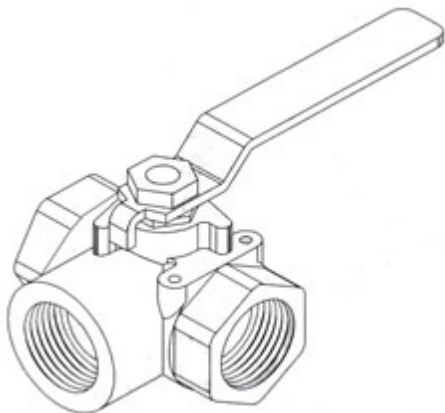

Electric Oil Power Unit

WHEN ORDERING REPLACEMENT PARTS, ALWAYS MENTION LIFT MODEL NUMBER AND SERIAL NUMBER.

Code No.				Code No.			
No.	Req.	Symbol No.	Description	No.	Req.	Symbol No.	Description
A	1	T19034-01	Tank	R	1	K95131	Suction Flange
B	1	R19040-01	Tank Cover	S	1	N23069-01	Suction Element
C	8	K60521-24	#14 x 5/8" Hex Hd. Screw	T	1	K89036	Air Breather (Twist Type)
D	1	R19041	Pump & Motor Assembly (Includes E thru M)	U	1	N20383	1-1/4" Close Nipple
E	1	K95139	Motor	V	2	R11494-51	1-1/4" Pipe Cross
F	1	K95140	Vane Pump	W	1	Q10838-06	1-1/4" Pipe Plug
G	1	K95141	Pump to Motor Adapter	X	2	K02309C02	Relief Valve Assembly
H	1	K95142	Motor Coupling	Y	1	N23070	Relief Pipe
J	1	K95143	Pump Coupling	Z	1	K95132	Tank Flange
K	1	K95144	Coupling Insert	AA	1	N21737-02	Return Pipe
L	1	K95145	Inlet Flange	BB	1	K95133	Protective Closure
M	1	K95146	Outlet Flange	CC	1	K78953-23	2" Pipe Plug
N	4	K03239	5/16"-18 x 1-1/2" Hex Hd. Scr.	DD	1	K02286	Nameplate
O	4	B-103-08	5/16" Flat Washer	EE	1	K89053	Caution Decal
P	4	B104-29	5/16" Lockwasher	FF	1	K95022	Complete Electric Oil Unit
Q	2	K47984	2" x 90° Street Elbow	GG	1	T19035-02	Dipstick Assembly
			Suction Pipe			N23099	

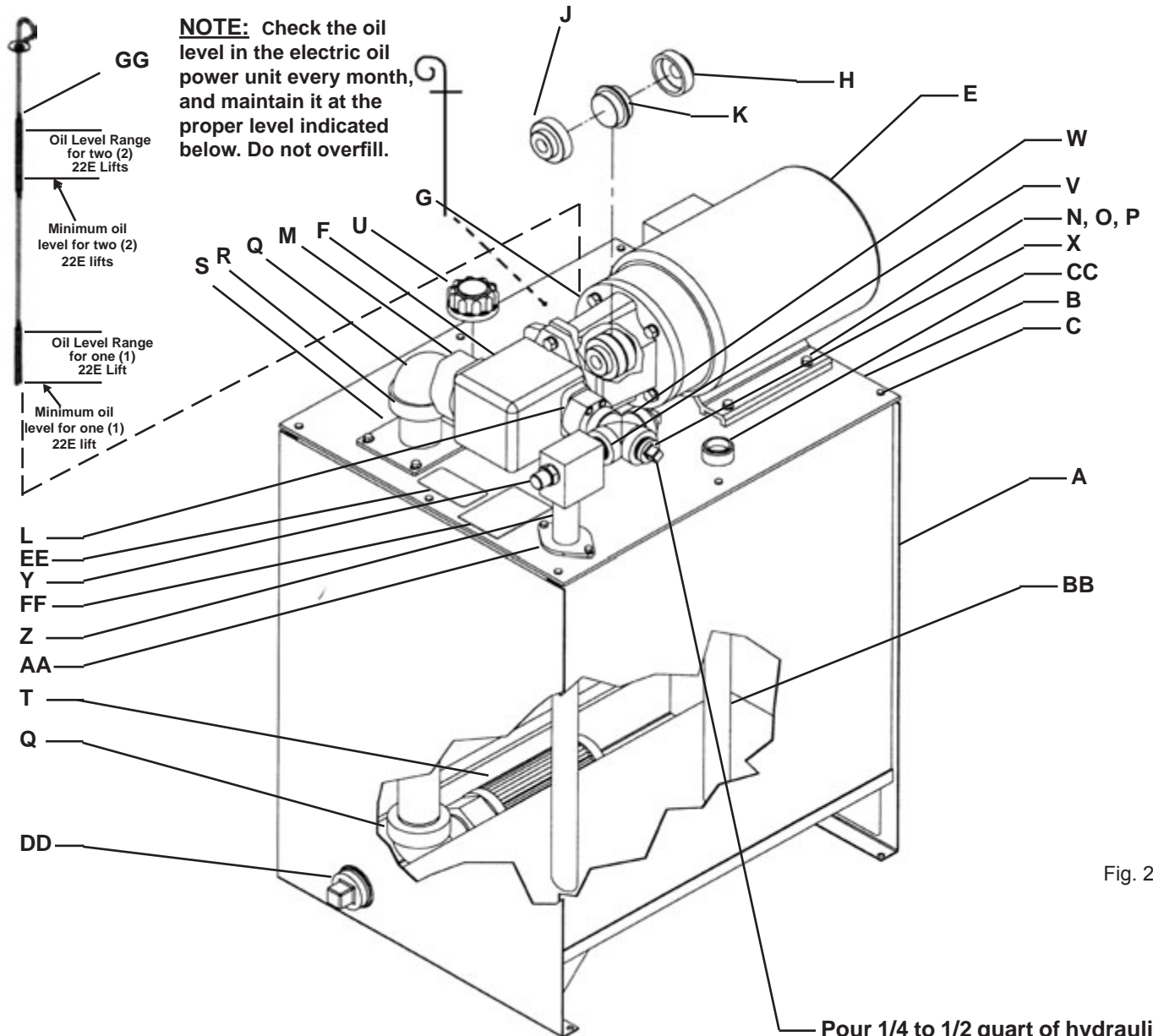

Fig. 22

Caution:
Pump rotation **MUST** be clockwise when facing pump from shaft end.

⚠ WARNING

**Lift could descend.
Always re-engage safety latches manually, every time lift is only partially lowered by pushing forward handles located on left and right side pinion box covers.**

SERIOUS INJURY OR DEATH COULD OCCUR

FRONT

This safety warning to be permanently and conspicuously displayed at lift controls, as shown

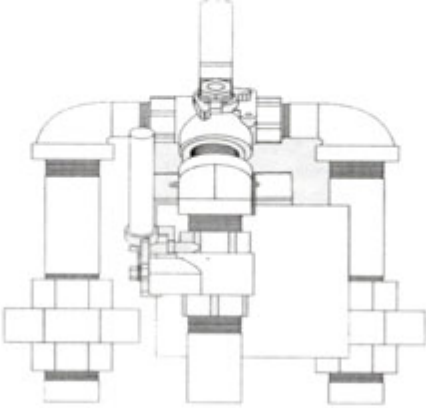

The diagram shows a top-down view of a lift control assembly. It features a central vertical shaft with a handle at the top. Below the handle are two large, symmetrical side components, likely the pinion box covers mentioned in the text. The drawing is a line-art technical illustration showing various bolts, nuts, and structural parts of the mechanism.

BACK









Fig. 16

SAFETY WARNING PLACARD

SAFETY WARNING LABELS FOR INGROUND LIFTS

Lift Owner/User Responsibilities:

- A. This Safety Warning placard **SHALL** be displayed in a conspicuous location in the lift area
- B. Use one of the mounting arrangements illustrated on back of this placard
- C. These Safety Warning labels supplement other documents supplied with the lift.
- D. Be certain all lift operators read and understand these labels, operating instructions and other safety related information supplied with the lift.

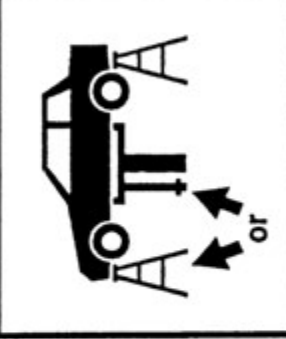
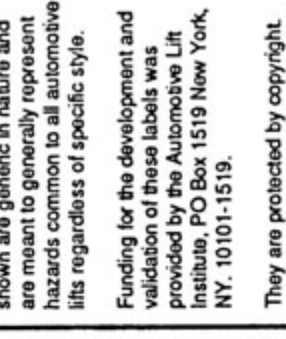
▲ WARNING 	▲ WARNING 	▲ WARNING 	▲ WARNING 	▲ WARNING 
▲ WARNING Do not override self-closing lift controls. ©	▲ WARNING DO NOT remove oil fill plug before reading manufacturer's manuals. ©	▲ WARNING Position vehicle center of gravity over lift. ©	▲ WARNING Remain clear of lift when raising or lowering vehicle. ©	▲ WARNING Keep feet clear of lift while lowering. ©
▲ WARNING 	▲ WARNING 	▲ WARNING 	▲ WARNING 	▲ WARNING 
▲ WARNING Clear area if vehicle is in danger of falling. ©	▲ WARNING Avoid excessive rocking of vehicle while on lift. ©	▲ WARNING Chock wheel to prevent vehicle movement. ©	▲ WARNING Use lift locking device or 4 stands to support vehicle. ©	▲ WARNING Use lift locking device or 4 stands to support vehicle. ©

The messages and pictographs shown are generic in nature and are meant to generally represent hazards common to all automotive lifts regardless of specific style.

Funding for the development and validation of these labels was provided by the Automotive Lift Institute, PO Box 1519 New York, NY. 10101-1519.

They are protected by copyright. Set of labels may be obtained from ALL or its member companies.

SAFETY WARNING LABELS

TYPICAL PLACARD LOCATIONS

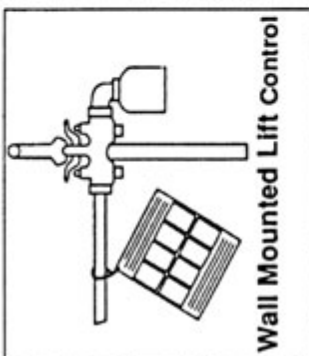
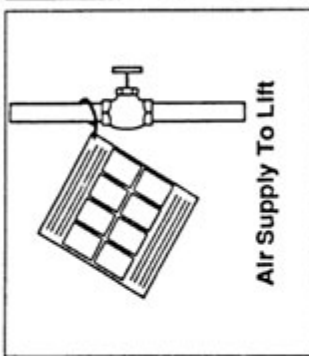
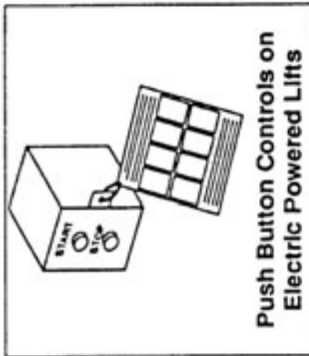
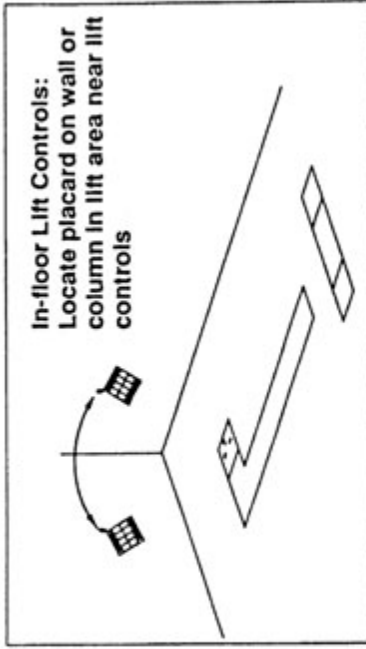

▲ CAUTION

Use height extenders when necessary to ensure good contact. ©

▲ CAUTION

Always use safety stands when removing or installing heavy components. ©

▲ CAUTION

Use vehicle manufacturer's lift points. ©

▲ CAUTION

Authorized personnel only in lift area. ©

▲ CAUTION

Lift to be used by trained operator only. ©

▲ CAUTION

The messages and pictographs shown are generic in nature and are meant to generally represent hazards common to all automotive lifts regardless of specific style.

Funding for the development and validation of these labels was provided by the Automotive Lift Institute, PO Box 1519 New York, NY, 10101-1519.

They are protected by copyright. Set of labels may be obtained from ALI or its member companies.

© 1992 by ALI, Inc. ALLIWL500c4

SAFETY INSTRUCTIONS

Do not operate a damaged lift. ©

SAFETY INSTRUCTIONS

Proper maintenance and inspection is necessary for safe operation. ©

SAFETY INSTRUCTIONS

Read operating and safety manuals before using lift. ©

▲ CAUTION

Auxiliary adapters may reduce load capacity. ©

SAFETY WARNING LABELS



MANITOWOC LIFTS

www.manitowoclifts.com

www.sviinternational.com

(800) 321-8173 • fax: (800) 899-1784

Main Office: 155 Harvestore Drive • DeKalb, IL