

# MANITOWOC LIFTS

## INSTALLATION INSTRUCTIONS AND PARTS LIST "SWING-RAIL" TWO-POST FULL HYDRAULIC LIFTS DRIVE-THRU A-12D3A SERIES DRIVE-THRU "575" A-12E3A TWO-POST FULL HYDRAULIC ALIGNMENT LIFTS A-12L3A & A-12N3A SERIES (8000LB. CAPACITY)

### Recommendations

**AIR EXHAUST:** Pipe air exhaust outside building when possible or install the MANITOWOC LIFTS silencer furnished with this lift. This eliminates noise and provides a much more satisfactory installation.

**PIPING:** Use only new pipe. See that threads are perfect. Before using the pipe, hammer it to loosen all scale, spelter, and dirt, then wash the interior with kerosene. The pipe should pitch up gradually from the cylinder to the control valve with no traps or low places. Use pipe sealing compound on the male threads of all screw connections, unless your local authorities require the use of some special material. Do not use on the female thread. Verify that all pipe joints are tight, with no leaks prior to backfill and pouring of concrete.

**COMPRESSOR:** The compressor should be of the two stage type. Operating pressure to be 112 psi. **An air pressure relief valve, set to limit the air supply to no more than 134 psi must be installed.** Air pressure and tank storage size are important as they determine the lifting speed and capacity of the lift.

**All piping, fittings, and valves must have a rated burst pressure of not less than 402 psi (Three times the Maximum Operating Pressure). Do not use plastic piping, fittings or valves.**

**INSTALLATION MUST BE MADE IN ACCORDANCE WITH LOCAL, STATE AND FEDERAL REGULATIONS AND IN STRICT CONFORMANCE WITH THESE INSTRUCTIONS.**

**USE ONLY MANITOWOC LIFTS AUTHORIZED REPLACEMENT PARTS**

#### - Warning -

This lift is designed for indoor use only! Outdoor installation will void the warranty.

- Do not pressurize system with shipping strap in place! Do not operate until system is properly filled with oil  
-The plunger top plates have foolproof pins which must be kept in line with the oil inlet coupling(180 deg. from the rack tube). The plunger should not be rotated in the cylinder. If the plunger is removed, it must be oriented as stated above when put back in the cylinder.

#### - Caution -

If lift will not be installed within one week fill plunger-cylinder assemblies with SAE 10 hydraulic oil. After the plunger assembly is installed and piping has been completed, fill the system with oil to protect the plunger from corrosion until the facility is opened. Do not raise plunger until oil has been added.

**THESE INSTRUCTIONS MUST BE THOROUGHLY READ AND FOLLOWED BY INSTALLER DURING INSTALLATION, AND THEN BY THE USER THROUGHOUT THE LIFE OF THE LIFT. THESE INSTRUCTIONS MUST ALSO BE THOROUGHLY READ AND FOLLOWED BY THE AUTHORIZED SERVICE CONTRACTOR DOING SERVICE WORK ON THE LIFT TO ASSURE PROPER ASSEMBLY OR DISASSEMBLY.**

**FOR PROBLEMS OR QUESTIONS WITH THE INSTALLATION, CALL TOLL FREE: 800-321-8173**



**SVI International, Inc.**  
Manitowoc Lifts - An SVI Brand Product Line  
(800) 321-8173 • 155 Harvestore Drive, DeKalb, IL  
[www.manitowocliffts.com](http://www.manitowocliffts.com) • [www.sviinternational.com](http://www.sviinternational.com)

# GENERAL INFORMATION/FLOOR CONDITIONS

MANITOWOC LIFTS products are designed to give many years of trouble free operation if installed correctly and given proper care.

This lift operates on the full hydraulic principle which means that the load and lifting assembly are at times supported on a continuous column of oil which extends from the cylinder to the oil valve.

The low oil control valve is located in the oil reservoir tank. This valve stops the operation of the lift when oil level drops to a minimum safe level. Operation of lifts without sufficient oil can be hazardous and damaging to the lift.

MANITOWOC LIFTS will not assume any responsibility or liability, financial, legal or otherwise, in connection with the installation of its lifts which goes beyond the stated limitations of the standard instruction sheet or drawings currently applying at the date of shipment, to individual models of MANITOWOC LIFTS.

In the event MANITOWOC LIFTS representatives consult with contractors, owners, or their employees regarding location

Determine what floor conditions exist or will exist where the lift is to be installed.

**FLOOR SLOPE** - 1/8" per ft. drainage slope away from lift recommended. Floor slope must provide sufficient clearance so that swing rails are free to move with lift in "Down" position.

**HEADROOM** above lift. Provide ceiling clearance for your highest vehicle when the lift is raised.

The sketches below show two types of installation: -one showing a lift perpendicular or parallel to a wall, and the other, a lift at an angle to a wall. (The latter used when sufficient approach space is not available.)

Note recommended 3 ft. minimum clearance aisle and space for a work bench provided in front of car. (Fig. 1B).

Note clearance required on either side of car of opening doors.

When two or more lifts are installed adjacent to one another, they should be set with a recommended distance of 12 ft. between center lines of lifts. It is possible to located adjacent lifts 10 ft. apart, but this spacing should be used only when absolutely necessary.

Location of the lift control valve is optional to some extent and must be determined to best suit the installation. Controls should be located to give the operator a clear unobstructed view of the lift.

1. **LOCATING THE LIFT:** Proper location of a lift is essential to insure efficient usage and operation. Therefore a careful study should be made of the area available for installation.

CONSIDER:  
DIRECTION OF TRAFFIC FLOW

APPROACH SPACE to allow adequate maneuver ability of the car.

WORKING AREA required around car.

## IMPORTANT

2. Inspect cylinders for shipping damage and check drain plug for tightness before cylinder assembly is installed.

**NOTE:** Dimensions indicated in sketches are recommended minimum only.

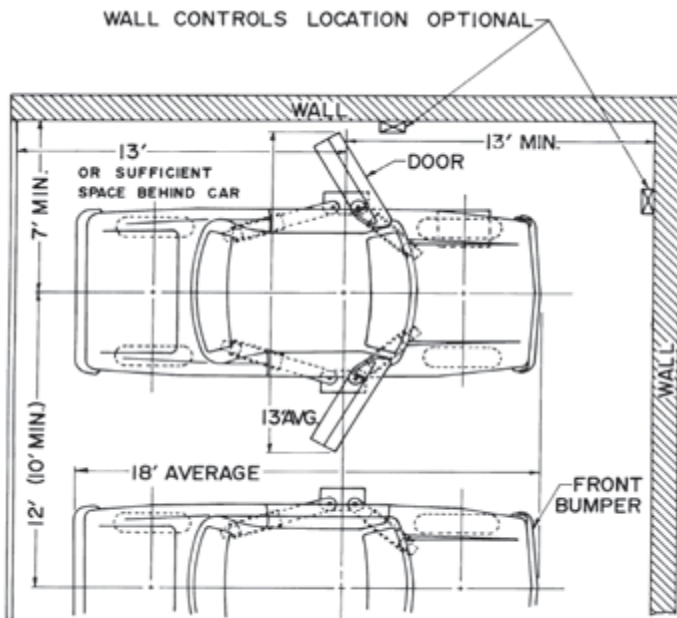

FIG. 1A

T0932I

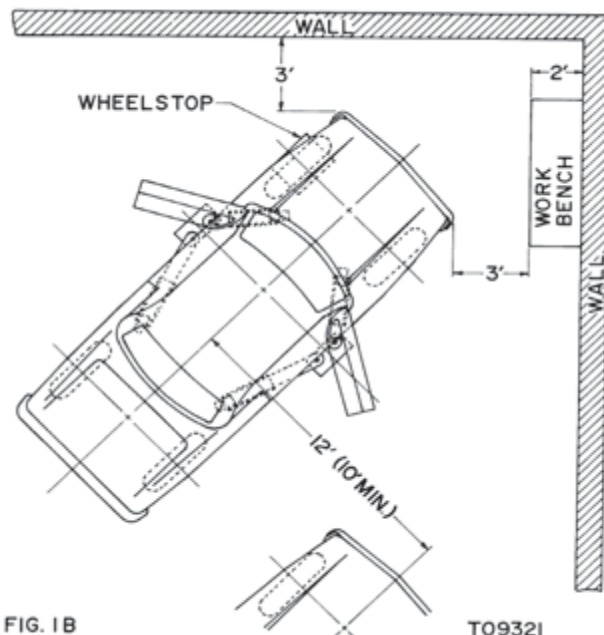

FIG. 1B

T0932I

- Determine lift location and provide proper working space and clearance as outlined in previous section "Locating the Lift." After determining lift location, excavate a hole, centered on this position to receive the two-post plunger-cylinder assembly

with racks, pinions, and housings assembled. Dimensions of this excavation are shown in Fig. 2. Pour concrete slab in the bottom of the plunger-cylinder excavation. The approximate dimensions of this slab are shown in Fig. 2.

## INSTALLATION INSTRUCTIONS

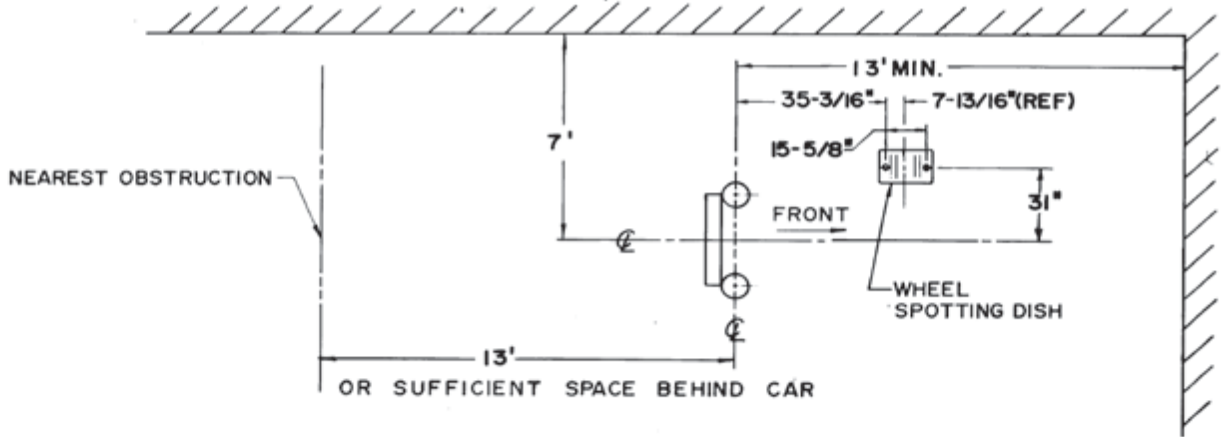

LOCATION OF LIFT

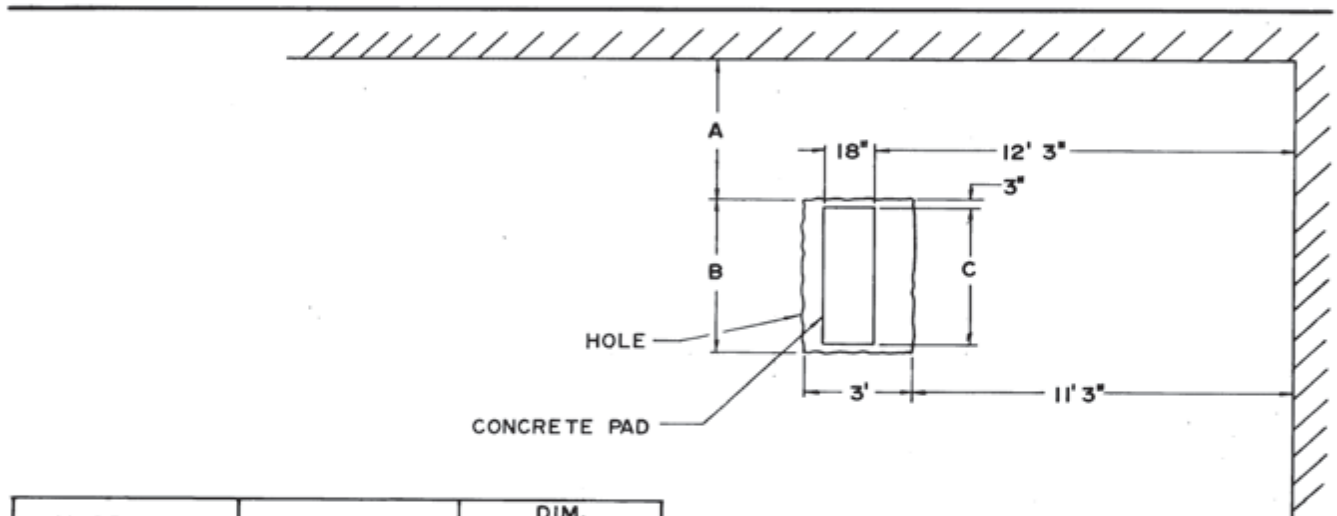

MODEL NO.	TYPE	DIM.		
		A	B	C
A-12D SERIES	DRIVE THRU	2'-3"	9'-6"	9'-0"
A-12L SERIES	ALIGNMENT			
A-12E SERIES	DRIVE THRU 575	3'-7"	6'-10"	6'-4"
A-12N SERIES	ALIGNMENT			

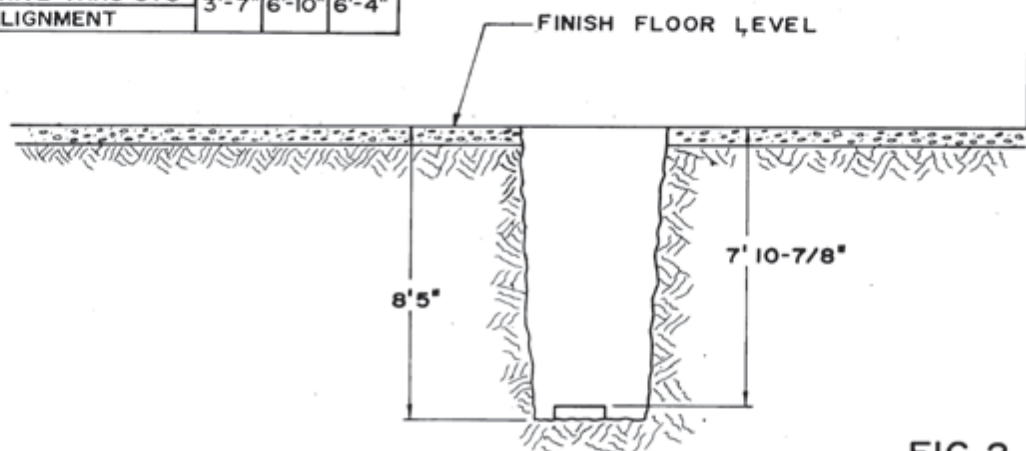

RI6280

FIG. 2

LOCATION OF HOLE

# INSTALLATION INSTRUCTIONS FOR ENVIROKOTE LIFT COMPONENTS

The excavation must be free of any material that may damage the Envirokote Coating on the Lift Cylinder and Air/Oil Tank. Equipment for installing these components must be adequate to prevent damage to the coating from dragging or dropping. Similar care must be given to the coated piping. Backfill must consist of clean sand or other suitable fill that is free of organic material, rocks, debris, and other sharp objects. The backfill must be deposited carefully and completely around the buried Air/Oil Tank, Lift Cylinder and Piping. When tamping backfill, care must be taken to avoid damaging the Envirokote Coating.

All underground piping, joints, fittings, and tie-ins to the Envirokote

Coated Lift Cylinders and Air/Oil Tanks must be coated with a material compatible with the Envirokote Coating. Make all piping connections in accordance with local, state, or Federal regulations. Suitable Dielectric Unions must be used to isolate protected underground piping from unprotected above ground piping. All bracing and/or supports for unprotected above ground piping must be attached above the Dielectric Unions.

## TYPICAL INSTALLATION DETAIL

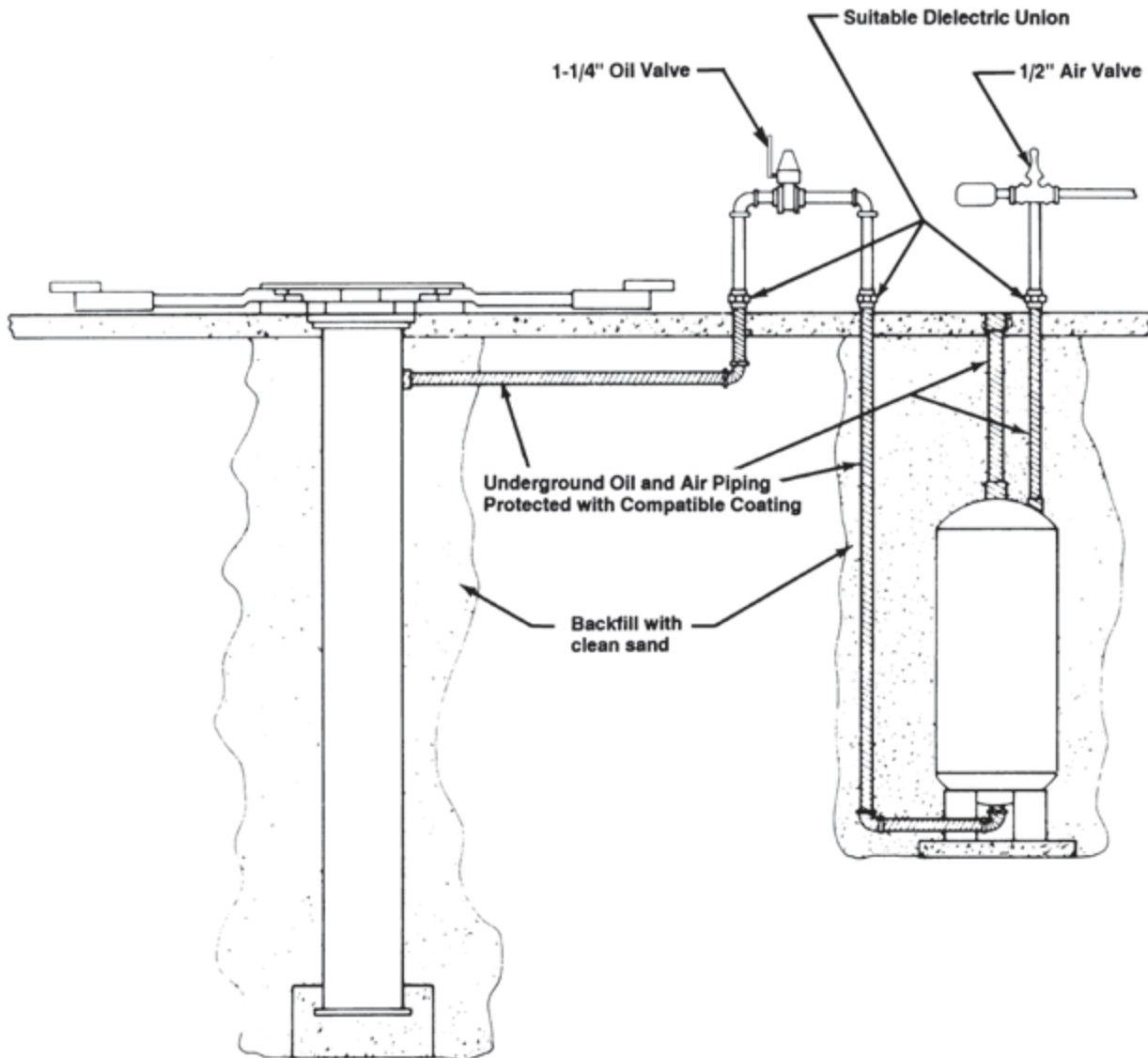

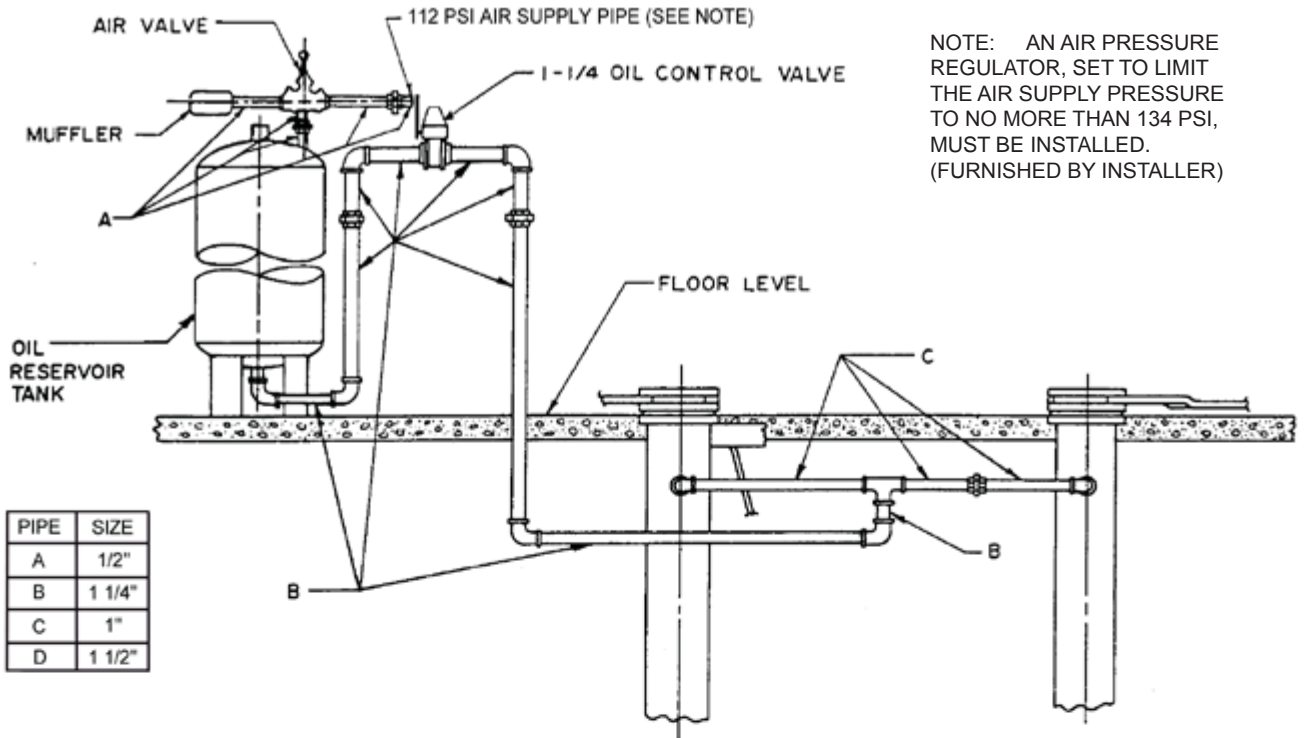

PIPE	SIZE
A	1/2"
B	1 1/4"
C	1"
D	1 1/2"

INSTALLATION OF OIL TANK ABOVE GROUND

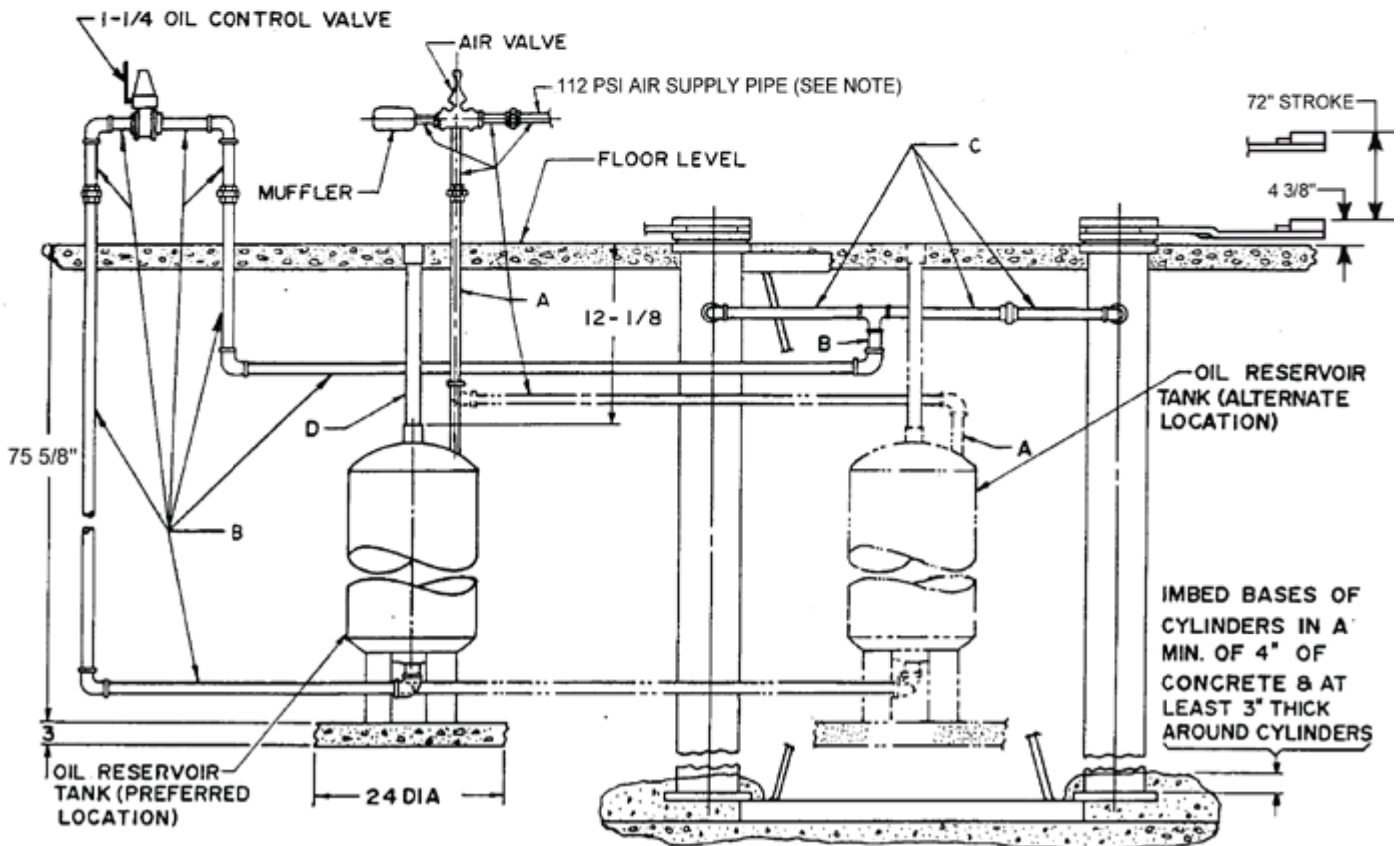

RI6279

INSTALLATION OF OIL TANK BELOW GROUND

FIG. 3

4. ASSEMBLING PLUNGER-CYLINDER (See Fig. 12)
  - A. Position the (2) plunger-cylinder assemblies (A) on wooden horses or equivalent. make sure that the horses are level and the rack tubes on the plunger-cylinder assemblies are facing up.
  - B. Fasten the top of the plunger-cylinder assemblies together by bolting the upper brace (E) to the cylinder bolt ring using (4) hex hd. bolts (C). Fasten the bottom of the plunger-cylinder assemblies together by bolting the lower brace (B) to the cylinder bottom plate using (4) hex hd. bolts (C) and (4) washers (D). These (8) hex. hd. bolts (C) should be snug but yet allow some movement for alignment.
  - C. Install the (2) tie rods ( F&G) criss-cross to the plunger-cylinder assemblies (A) with the turn buckles (H) toward the top.
  - D. On A-12D & A-12L models only, install tie rod (EE) between upper brace (E) and lower brace (B) and secure with hex. nuts (FF). Do not tighten nuts more than finger tight.
  - E. Adjust the entire assembly to the center-to-center dimensions and diagonal dimensions as shown in Fig. 4. These dimensions vary depending on the model lift being installed.
  - F. With plunger-cylinder assemblies aligned, wrench hex. hd. bolts(C), that hold upper and lower braces, full tight.
  - G. Fasten (2) pinion box end sections (K) to top of rack tube using (4) hex. hd. bolts (L).
  - H. Fasten pinion box center section (J) to end sections of box using (8) speed nuts (JJ) and (8) hex. hd. bolts (L).
  - J. Insert Woodruff keys (V) into slots in pinion shaft (N). Using a light lubricating oil, lube pinion shaft (N) ends and pinion supports (P&Q) brass sleeve bearings.
  - K. While holding the pinion gear (W) in the R.H. pinion support (P), insert the pinion shaft (N) thru the clearance hold in the pinion support; thru the pinion gear (W) and in thru the bearing on the far side of he pinion support.
  - L. Secure the end of the pinion shaft on the outside of the pinion support using washer (T) and retaining ring (U).
  - M. Repeat steps "K" and "L" for L.H. end of pinion shaft using pinion support (Q).
  - N. INSTALL AUTOMATIC LATCH as shown in Fig. 11.
  - O. Using (8) hex. hd. bolts (R) and (8) washers (S), fasten the complete assembly made above to the plates on top of the rack tubes. Snug The Bolts But Do Not Tighten Them.
  - P. Slide the (2) racks (BB) into the pinion supports so that tooth engagement is equal to each other.
5. POSITIONING PLUNGER-CYLINDER IN EXCAVATION. Using a 2000 pound capacity chain hoist with at least 9'-0" clear swing, lower the plunger-cylinder assembly into excavation. NOTE: Rack and pinion assembly of the lift is to be located on the same side as the direction of approach of vehicle. A rope sling around each of the plunger-cylinder assemblies is recommended. **CAUTION:** Do not lift the plunger-cylinder assembly into excavation from the center of the upper or lower braces. After plunger-cylinders have been positioned in excavation and temporarily blocked, shim under lower brace (B) to bring the top of the concrete ring (around cylinder bolt ring) flush with the final floor grade. Using a spirit level, as shown in

Fig. 4, adjust each plunger-cylinder to be plumb and parallel to each other. It may be necessary to make minor adjustments to the tie rods to obtain these conditions. This operation is very important for a satisfactory Installation. Block assemblies securely after final level and plumb adjustments.

6. COMPLETE PIPING as shown in Fig. 3. Location of oil reservoir tank is optional, however, we strongly recommend that the installation of the tank below ground level be considered first choice if local ordinances permit. Fig. 3 illustrates the oil reservoir tank installation. For below ground installation, the tank may be located in the excavation between the plunger-cylinder assemblies or adjacent to the wall, whichever is more convenient for a given installation. Attention is directed to the correct dimensional relation of the oil reservoir tank to the floor grade level in order to maintain correct relationship to the oil level dip stick within the tank. Install extension on oil fill opening so tank may be filled and gauged at floor level. Install oil control valve with inlet and outlet ports horizontal and handle oriented vertically upward. Spring loaded handle can be pulled toward

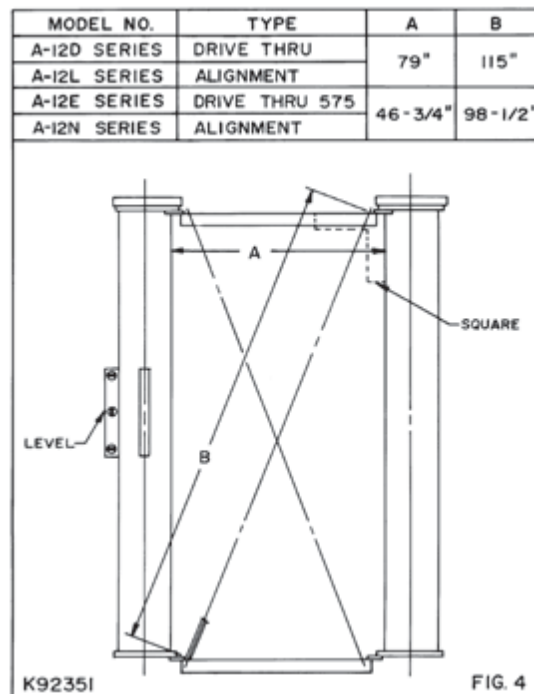

the operator to activate the lift. Piping arrangement applies for either above or below ground installations.

7. FILL SYSTEM WITH OIL. The oil capacity requirements are approximately 60 gallons. Use only hydraulic lift oils recommended by petroleum manufacturers for use in hydraulic lifts. Viscosity rating should be approximately 100-125 SSU at 100°F. Most SAE 10 oils (new) are acceptable. Avoid oils which foam under air pressure. A rust inhibitive oil is strongly recommended. **WARNING** - Do not pressurize system with shipping strap in place! Do no operate until system is properly filled with oil! Follow the steps given below, keeping in mind that the system must be filled and bled gradually.
  - Remove Shipping Strap, discard it and the 3/8" bolts and lockwashers.
    - A. Place Air Control handle in exhaust position. Remove oil gauge from oil fill pipe.
    - B. **CAUTION** - Always place air control valve in exhaust
    - C. position before removing oil gauge.

- D. Loosen air vent plug (located in top cylinder casting.)
- E. Fill tank to the full level on the oil gauge.
- F. Remove Float Assembly from the loose parts kit and insert through tank fill opening with the hook end up. Check float to be certain it is free and floating. (Ref. Fig. 5).

**WARNING: OPERATION OF THE LIFT WITHOUT THE FLOAT COULD RESULT IN DAMAGE TO THE LIFT OR A SAFETY HAZARD SHOULD A LOW OIL CONDITION OCCUR.**

Float Guide and Oil Gauge Assembly are installed in tank at factory. The Float Assembly, which is packaged in the loose parts package, must be installed during lift installation.

**Caution:**

If for any reason the length of the fill pipe is changed, the length of the oil gauge assembly must also be increased or decreased by exactly the same amount. The disc must be reattached if it is removed to change dip stick length.

**INSTALLING LOW OIL CONTROL AND OIL GAUGE ASSEMBLY**

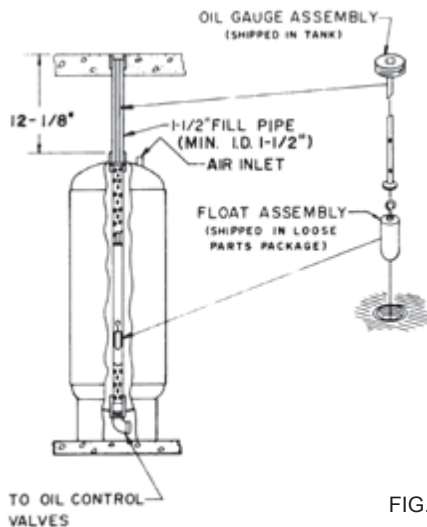

FIG. 5

- G. Replace oil gauge and move air control valve handle to "Raise" or supply position.
  - H. Bleed air from cylinders by gradually admitting oil to cylinders by means of the oil control valves. Air will escape from air vents. When a steady stream of oil flows freely from air vent holes, close oil control valves and tighten air vent plugs. Raise plungers no more than 3 ft. Close oil control valves. Apply soapy water to all air pipe joints and observe for leaks. Also observe all oil joints for leaks. Place air control valve in exhaust position and open oil control valves until plungers are completely lowered. Check oil level in tank using the oil gauge. Add sufficient oil in tank to bring the oil level up to the hole in oil gauge. Replace oil gauge. Repeat bleed and refill procedure until no air escapes from air vents.
  - K. Repeat bleed and refill procedure until no air escapes from air vents.
8. IMBED BASES OF CYLINDER IN 4" MIN. OF CONCRETE & AT LEAST 3" THICK AROUND CYLINDER. See Figure 3.
  9. BACK FILLING. The excavation should be back filled with clean sand one foot at a time followed by solid tamping. Do not use cinders or other corrosive fill material.

**CAUTION:** Do not force the plunger-cylinder assemblies if they should be out of plumb, but remove sand and re-plumb the units.

**CAUTION:** Do not allow dirt to enter rack and pinion area during back filling.

10. COMPLETE BACK FILLING AND FINAL POURING OF CONCRETE FLOOR. Pour concrete floor. Protect the rack and pinion from concrete. Grease (4) 3/8-16 x 3/4 lg. hex hd. bolts and screw into pinion box support plates to prevent concrete from plugging holes. Be sure to pour concrete under pinion box support plates. See Fig. 6. Do not allow concrete to splash or pour into housings. Allow concrete to cure at least 24 hours.

**BALLAST SHOULD BE PROVIDED FOR BOTH PLUNGERS.**

11. This may be accomplished by filling the hollow of the plungers with a mixture of clean oil and sand, (no foundry sand), is recommended. Care should be taken not to let sand get into the packing area by providing a funnel of some type.

**12. ASSEMBLING OF SUPERSTRUCTURE. (FIG. 7 thru 10).**

- A. Refer to Figure 7 or 8 depending on which model lift is being installed. Figs. 9 & 10 are for models A-12L and A-12N and only show the mounting hole pattern since MANITOWOC LIFTS does not supply the superstructure for these lifts.
- B. On Series A-12D3A and A-12E3A lifts only, position the swing arm anchor plate on the plunger, by first locating the "Foolproof Pin" opposite the rack tube. Bolt swing arm anchor plate to top of plunger with the appropriate hardware shown for your particular lift. These bolts have a minimum tensile strength of 150,000 PSI.
- C. Place the pinion box end covers (HH) over the rack assembly. (Do not bolt in place yet.)
- D. Fasten the swing arm anchor plate to rack assy. (BB) using screw (CC) and locking nut (DD) as shown in Fig. 12.
 

**CAUTION** - Be sure that the screw goes completely through the jam nut and protrudes out the other side in order to prevent the nut from backing off. Do not wrench the locking nut full tight. Allow movement between the rack and swing arm anchor plate.
- E. Cycle lift once or twice to allow rack assy. to properly position both pinion supports.
- F. Tighten mounting bolts (R) for both the pinion supports now.
- G. Lubricate rack teeth with a light grease.
- H. Secure (2) pinion box end covers (HH) to pinion box end sections with (6) round hd. screws (Y), position pinion box cover (Z) and secure with (6) hex. hd. self tapping screws (AA) as shown in Fig. 12.
- J. Grease both sides of swing arm washer and position it on swing arm anchor plate.
- K. Apply grease to pivot contact surfaces of swing arm and insert them into swing arm anchor plate.
- L. Secure swing arms with the appropriate hardware shown in the appropriate Fig. for your particular lift.
- M. Place lift adapter assy. on swing arms and secure each with (2) hex. hd. bolts. 1/2" x 1" lg. and (2) 1/2" lockwashers.

13. **IMPORTANT**

**OPERATING INSTRUCTIONS** The permanent operating instructions along with inspection and maintenance instruction furnished with this lift should be permanently and conspicuously displayed in the lift control area. Automotive lifts should be operated by trained personnel only. If you do not know how to position or lift a vehicle properly, do not guess. Get training. Start by reading the operating instructions, the booklet "Lifting It Right", and the "Automotive Lift Safety Tip" sheet furnished with the lift. Also refer to the vehicle manufacturer's service manual for proper lift points and lifting procedures.

14. **IMPORTANT**

**HOW TO ORDER REPLACEMENT PARTS**

Be sure to mention the lift model number and serial number in all correspondence dealing with service information and when ordering replacement parts. This information is on the top of the cylinder assembly.

15. **IMPORTANT**

Underground corrosion takes place in varying degrees throughout the United States and may cause a major problem with lift equipment. To protect underground lift components, MANITOWOC LIFTS recommends that an analysis of local soil conditions be obtained., and that a knowledgeable source be consulted relative to the implementation of an adequate corrosion control system.

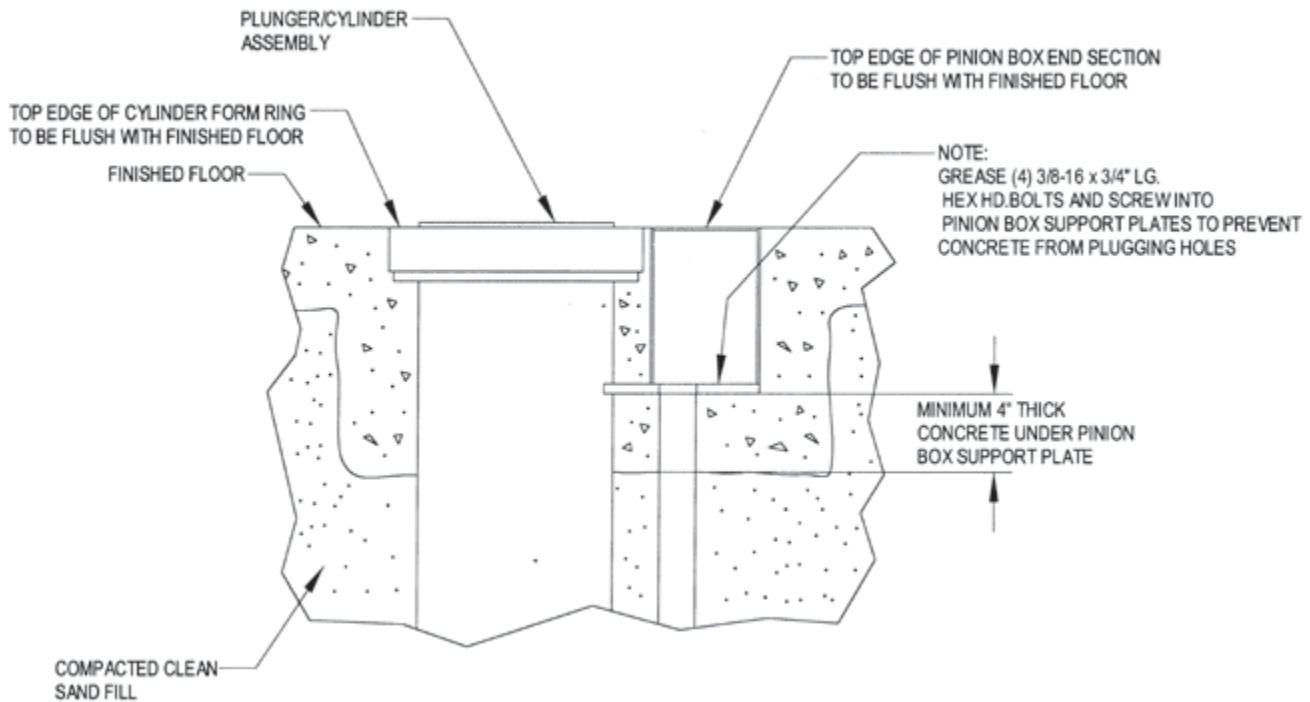

## INSTALLATION DETAIL TYPICAL BOTH PLUNGER/CYLINDER ASSEMBLIES

FIG. 6

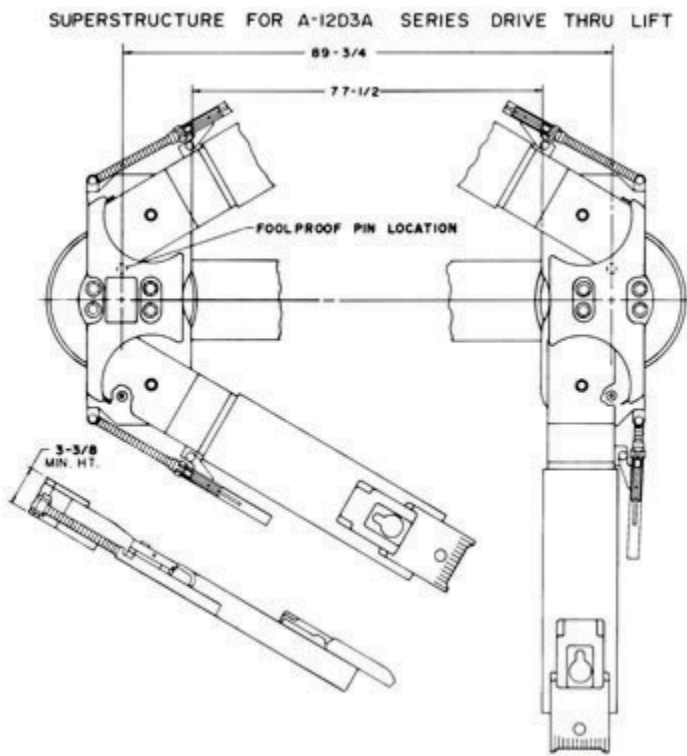

SEE PAGE 14 FOR PARTS BREAKDOWN

R16290

FIG. 7

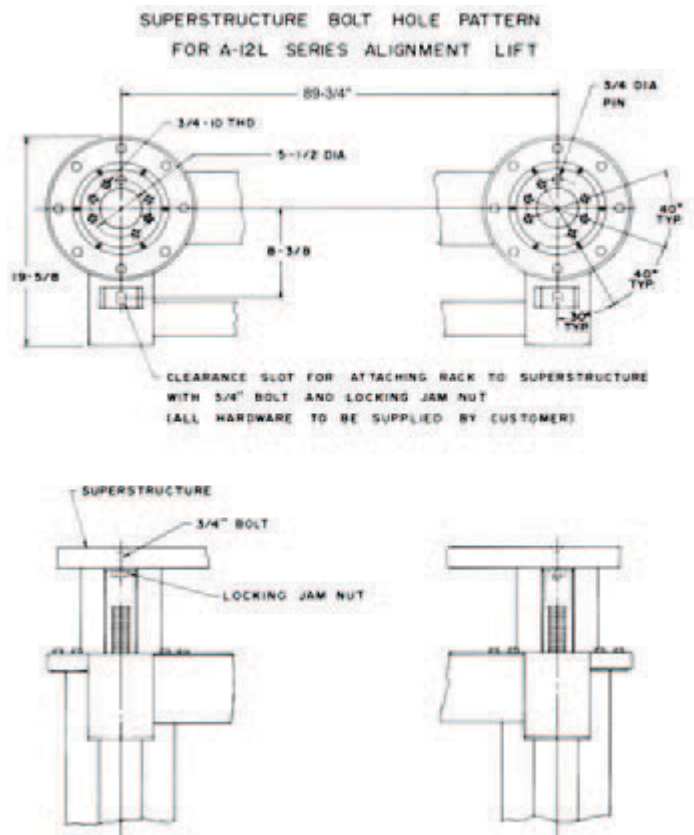

R18225

FIG. 9

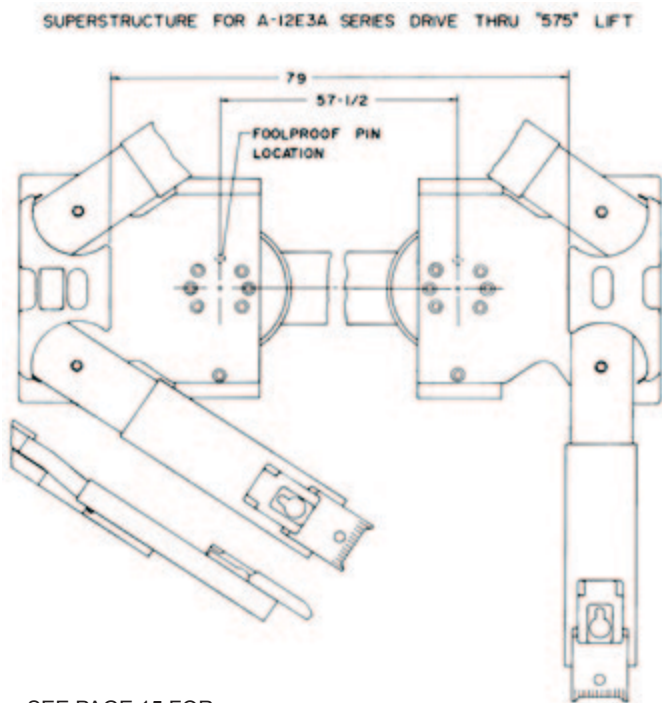

SEE PAGE 15 FOR PARTS BREAKDOWN

R16291

FIG. 8

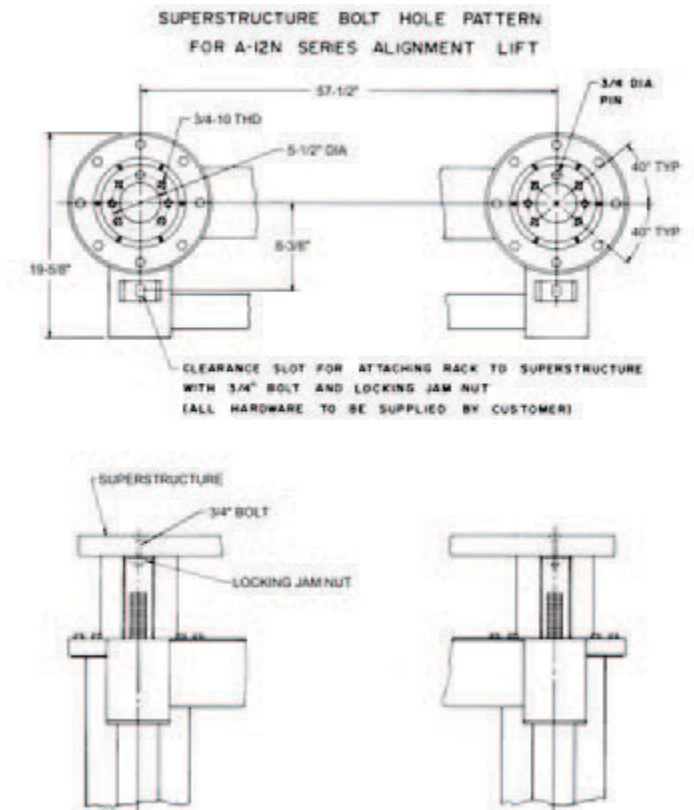

R16292

FIG. 10

# "AS INSTALLED" PIPING PLAN

**INSTALLER:** Sketch "As Installed" Piping Locations, In Case Future Excavation is Required.

## NOTES:

When ordering replacement parts, always mention lift model number and serial number.

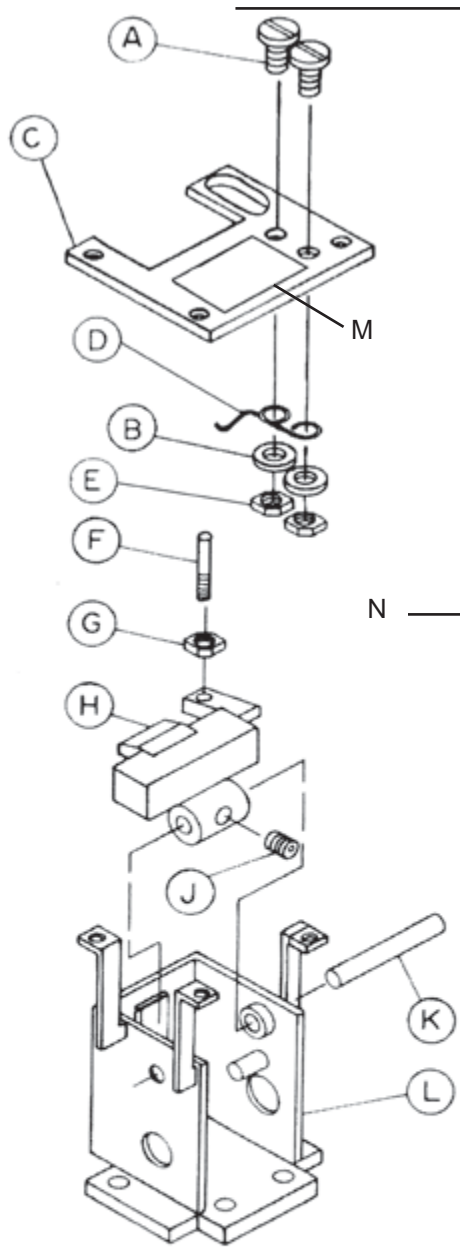

Code No.	No. Req.	Symbol No.	Description
A	2	K95104	Flat Hd. Screw 1/4-20 x 5/8"
B	2	K65235-20	Flat Washer 1/4"
C	1	R13105	Pinion Box Cover-Auto Latch
D	1	N19704	Spring
E	2	Q10218-06	Hex Nut Self Locking 1/4-20
F	1	K88435	Handle
G	1	K01934	Hex Jam Nut 3/8-16
H	1	R13382	Automatic Latch
J	1	K82287-20	Set Screw Locking 1/4-20 x 5/16"
K	1	K87045	Latch Shaft
L	1	R13422	Pinion Support
M	1	K95221	Warning Label
N	1	K88468	Auto Latch Kit

#### INSTALLATION

1. Raise the lift about two feet.
2. Attach the spring (D) to the underside of the left hand pinion box cover (C) using (2) 1/4-20 x 5/8 lg. flat head screws (A), (2) self locking nuts (E) and (2) flat washers (B).
3. Screw jam nut (G) on handle (F) and then screw handle (F) into auto latch (H) until approximately 1/4 to 3/8 inch of it protrudes through the bottom of the auto latch. Lock handle (F) in position with jam nut (G).
4. Insert the completed latch assembly into the left hand pinion support (L) and slide latch shaft (K) through the pinion support and latch assembly. Secure it with a 1/4-20 set screw (J).
5. Attach the pinion cover and spring assembly to the pinion box.

#### OPERATION AND ADJUSTMENT

**WARNING:** Latch does not automatically reset after lowering except at bottom of stroke.

1. Disengage the automatic latch by pulling the handle (F) back until spring (D) engages the latch. This holds the automatic latch open and the lift can be lowered.
2. The latch is reset automatically when the lift reaches the bottom of the stroke and the superstructure contacts the handle (F). If the latch does not reengage at the bottom of the stroke, it means that handle (F) does not protrude through the pinion box cover enough and must be adjusted out further until the superstructure contacts it.
3. Spring (D) should be installed to contact automatic latch (H). Latch must remain trapped behind the spring until the lift is fully lowered and the superstructure contacts the handle to reset the automatic latch. See assembled view.

#### NOTE:

**When adjusting the latch mechanism make sure that the handle (F) does not hit the pinion box cover when the latch is engaged. The handle must pass through the hole when the lift is settled on the latches. If the handle cannot pass through the pinion box cover hole the handle may break.**

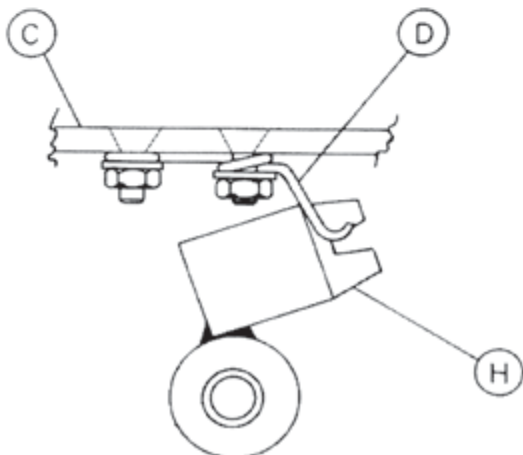

ASSEMBLED VIEW

## AUTOMATIC LATCH ASSEMBLY

Fig. 11

When ordering replacement parts, always mention lift model number and serial number

**NOTE:**

SEE FIG. 11 FOR AUTOMATIC LATCH INSTALLATION

**NOTE!**

USE TORQUE WRENCH TO TIGHTEN BOLTS "R" TO 21 FT/LBS OF TORQUE DRY OR LIGHTLY LUBRICATED FOR PROPER TIGHTNESS.

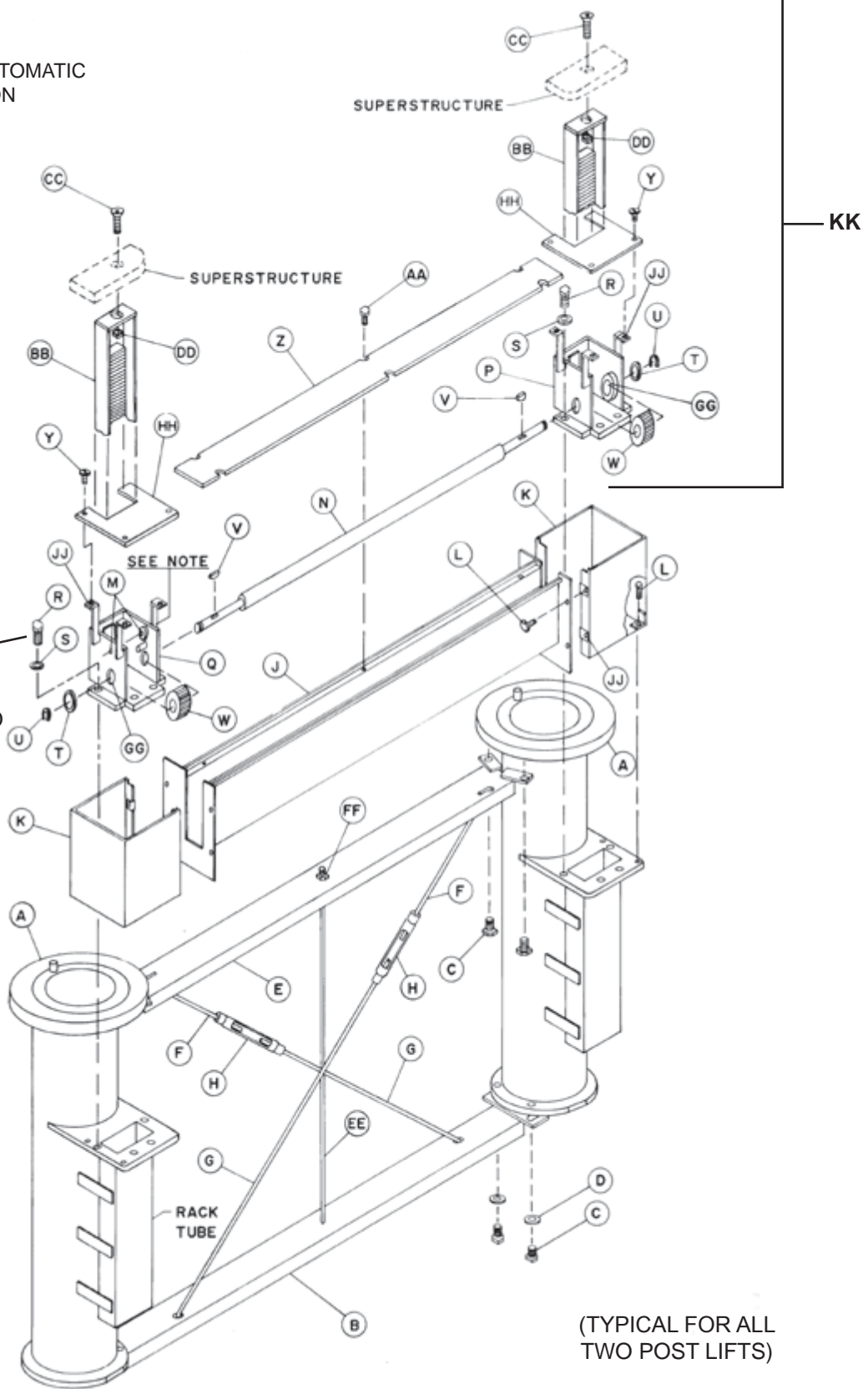

(TYPICAL FOR ALL TWO POST LIFTS)

FIG. 12

**ASSEMBLY OF: RACK AND PINION, PINION BOX, CYLINDER WITH UPPER AND LOWER BRACE**

When ordering replacement parts, always mention lift model number and serial number.

Code No.	No. Req'd.	Symbol No.	Description	
A	2	T13916-01	Plunger & Cylinder Assembly (See Page 16)	(Model 12D)(Model 12L) (Model 12E)(Model 12N)
B	1	R16266-01	Lower Brace	(Model 12D)(Model 12L)
B	1	R16266-02	Lower Brace	(Model 12E)(Model 12N)
C	8	K01909	Hex Hd. Bolt 1/2"-13 x 1"	
D	4	K02208	Flat Washer 1/2"	
E	1	R16267-01	Upper Brace	(Model 12D)(Model 12L)
E	1	R16267-02	Upper Brace	(Model 12E)(Model 12N)
F	2	N19267-02	Tie Rod-Upper	
G	2	N19267-04	Tie Rod-Lower	(Model 12D)(Model 12L)
G	2	N19267-05	Tie Rod-Lower	(Model 12E)(Model 12N)
H	2	Q10103-05	Turn Buckle	
J	1	N19271	Pinion Box Ctr. Sect.	(Model 12D)(Model 12L)
J	1	N19271-01	Pinion Box Ctr. Sect.	(Model 12E)(Model 12N)
K	2	N19264	Pinion Box End Sect.	
L	12	K05287	Hex Hd. Bolt 1/4"-20 x 1/2"	
M	2	N16990-55	Bearing (Part of Q)	
N	1	N19303-02	Pinion Shaft Assy.	(Model 12D)(Model 12L)
N	1	N19303-03	Pinion Shaft Assy.	(Model 12E)(Model 12N)
P	1	R13423	Pinion Support R.H.	
Q	1	R13422	Pinion Support L.H.	
R	8	Q10412-07	Hex Hd. Bolt 3/8"-16 x 1"	
S	8	K50775	Lockwasher 3/8"	
T	2	K65235-24	Flat Washer 1 5/16"	
U	2	K74051	Retaining Ring	
V	2	K07536-01	Woodruff Key	
W	2	K87046	Pinion	
Y	6	K95104	Flat Hd. Screw 1/4"-20 x 5/8"	
Z	1	R13065	Pinion Box Cover-Center	(Model 12D)(Model 12L)
Z	1	R13065-01	Pinion Box Cover-Center	(Model 12E)(Model 12N)
AA	6	K60521-24	Hex Hd. Self Tapping Screw #14 x 5/8"	
BB	2	N19253	Rack Assy.	
CC	2	Q10098-87	Flat Hd. Screw 3/4"-10 x 2"	(Model 12D)
CC	2	Q10035-29	Socket Hd. Cap Screw 3/4"-10 x 1 1/2"	(Model 12E)
DD	2	Q10404-01	Lock Nut 3/4"-10	
EE	1	K89121	Tie Rod	(Model 12D)(Model 12L)
FF	2	K01945	Hex Nut 1/2"-13	(Model 12D)(Model 12L)
GG	2	N16990-36	Bearing (Part of P & Q)	
HH	2	R13105	Pinion Box Cover - Auto Latch	
JJ	14	K81038-24	Speed Nut Type "U" 1/4"-20	
KK	1	K34133	Pinion Support Kit(Includes items from Page 11)	(Model 12D & 12L)
KK	1	K34134	Pinion Support Kit(Includes items from Page 11)	(Model 12E & 12N)

When ordering replacement parts, always mention lift model number and serial number.

Code No.	No. Req.	Symbol No.	Description
A	1	R18253-G1	Swing Arm Anchor Plate
B	1	R18253-G2	Swing Arm Anchor Plate W/Name Plate
C	8	Q10035-34	Soc. Hd. Cap Screw 3/4"-10 x 2-3/4"
D	8	K02216	Lockwasher 3/4"
E	4	K85825	Pivot Swing Arm
F	4	K02215	Lockwasher 7/16"
G	4	K78272	Hex Hd. bolt 7/16"-14 x 2-1/4"
H	4	N21841	Swing Arm
J	4	K87033	Swing Arm Washer
K	12	K01909	Hex Hd. Bolt 1/2"-13 x 1"
L	4	K02455	Lockwasher 1/2"
M	4	R12956-02	Sliding Base Assembly
N	4	R12709-02	Swivel Pad Base
P	4	R16123-02	Pickup Pad (With Protruded Ends)
Q	4	Q10038-04	Spirol Pin

Code No.	No. Req.	Symbol No.	Description
R	4	N20366-02	Lift Adapter Assembly (includes M,N,P&Q) (With Protruded Ends)
S	1	K62563	Positioning Rod
T	8	A-493-14	Cotter Pin 1/8"Dia. x 1" Lg.
U	4	A-491-191	Clevis Pin 1/2" Dia. x 1-1/2" Lg.
V	4	Q10167-14	Clevis Pin 3/8" Dia. x 1" Lg.
W	2	R19026	Arm Restraint Asm LH
X	2	R19027	Arm Restraint Asm RH
Y	4	N21840	Swing Attachment Bar
AA	1	T07915	Wheel Stop
BB	2	K03782	Hex Hd. Bolt 5/16"-18 x 1-3/4" Lg.
CC	2	K79695	Expansion Shield

\* 150,000 PSI Min. Tensile Strength Bolts.

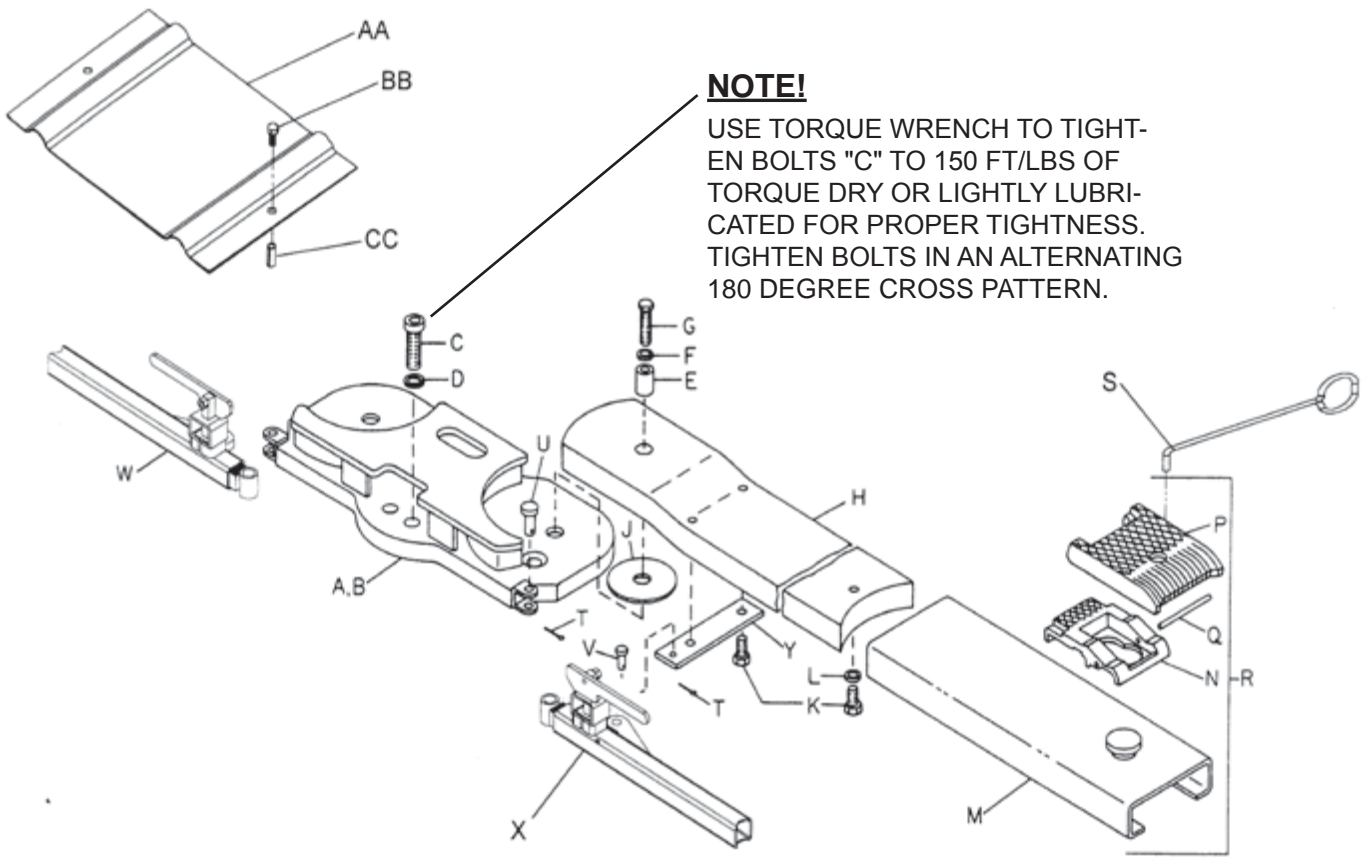

**MODEL A-12D3A**

**SWING-RAIL TWO POST DRIVE-THRU SUPERSTRUCTURE**

When ordering replacement part, always mention lift model number and serial number.

Code No.	No. Req'd.	Symbol No.	Description
A	1	T13914-01	Swing Arm Anchor Plate
B	1	T13914-02	Swing Arm Anchor Plate W/Name Plate
* C	12	Q10035-34	Soc. Hd. Cap Screw 3/4"-10 x 2 3/4"
E	4	K85825	Pivot Swing Arm
F	4	K02215	Lockwasher 7/16"
G	4	K78272	Hex Hd. Bolt 7/16"-14 x 2 1/4"
H	4	N20275	Swing Arm
J	8	K87033	Swing Arm Washer
K	8	K01909	Hex Hd. Bolt 1/2"-13 x 1"
L	8	K02455	Lockwasher 1/2"
M	4	R12956-02	Sliding Base Assembly
N	4	R12709-02	Swivel Pad Base
P	4	R16123-02	Pickup Pad (With Protruded Ends)
Q	4	Q10038-04	Spiral Pin
R	4	N20366-02	Lift Adapter Assembly (Includes M, N, P, & Q) (With Protruded Ends)
S	1	K62563	Positioning Rod
T	1	T07915	Wheel Stop
U	2	K03782	Hex Hd. Bolt, 5/16"-18 x 1-3/4" Lg.
V	2	K79695	Expansion Shield

\* 150,000 PSI MIN. TENSILE STRENGTH BOLT

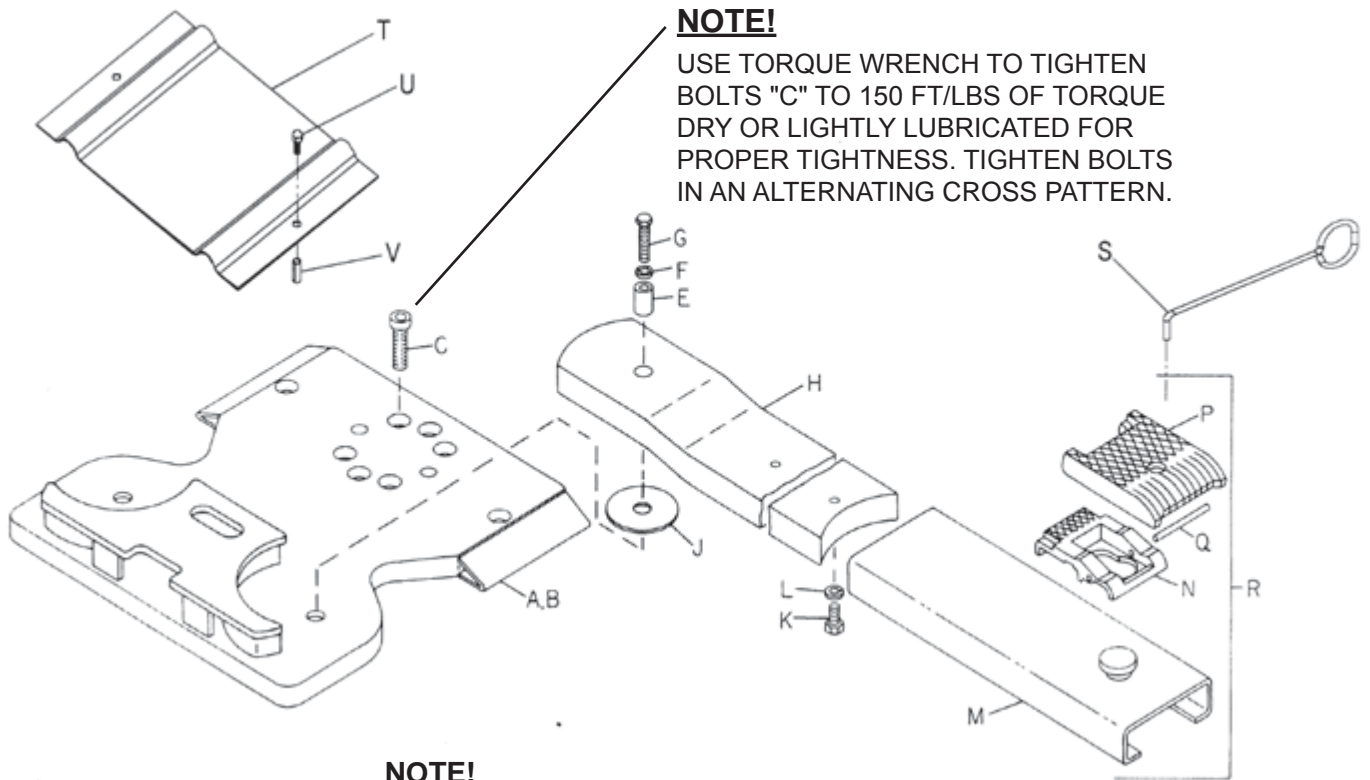

## MODEL A-12E3A SWING-RAIL TWO POST DRIVE-THRU "575" SUPERSTRUCTURE

When ordering replacement parts, always mention lift model number and serial number.

Code No.	No. Req'd.	Symbol No.	Description
A	2	T13916-01	Plunger & Cylinder Assy.
B	2	T13912-G1	Plunger Assembly
C	2	T13911-02	Upper Bearing
D	2		Felt Wiper
E	16	Q10034-82	Soc. Hd. Bolt 1/2"-13 x 2"
F	2	T13915-01	Wiper Retainer
G	12	Q10034-28	Soc. Hd. Bolt 3/8"-16 x 3/4"
H	2	N21812-G1	Air Vent
J	2		Wiper
K	2		Seal
L	2		O-Ring
M	2	K34300	Seal Kit (Includes J, K, & L)

**NOTE!**

WHEN REASSEMBLING PARTS "F" & "C" USE TORQUE WRENCH TO TIGHTEN BOLTS "E" TO 75 FT/LBS OF TORQUE DRY OR LIGHTLY LUBRICATED AND BOLTS "G" TO 21 FT/LBS OF TORQUE DRY OR LIGHTLY LUBRICATED FOR PROPER TIGHTNESS. TIGHTEN BOLTS IN AN ALTERNATING CROSS PATTERN.

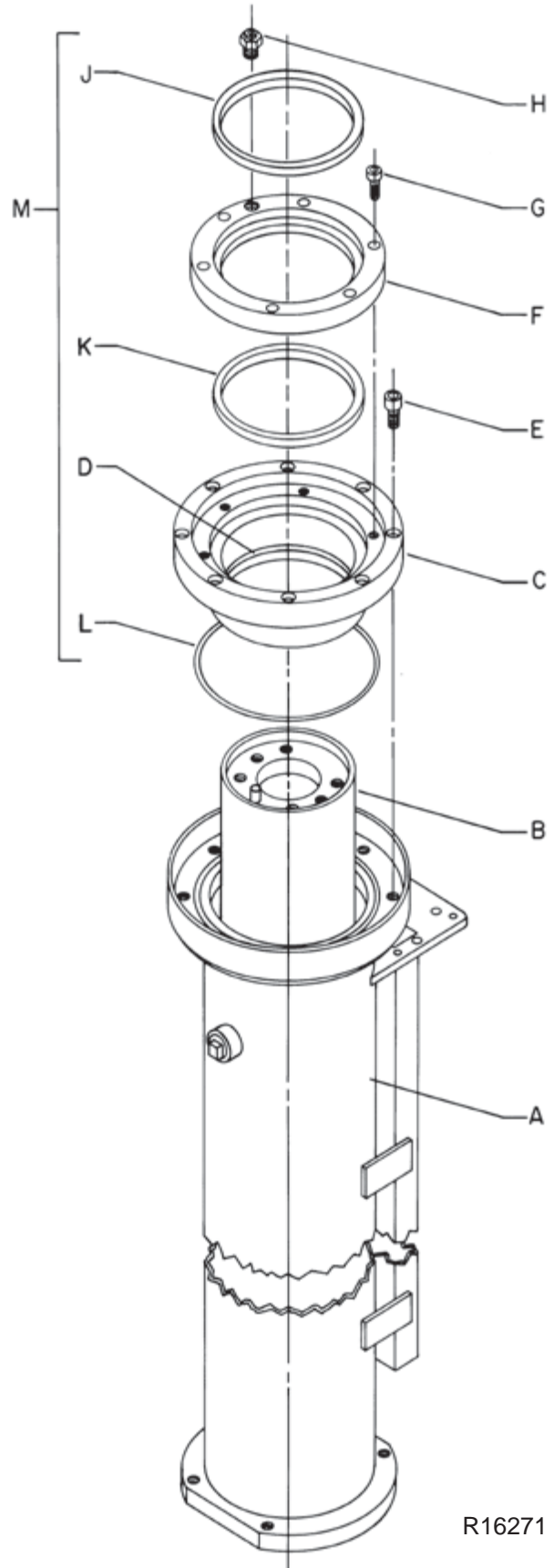

**NOTE:**

WHEN ORDERING PLUNGER ASSY., SPECIFY SYMBOL NO. AND BEARING CODE LETTER STAMPED ON TOP OF PLUNGER. FOR REPLACEMENT PLUNGER ORDER KIT NO. K92930.

R16271

**PLUNGER AND CYLINDER ASSEMBLY**  
(TYPICAL FOR ALL TWO POST LIFTS)

When ordering replacement parts, always mention lift model and serial number.

Code No.	No. Req.	Symbol No.	Description
A	1	K81439	Muffler
B	1	N19687-01	Oil Gauge Assy. (1-1/2" Plug)
D	1	R18219-G1	Oil Tank with Oil Gauge Installed
E	1	K68832-01	Two-way Air Valve (See Page 18, Fig.13 & Fig.14)
H	1	N23105	Oil Valve (See Page 18, Fig. 15)
J	1	K86957	Float Assy.

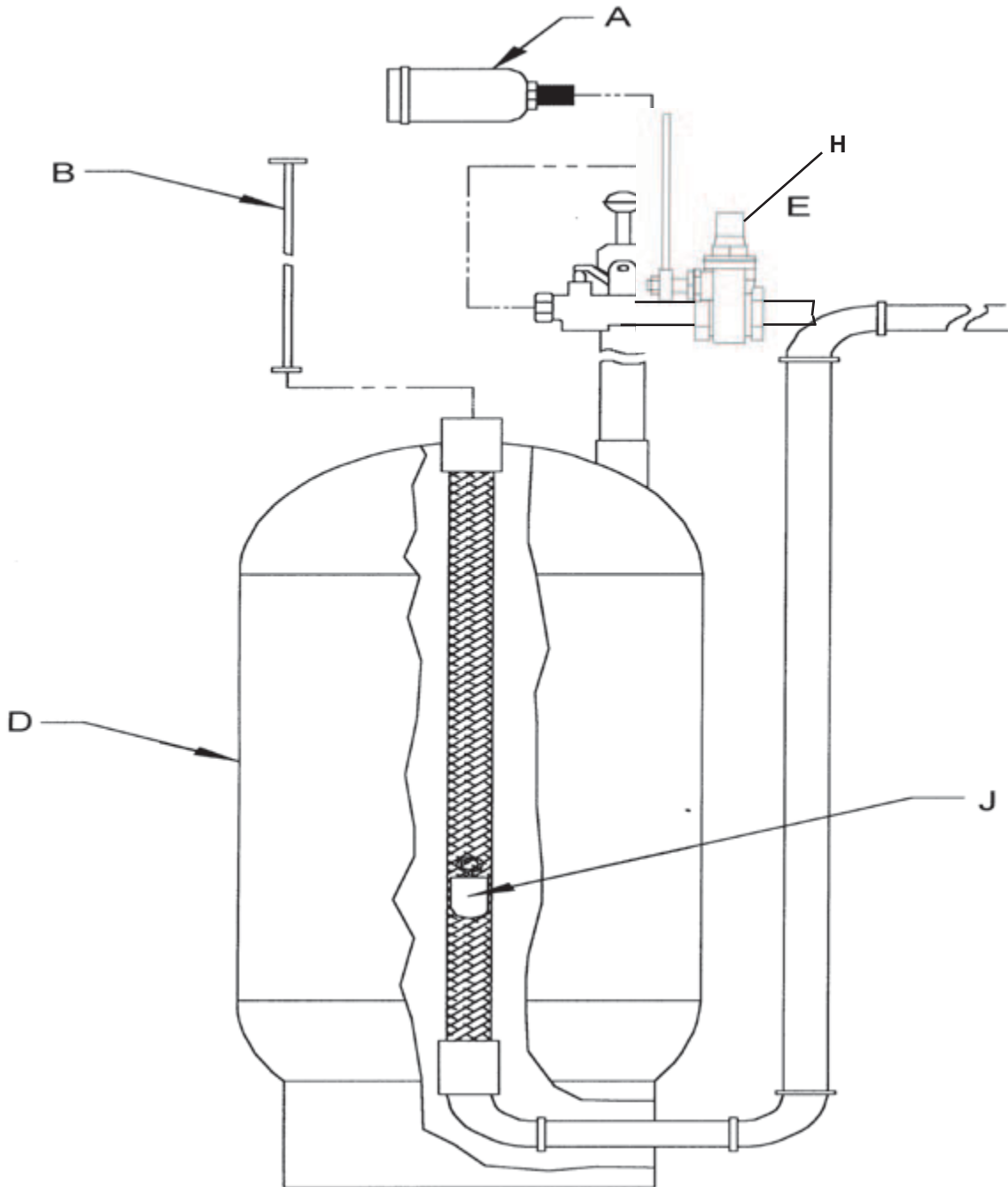

## OIL TANK, GAUGE, VALVES, ETC.

When ordering replacement parts, always mention lift model number and serial number.

### REPAIR PARTS

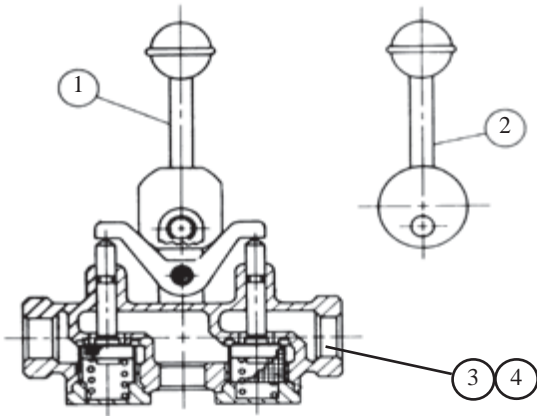

FIG. 13  
**AIR VALVE**

ITEM	PART #	DESCRIPTION
1	K34361	LOCKING HANDLE KIT (CONSISTS OF A CLEVIS PIN, RETAINING RINGS & HANDLE)
2	K34362	DEADMAN HANDLE KIT (CONSISTS OF A CLEVIS PIN, RETAINING RINGS & HANDLE)
3	K68832	LOCKING TYPE AIR VALVE w/ HANDLE (FULL HYDRAULIC WALL CONTROL)
4	K85963	DEADMAN TYPE AIR VALVE w/ HANDLE (SEMI-HYDRAULIC WALL CONTROL)

FOR AIR VALVE REPLACEMENT PARTS, DETERMINE MFG. OF VALVE:  
IF MFG. IS KINGSTON, USE PARTS LIST BELOW (FIG. 14)  
IF MFG. IS CONSOLIDATED BRASS AND VALVE HAS A TWO-PIECE HANDLE WITH A PLASTIC KNOB, USE PARTS LIST ABOVE (FIG. 13)

### REPAIR PARTS

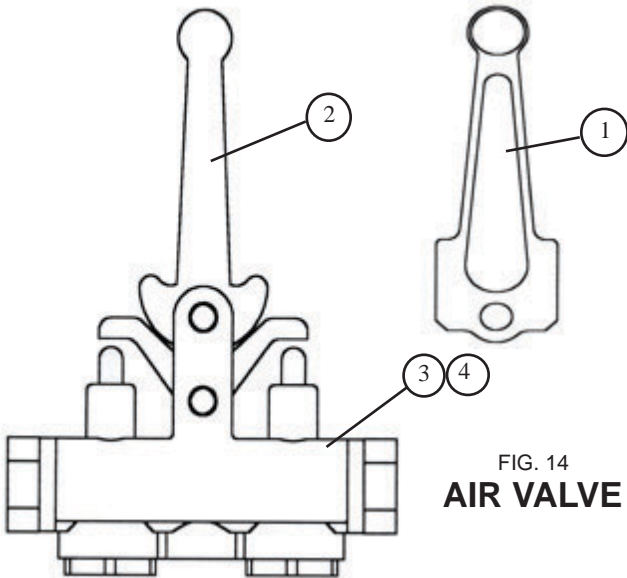

FIG. 14  
**AIR VALVE**

ITEM	PART #	DESCRIPTION
1	K34363	LOCKING HANDLE KIT (CONSISTS OF A CLEVIS PIN, RETAINING RINGS & HANDLE)
2	K34364	DEADMAN HANDLE KIT (CONSISTS OF A CLEVIS PIN, RETAINING RINGS & HANDLE)
3	K68832-01	LOCKING TYPE AIR VALVE w/ HANDLE (FULL HYDRAULIC WALL CONTROL)
4	K85963-02	DEADMAN TYPE AIR VALVE w/ HANDLE (SEMI-HYDRAULIC WALL CONTROL)

### WALL CONTROL VALVE

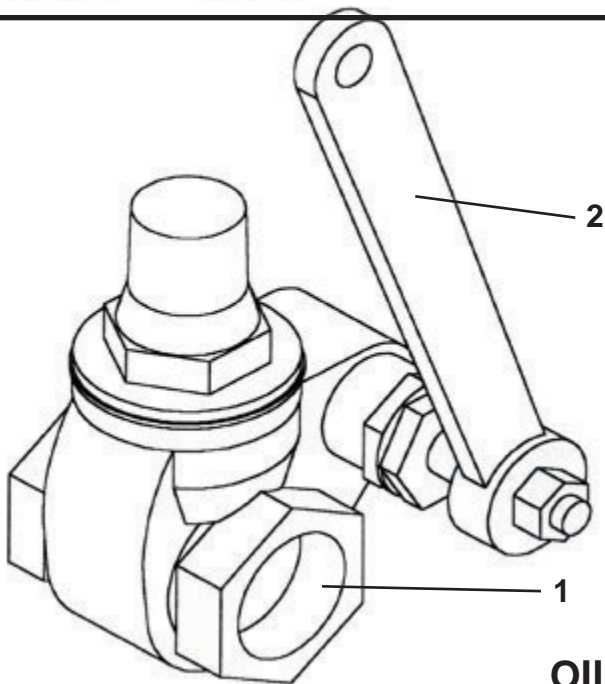

FIG. 15  
**OIL VALVE**

ITEM	DESCRIPTION	PART #
1	OIL VALVE W/HANDLE	N23105
2	REPLACEMENT HANDLE	N23105-01

**PULL HANDLE TO ACTIVATE  
SPRING RETURN**



**FRONT**

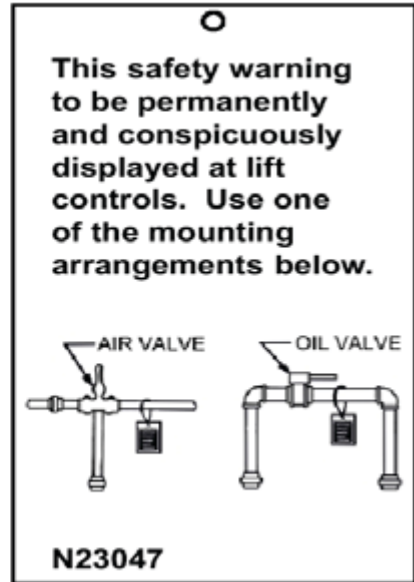

**BACK**



**FRONT**

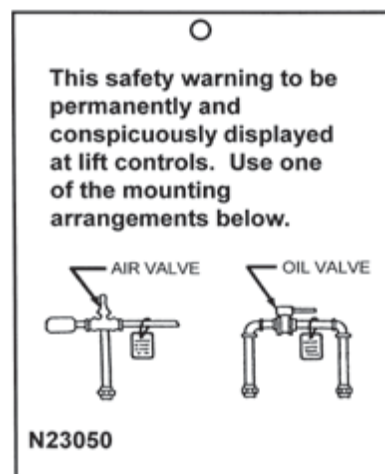









**BACK**

**SAFETY WARNING PLACARDS**

# SAFETY WARNING LABELS FOR INGROUND LIFTS











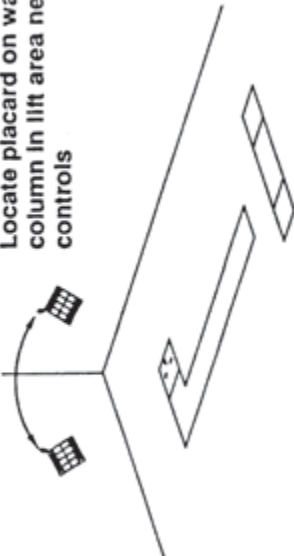

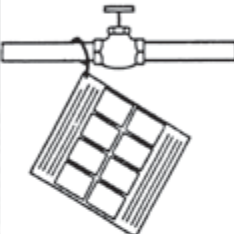
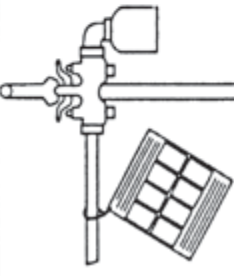
Lift Owner/User Responsibilities:

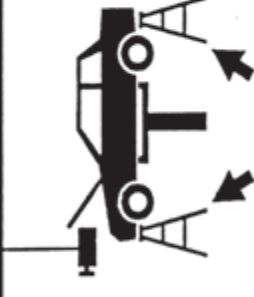
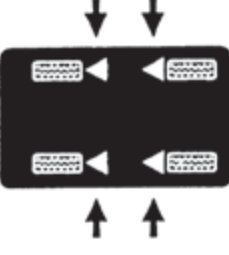
- A. This Safety Warning placard **SHALL** be displayed in a conspicuous location in the lift area back of this placard
- C. These Safety Warning labels supplement other documents supplied with the lift.
- D. Be certain all lift operators read and understand these labels, operating instructions and other safety related information supplied with the lift.

	<b>▲ WARNING</b> Do not override self-closing lift controls.		<b>▲ WARNING</b> DO NOT remove oil fill plug before reading manufacturer's manuals.		<b>▲ WARNING</b> Position vehicle center of gravity over lift.		<b>▲ WARNING</b> Remain clear of lift when raising or lowering vehicle.		<b>▲ WARNING</b> Keep feet clear of lift while lowering.
	<b>▲ WARNING</b> Clear area if vehicle is in danger of falling.		<b>▲ WARNING</b> Avoid excessive rocking of vehicle while on lift.		<b>▲ WARNING</b> Chock wheel to prevent vehicle movement.		<b>▲ WARNING</b> Use lift locking device or 4 stands to support vehicle.	<p>The messages and pictographs shown are generic in nature and are meant to generally represent hazards common to all automotive lifts regardless of specific style.</p> <p>Funding for the development and validation of these labels was provided by the Automotive Lift Institute, PO Box 1519 New York, NY, 10101-1519.</p> <p>They are protected by copyright. Set of labels may be obtained from ALI or its member companies.</p> <p>© 1992 by ALL, Inc. ALI-WL500W</p>	

## SAFETY WARNING LABELS

# TYPICAL PLACARD LOCATIONS

<p><b>In-floor Lift Controls:</b> Locate placard on wall or column in lift area near lift controls</p> 	 <p><b>Push Button Controls on Electric Powered Lifts</b></p>	 <p><b>Air Supply To Lift</b></p>	 <p><b>Wall Mounted Lift Control</b></p>	<p><b>CAUTION</b></p>  <p><b>Use height extenders when necessary to ensure good contact.</b></p>	<p><b>CAUTION</b></p>  <p><b>Always use safety stands when removing or installing heavy components.</b></p>	<p><b>CAUTION</b></p>  <p><b>Use vehicle manufacturer's lift points.</b></p>	<p><b>CAUTION</b></p>  <p><b>Authorized personnel only in lift area.</b></p>	<p><b>CAUTION</b></p>  <p><b>Lift to be used by trained operator only.</b></p>	<p><b>SAFETY INSTRUCTIONS</b></p>  <p><b>Do not operate a damaged lift.</b></p>	<p><b>SAFETY INSTRUCTIONS</b></p>  <p><b>Proper maintenance and inspection is necessary for safe operation.</b></p>	<p><b>SAFETY INSTRUCTIONS</b></p>  <p><b>Read operating and safety manuals before using lift.</b></p>	<p><b>CAUTION</b></p>  <p><b>Auxiliary adapters may reduce load capacity.</b></p>	<p><b>SAFETY INSTRUCTIONS</b></p>  <p><b>Proper maintenance and inspection is necessary for safe operation.</b></p>
----------------------------------------------------------------------------------------------------------------------------------------------------------------------------------------------	-------------------------------------------------------------------------------------------------------------------------------------------------	----------------------------------------------------------------------------------------------------------------------	-----------------------------------------------------------------------------------------------------------------------------	-----------------------------------------------------------------------------------------------------------------------------------------------------------------------------------	----------------------------------------------------------------------------------------------------------------------------------------------------------------------------------------------	----------------------------------------------------------------------------------------------------------------------------------------------------------------	-----------------------------------------------------------------------------------------------------------------------------------------------------------------	-------------------------------------------------------------------------------------------------------------------------------------------------------------------	--------------------------------------------------------------------------------------------------------------------------------------------------------------------	---------------------------------------------------------------------------------------------------------------------------------------------------------------------------------------------------------	--------------------------------------------------------------------------------------------------------------------------------------------------------------------------------------------	------------------------------------------------------------------------------------------------------------------------------------------------------------------------	----------------------------------------------------------------------------------------------------------------------------------------------------------------------------------------------------------

The messages and pictographs shown are generic in nature and are meant to generally represent hazards common to all automotive lifts regardless of specific style.

Funding for the development and validation of these labels was provided by the Automotive Lift Institute, PO Box 1519 New York, NY, 10101-1519.

They are protected by copyright. Set of labels may be obtained from ALI or its member companies.

© 1992 by ALI, Inc. ALLIWL50004e

## SAFETY WARNING LABELS



# MANITOWOC LIFTS

[www.manitowoclifts.com](http://www.manitowoclifts.com)

---

[www.sviinternational.com](http://www.sviinternational.com)

**(800) 321-8173 • fax: (800) 899-1784**

Main Office: 155 Harvestore Drive • DeKalb, IL