

# Gasboy Consumer Products

R E P A I R P A R T S



**(800) 321-8173 • fax: (800) 899-1784**

155 Harvestore Drive • DeKalb, IL 60115

**[www.sviinternational.com](http://www.sviinternational.com)**

BALTIMORE • CHICAGO • LOS ANGELES

Repair Parts for:  
Gasboy  
Consumer  
Products  
PRC4210

Repair Parts for: Gasboy Consumer Products



# 70 Series - Assembly

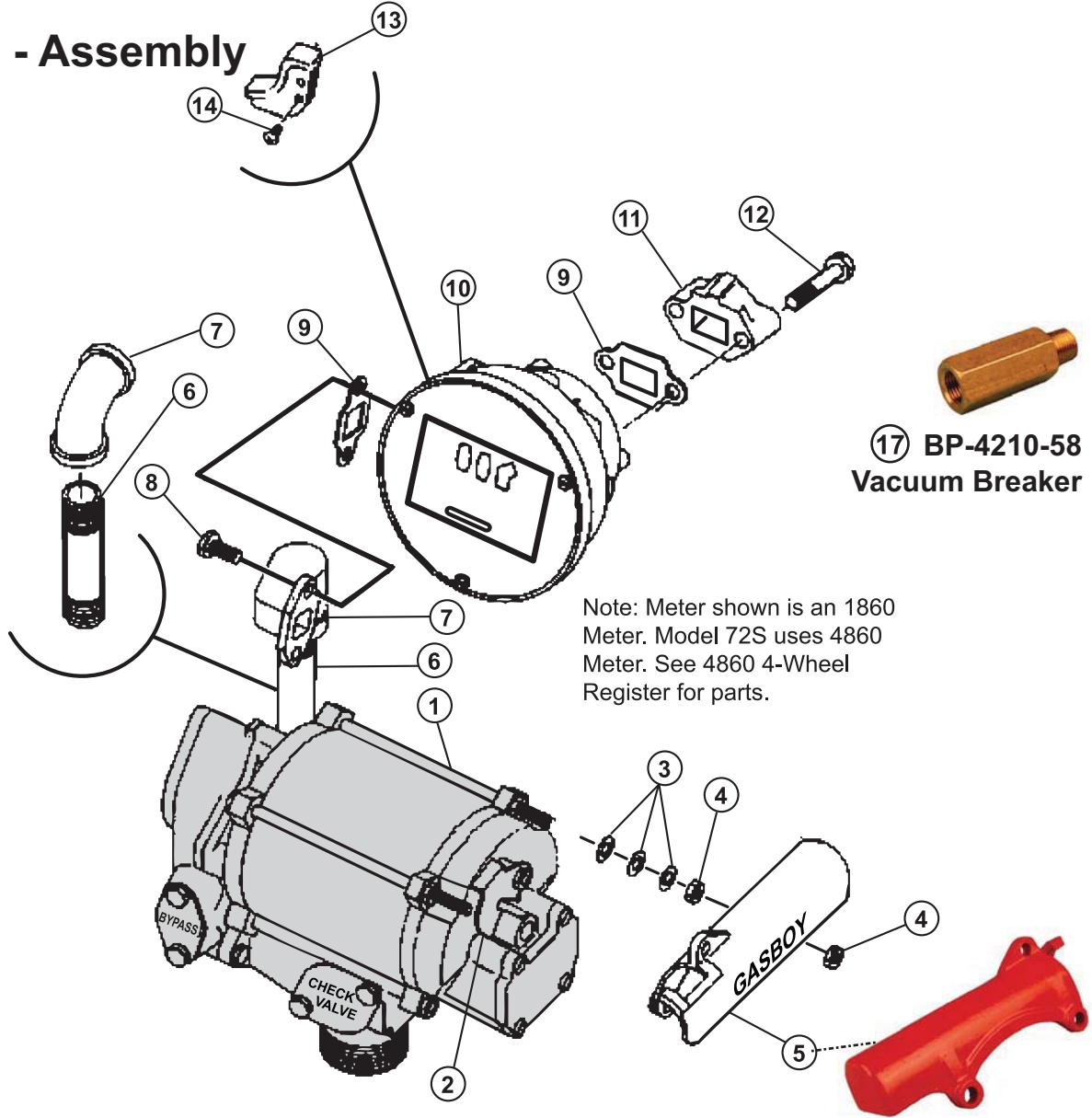

Item	SVI part #	OEM #	Description
1	BP-4218-20R	F37332	1/3 HP Motor 60 Hz. 48 Frame (Red) (use suffix 20B for beige and 20W for white)
	BP-4218-21	F37325	1/3 HP Motor 50/60 Hz. 48 Frame
	BP-4218-22	F37461	1/3 HP Motor 50 Hz. 48 Frame
2	BP-4212-74	034121	Motor Switch Lever (old style units)
3	call for details	068020	Washer
		K65235 33	Washer
4	F-KN-0312-18	039085	Hex Nut
		Q12068 06	Hex Nut with Lockwasher
5	BP-4218-30R/B/W	000325	Nozzle Boot (R=Red, B=Beige, W=White)
6	BP-4210-106	044089	3/4" x 6-7/8" Pipe Nipple
		R11496 106	3/4" x 6-7/8" Pipe Nipple
7	BP-4212-112	003597	Flanged Inlet, 72S
	BP-4210-105	024934	Elbow, 72X & 73
8	call for details	052000	Screw
		K47659	Screw

Item	SVI part #	OEM #	Description
9	BP-4210-20	027055	Gasket
		M05618B001	Gasket
10	call for details		Meter Register Assembly **See Section on 1860 3-Wheel Meter Register for internal parts
11	BP-4212-110	003542	3/4" Horiz. Dschg for Vacuum Breaker
12	BP-4218-04	052105	Screw
13	BP-4212-29	029410	Reset Lever Handle (only used with Vapor Recovery)
14	call for details	053900	Reset Lever Screw (only used on Model 72)
15	call for details	030539	Hose, 5/8 x 12 ft. (not shown)
	BP-4210-107	030605	Hose, 3/4" x 12 ft. (not shown)
16	BP-4210-109	038471	Nozzle, 3/4" EBW-unl. (not shown)
17	BP-4210-58	066534	Vacuum Breaker (not shown)

*continues on following page*

P  
a  
g  
e

## 70 Series - Assembly

### Optional Accessories

call for details	032814	Filter Kit (1820/1820R) contains * below
call for details	*017270	Bushing, 3/4" x 1"
	*K02297	Bushing, 3/4" x 1"
call for details	*043960	Pipe Tube, 3/4" x 2"
	*R11496 23	Pipe Tube, 3/4" x 2"
call for details	*003043	Adapter, Filter 3/4"
call for details	*024940	Elbow, Street 3/4" x 90
call for details	*026005	Filter, Wix 24006 Dsl/Gas
call for details	030340	Hose - 3/4" x 14 ft.
	030565	Hose - 3/4" x 15 ft.

call for details	030355	Hose - 3/4" x 15 ft.
	030566	Hose - 1" x 15 ft.
call for details	037461	Motor for 50 cycle, 230V
BP-4210-109	038471	Nozzle - 3/4" Manual - Unleaded
BP-4210-108	038475	Nozzle - 3/4" Manual - Leaded
call for details	038519	Nozzle - Automatic - Unleaded - Husky
call for details	038520	Nozzle - Automatic - Leaded - Husky
call for details	038510	Hook Assembly, OPW 11A
call for details	038511	Hook Assembly, EMCO A2000
call for details	038503	Hook Assembly, OPW 7H
BP-4210-59	032700	Kit, Vacuum Breaker Tubing and Fittings

## Series 1820 Assembly

### \*Slimline 390 Pump

See 1800 Series Pumps for part numbers.

Slimline 390 has same internal parts, with different housing.

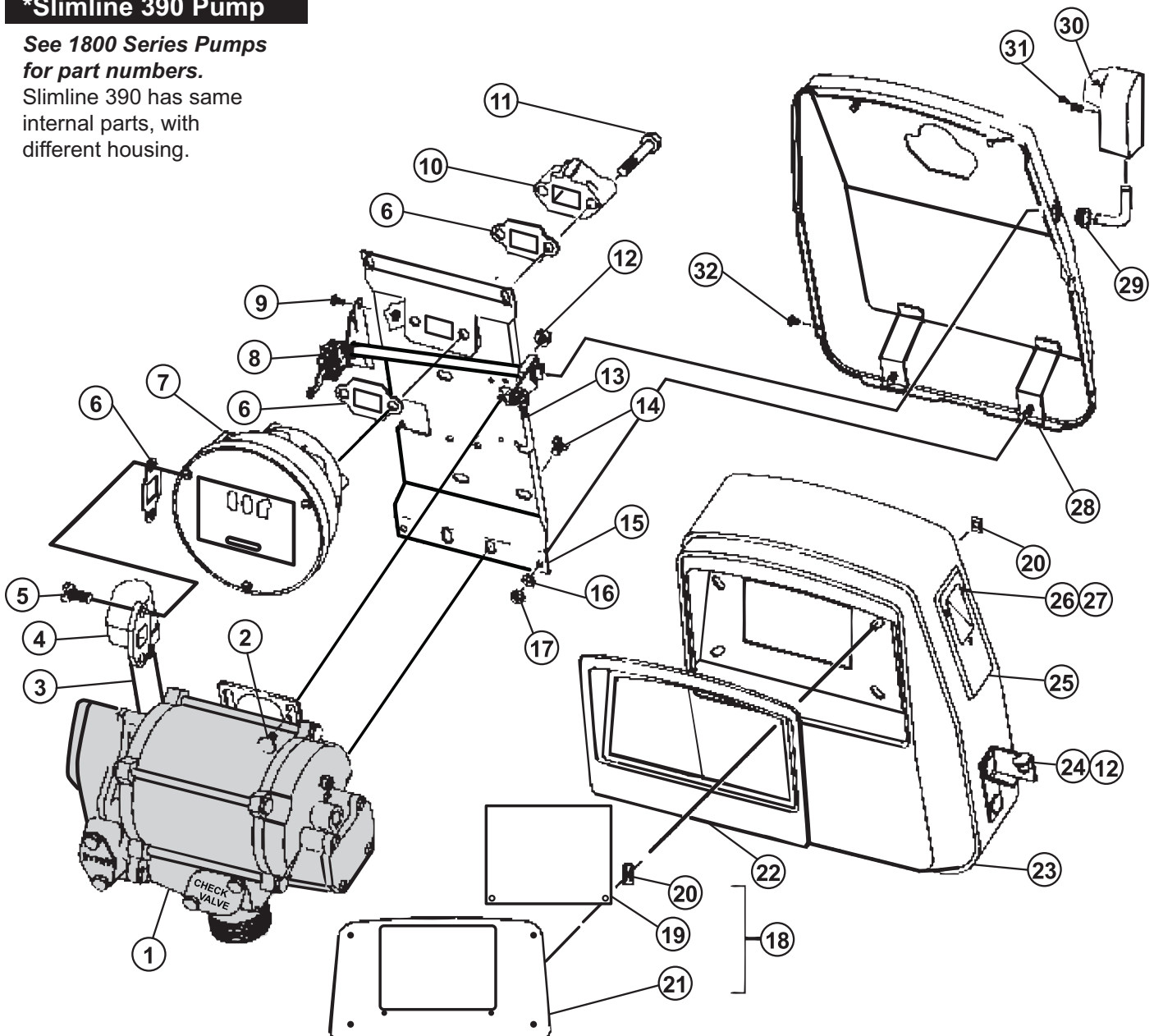



### Series 1820 Assembly (continued)

Item	SVI part #	OEM #	Description
1	BP-4218-28	F37697	1/3 HP Motor 60 Hz. 48 Frame
2	call for details	013030	Carriage Bolt
3	BP-4210-106	044089	3/4" x 6-7/8 Nipple
		R11496 106	3/4" x 6-7/8 Nipple
4	BP-4212-112	003597	Flanged Inlet (72S & 1820)
	call for details	003601	Flanged Inlet (1820R)
5	call for details	052000	Cap Screw
		K47659	Cap Screw
6	BP-4210-20	027055	Gasket
		M05618B001	Gasket
7	call for details		Meter-Register Assembly
	<i>**See Section on 1860 3-Wheel Meter Register for internal parts</i>		
8	call for details	054654	Control Shaft Assembly
9	call for details	052855	Machine Screw
		Q11560 53	Machine Screw
10	BP-4212-110	003542	Horiz. Dischg-3/4", for Vacuum Breaker
	call for details	003544	Horiz. Dischg-1" for Vacuum Breaker
		003645	Horiz. Dischg (1820R)
11	BP-4218-04	052105	Machine Screw, Horiz. Dischg
	BP-4212-111	K04395	Machine Screw, 3/8-16 x 2
	call for details	052555	Machine Screw, Flgd Dischg
12	call for details	038605	Keps Lock Nut
		Q12068 03	Keps Lock Nut
13	call for details	051206	Switch Rod Assembly
14	BP-4214-26	051880	Cap Screw 5/16-16 x 1/2 HHCS
		Q10624 13	Cap Screw

Item	SVI part #	OEM #	Description
15	call for details	063970	Pump and Meter Support
16	call for details	068891	1/4 Lock Washer
17	F-HN-0250-20	038860	1/4-20 Hex Nut
18	BP-4210-83	032912	Dial Face <b>Kit</b> (consists of 19, 20 & 21)
19	BP-4210-84	028850	Dial Glass (plastic) 1820 new style
20	BP-4210-85	039461	Speed Nut
21	BP-4210-81	025393	Dial Face Assembly
22	call for details	012265	Bezel
23	call for details	040630	Front Panel Assembly
24	call for details	029620	Nozzle Hanger
	BP-4210-68	029590	Nozzle Hanger - Automatic Nozzle
25	call for details	003820	Scuff Plate
26	call for details	052856	Machine Screw
27	BP-4211-33	039070	Keps Lock Nut
		Q12068 03	Keps Lock Nut
28	call for details	041545	Rear Panel Assembly
29	call for details	039815	Nyliner Bearing
30	call for details	003717	Control Lever
31	call for details	053170	Set Screw
32	call for details	053725	Self-Tapping Screw
33	call for details	030539	Hose-5/8" x 12 ft. (not shown)
	BP-4210-107	030605	Hose 3/4" x 12 ft. (not shown)
34	BP-4210-109	038471	Nozzle-Manual Unl. (not shown)
--	BP-4210-58	066534	Vacuum Breaker (see image below)

### Optional Accessories

call for details	032814	Filter Kit (1820/1820R) Contains * items below
call for details	*017270	Bushing, 3/4" x 1"
call for details	*043960	Pipe Tube, 3/4" x 2"
	*R11496 23	Pipe Tube, 3/4" x 2"
call for details	*003043	Adapter, Filter 3/4"
call for details	*024940	Elbow, Street 3/4" x 90
	*K21703	Elbow, Street 3/4" x 90
call for details	*026005	Filter, Wix 24006 Dsl/Gas
call for details	030340	Hose, 3/4" x 14 ft.
	030565	Hose, 3/4" x 15 ft.
call for details	030355	Hose, 3/4" x 15 ft.
	030366	Hose, 1" x 15 ft.
call for details	037461	Motor for 50 cycle, 230V
BP-4210-109	038471	Nozzle - 3/4" Manual - Unleaded
BP-4210-108	038475	Nozzle - 3/4" Manual - Leaded
call for details	038519	Nozzle - Automatic - Unleaded - Husky
call for details	038520	Nozzle - Automatic - Leaded - Husky
call for details	038510	Hook Assy., OPW 11A
call for details	038511	Hook Assy., EMCO A2000
call for details	038503	Hook Assy., OPW 7H

### Vacuum Breaker Tubing

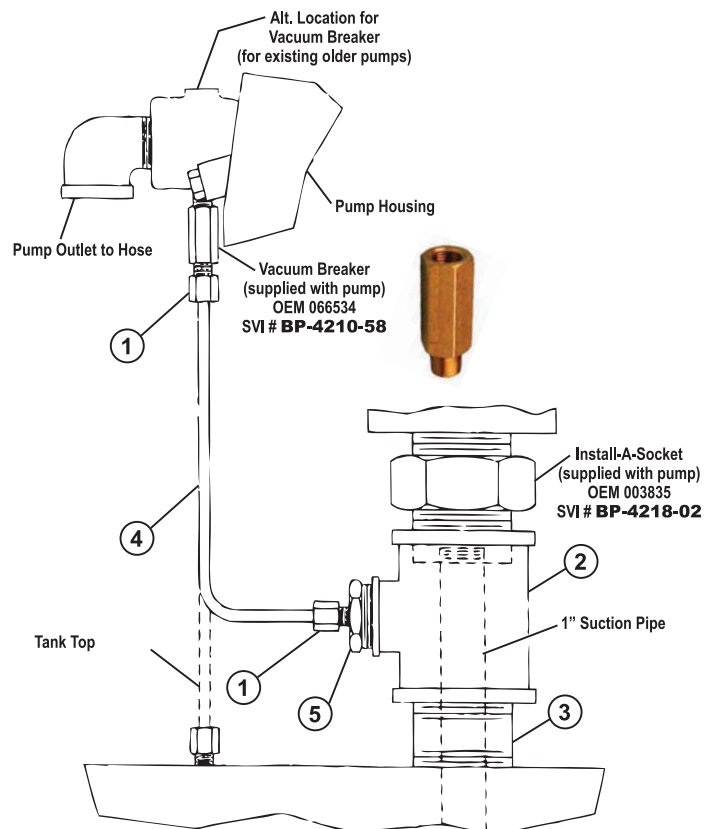

P  
a  
g  
e  
16

### Vacuum Breaker Tubing Kit

Item	SVI part #	OEM #	Description
<b>KIT</b>	<b>BP-4210-59</b>	<b>032700</b>	<b>Vacuum Breaker Tubing Kit</b>
1	BP-4210-59E	065620	1/4T x 1/8 NPT Fitting
2	BP-4210-59A	064805	2 x 2 x 3/4 Tee
3	BP-4210-59B	044946	2" Nipple x 3" Lg.
4	BP-4210-59D	066086	1/4 Copper Tubing
5	BP-4210-59C	017286	1/8 x 3/4 Bushing

## Series 70 & 1820 Direct Drive Motor-Pump Assembly

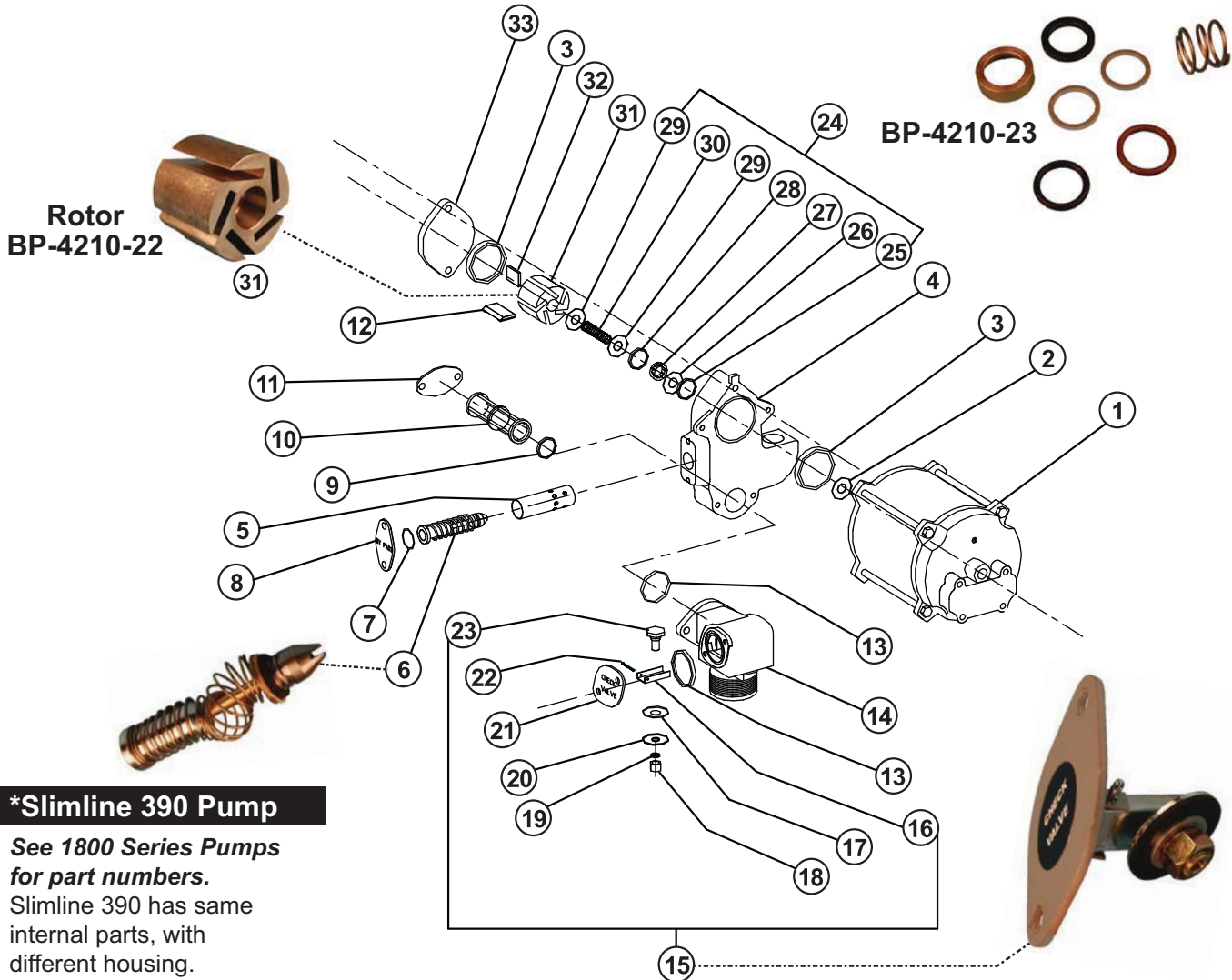

**\*Slimline 390 Pump**

See 1800 Series Pumps for part numbers. Slimline 390 has same internal parts, with different housing.

Item	SVI part #	OEM #	Description
1	BP-4218-20R	F37332	Motor, 115V, 60 Cycle, 70 Series (Red) (use suffix 20B for beige and 20W for white)
	BP-4218-28	F37697	Motor, 115V, 60 cycle, 1800 Series
	BP-4218-21	F37325	1/3 HP Motor 50/60 Hz., 48 Frame, 70 Series
	BP-4218-24	F37616	Motor, 230V, 50 cycle, 70 Series
	BP-4218-22	F37461	Motor, 230V, 50 cycle, 1800 Series
2	BP-4210-86	049525	Slinger Ring
3	BP-4210-27	049004	Square-Ring
4	BP-4210-100	003210	Pump Block
5	BP-4210-104	065725	Tube
6	BP-4210-80	062335	By-Pass Stem Assembly
7	BP-4210-24	049001	Square Ring
8	BP-4210-103	022315	By-Pass Cover
9	BP-4210-25	049002	Square-Ring
10	BP-4210-12	063268	Strainer, 100 Mesh, Gasoline
	BP-4210-11		Strainer, 30 Mesh, Diesel
11	BP-4210-103	022900	Strainer Cover
12	BP-4210-08	067030	Vane
13	BP-4210-26	049003	Square-Ring
14	BP-4210-101	003065	Pump Base
15	BP-4210-28	066655	Check Valve Assembly (items 16–23)

Item	SVI part #	OEM #	Description
16	call for details	029155	Valve Guide
	call for details	029005	Valve Guide, 1800R
17	call for details	068680	Washer
18	call for details	038980	Hex Jam Nut
19	call for details	068650	Washer
20	call for details	024356	Valve Disc
21	call for details	022271	Check Valve Cover Assembly
22	call for details	042370	Cotter Pin
23	call for details	062620	Valve Stem w/Relief Valve
	call for details	*062365	Relief Valve
24	BP-4210-23	054024	Seal Kit (items 25–30)
25	BP-4210-36	048956	O-Ring
26	BP-4210-35	048820	Floating Seal Ring-Carbon
27	BP-4210-34	049510	Rotating Seal Ring
28	BP-4210-33	048941	O-Ring .612 ID
29	BP-4210-32	067210	Washer
30	BP-4210-31	057956	Spring
31	BP-4210-22	051475	Rotor
32	BP-4210-21	031285	Key, 70 Series
33	BP-4210-102	003490	Pump Cover



**Series 70 & 1820 Installation Parts** (pictured right)

Item	SVI part #	OEM #	Description
1	BP-4218-02	003835	Install-A-Socket
2	call for details	021970	2" Coupling
3	call for details	045010	2" x 40" Pipe (Underground)
4	call for details	045535	2" x 30" Pipe (Pedestal)
5	call for details	044380	1" x 32-1/2" Suction Pipe
		R11495 108	1" x 32-1/2" Suction Pipe
6	call for details	053320	Set Screws
7	call for details	066445	1" Union
		K07797	1" Union
8	call for details	003055	Pedestal Base

**Optional Kits for Series 70 and 1800 Pumps**

SVI part #	OEM #	Description
call for details	032765	Kit, Wall-Mount 1820/1820R
call for details	032711	Kit, Filter - 1820R (for use with wall mount kit 032765)
call for details	032712	Kit, Filter 1820 (For use with wall mount kit 032765)
call for details	032814	Kit, Filter 1820/1820R Diesel/Gas
BP-4210-01	032888	Kit, Repair 70/1800
call for details	032701	Kit, Vacuum Breaker 1820R
BP-4210-59	032700	Kit, Vacuum Breaker Tubing and Fittings (Does not include Vacuum Breaker)
call for details	047575	Kit, Vapor Recovery (72VR)
BP-4212-02	032889	Register Rebuild Kit, 1860
BP-4212-03	033026	Register Rebuild Kit, 4860

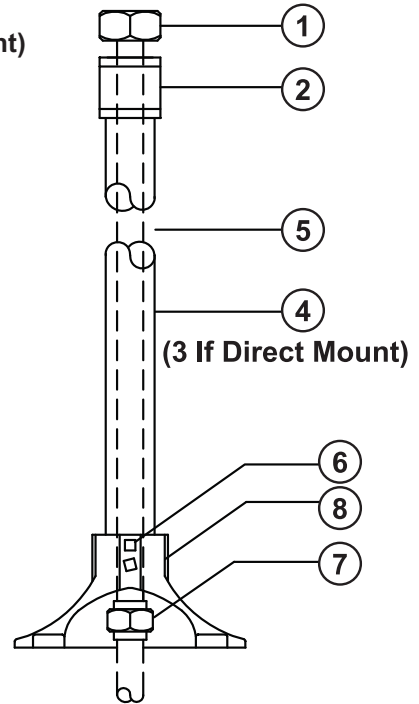

**Series 70, 1800 and 390 Repair Kit** (pictured below)

Item	SVI part #	OEM #	Description
	<b>BP-4210-01</b>	<b>032888</b>	<b>Repair Kit for Series 70, 1800 &amp; 390</b>
1	BP-4210-27	049004	O-Ring, Square Cut, #7-230
2	BP-4210-21	031285	Rotor Key
3	BP-4210-22	051475	Rotor
4	BP-4210-23	054024	Seal Kit, Series 70 & 1820
5	BP-4210-20	027055	Gasket
6	BP-4210-26	049003	O-Ring, Square Cut, #7-224
7	BP-4210-28	066655	Check Valve Assembly
8	BP-4210-24	049001	O-Ring, Square Cut, #7-214
9	BP-4210-25	049002	O-Ring, Square Cut, #7-218
10	BP-4210-08	067030	Vane - 1820

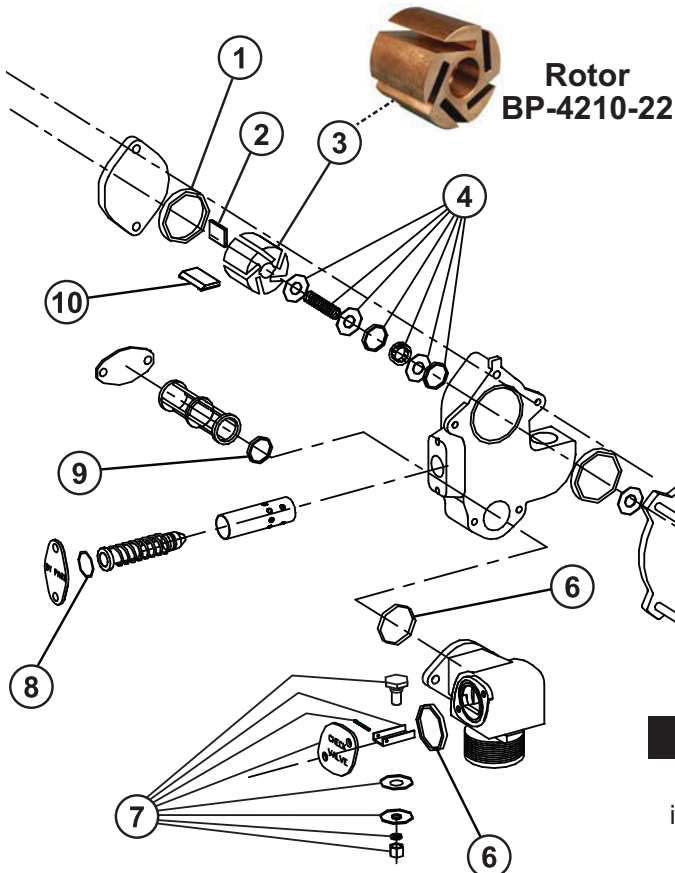

**\*Slimline 390 Pump**

Slimline 390 has same internal parts as 1800, with different housing.

## Model 1820 Register Setback and Switch Linkage Assembly Parts List

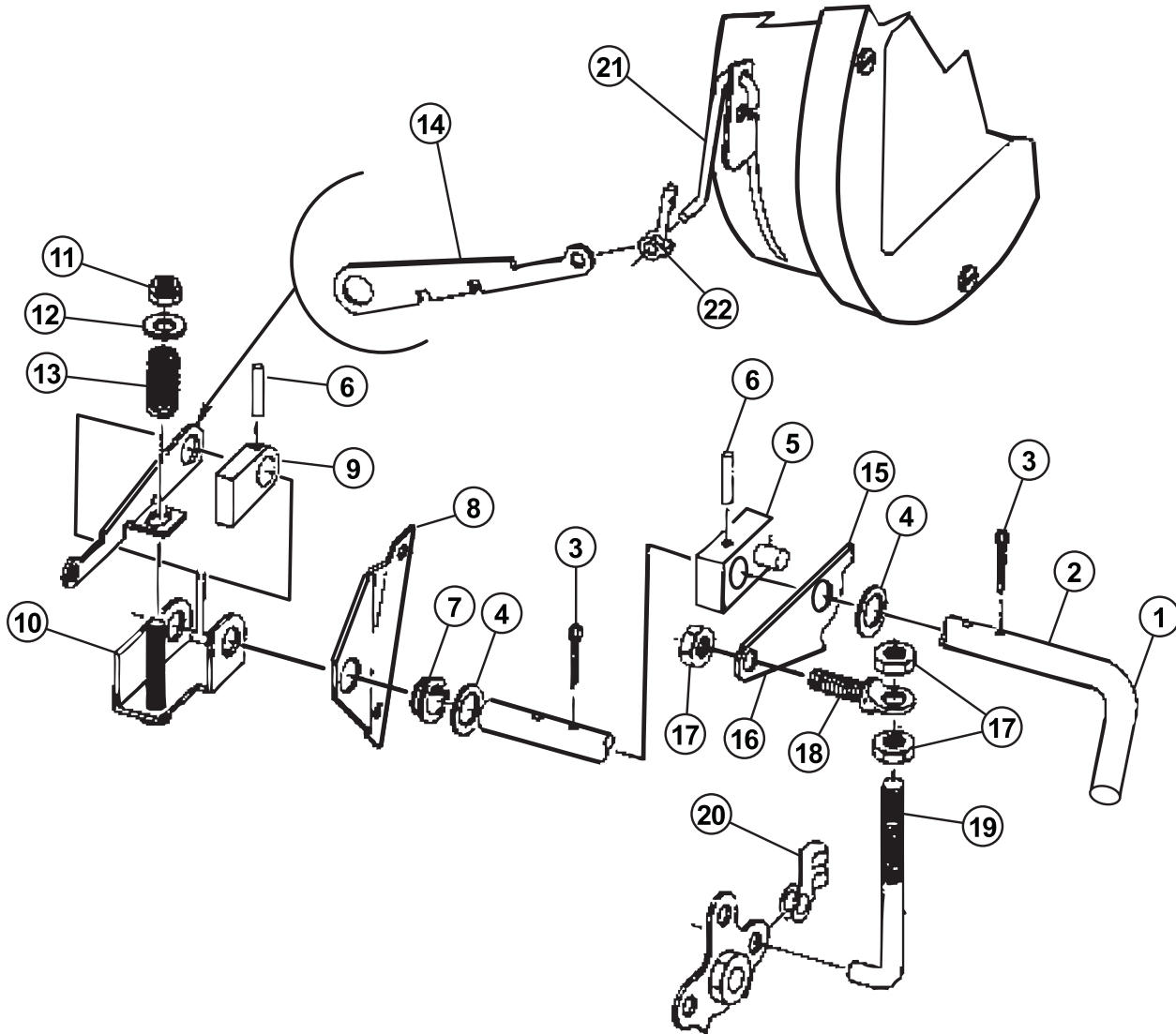

Item	SVI part #	OEM #	Description
1	call for details	054654	Control Shaft (incl. items 2-14)
2	call for details	054610	Control Shaft
3	call for details	042355	Cotter Pin
		K02125	Cotter Pin
4	call for details	068635	Washer
5	call for details	012520	Drive Block Assembly
6	call for details	042596	Driv-Lok Pin
		K53911	Driv-Lok Pin
7	call for details	039815	Nyliner Bearing
8	call for details	011870	Shaft Bracket
9	call for details	012641	Drive Block, Reset
10	call for details	024776	Reset Arm Driver Assembly

Item	SVI part #	OEM #	Description
11	call for details	038875	Hex Nut
12	call for details	067270	Washer
13	call for details	057925	Spring Reset
14	call for details	010827	Reset Arm
15	call for details	051206	Switch Rod Assembly (incl. items 16-19)
16	call for details	034155	Switch Lever, 1800
17	call for details	038905	Hex Lock Nut
18	call for details	051730	Adjusting Screw
19	call for details	050755	Switch Rod
20	call for details	021040	Throttle Clip - LH
21	BP-4210-79	034804	Reset Link
22	call for details	020935	Throttle Clip - RH



**Model 1820R**

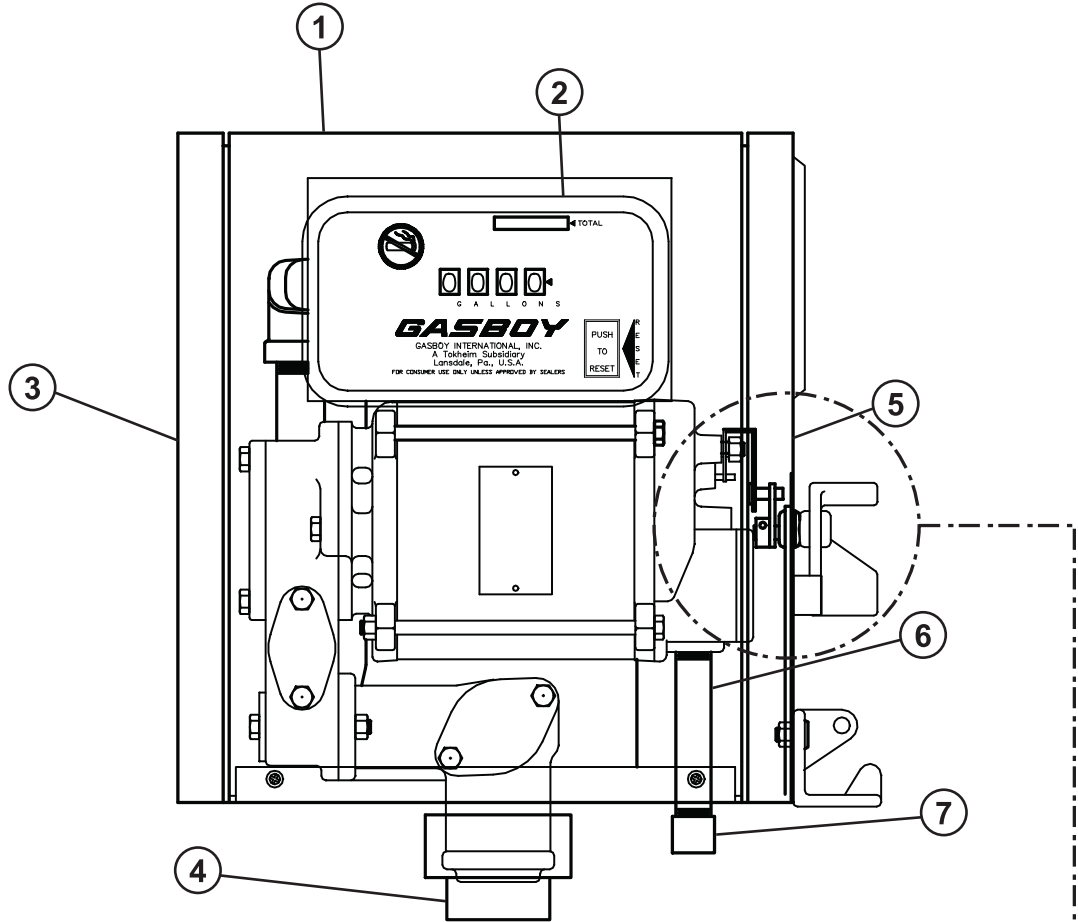

Item	SVI part #	OEM #	Description
1	call for details	022194	Cover-1820R, CRS
	call for details	022971	Cover-1820R, SS
2	call for details	012267	Bezel
3	call for details	022193	Panel Assembly-Left, CRS
		M04559A001	Panel Assembly-Left, CRS
	call for details	022970	Panel Assembly-Left, SS
		M04559A002	Panel Assembly-Left, SS
	call for details	022988	Panel Assembly-Left, CRS, Pulser
	M04559A003	Panel Assembly-Left, CRS, Pulser	
call for details	022979	Panel Assembly-Left, SS, Pulser	
	M04559A004	Panel Assembly-Left, SS, Pulser	
4	BP-4218-02	003835	Install-A-Socket
5	call for details	041384	Panel Assembly-Right, CRS
		M04560A001	Panel Assembly-Right, CRS
	call for details	041383	Panel Assembly-Right, SS
	M04560A002	Panel Assembly-Right, SS	
6	call for details	021374	Conduit 1/2 x 5
7	call for details	017931	Thread Protector 1/2" MNPT
8	call for details	017578	Cam Assembly
		M04446A002	Cam Assembly
9	call for details	033748	Switch Actuator Assembly
10	call for details	068080	Washer - 5/16 Plated
11	call for details	068281	Washer - Spring 7/16
12	call for details	051072	Switch Arm Assembly
13	call for details	063209	Eccentric Stop
14	call for details	052314	Flathead Screw
15	call for details	026575	Frame Assembly
		M04610A001	Frame Assembly

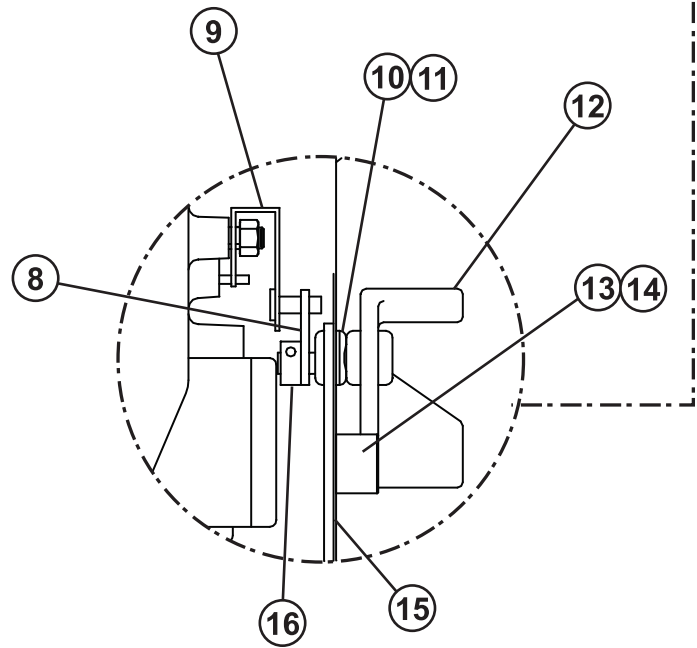

16	call for details	053516	Set Screw, Soc. Hd., 10-32 x 1/4 HF
17	call for details	040754	Panel-Back, CRS (not shown)
		M04558B001	Panel-Back, CRS (not shown)
	call for details	040811	Panel-Back, SS (not shown)
		M04558B002	Panel-Back, SS (not shown)

P  
a  
g  
e  
20

## Model 1820R Pulser and Junction Box Assemblies

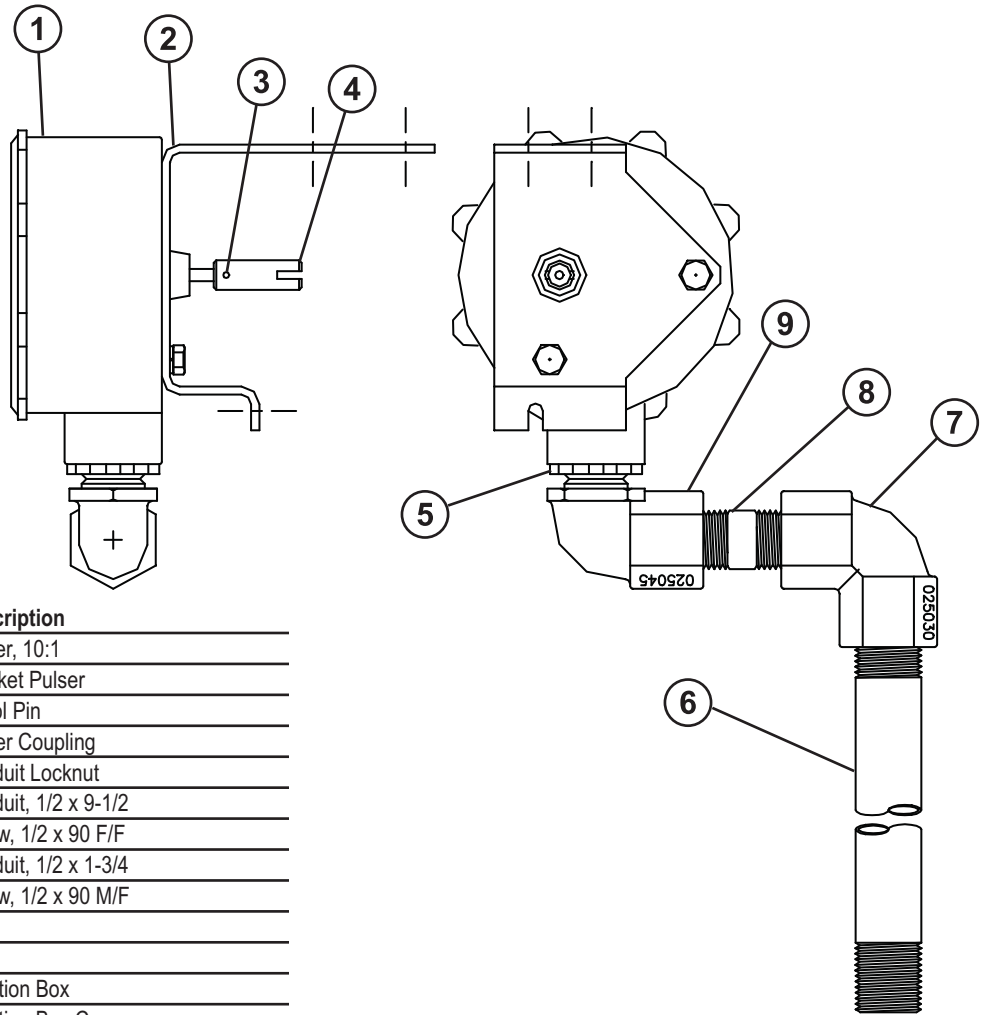

Item	SVI part #	OEM #	Description
1	call for details	021788	Pulser, 10:1
2	call for details	014646	Bracket Pulser
3	call for details	043211	Spirol Pin
4	call for details	021943	Pulser Coupling
5	call for details	039130	Conduit Locknut
6	call for details	021378	Conduit, 1/2 x 9-1/2
7	call for details	025030	Elbow, 1/2 x 90 F/F
8	call for details	021532	Conduit, 1/2 x 1-3/4
9	call for details	025045	Elbow, 1/2 x 90 M/F

**NOT SHOWN:**

call for details	003340	Junction Box
call for details	003515	Junction Box Cover
call for details	067506	Washer, Brass Cupped
	067500	Washer, Brass Cupped
call for details	052976	Screw, 10-32 x 3/8 Slotted Ground



## Model 74 & 71 Direct Drive Motor-Pump Assembly

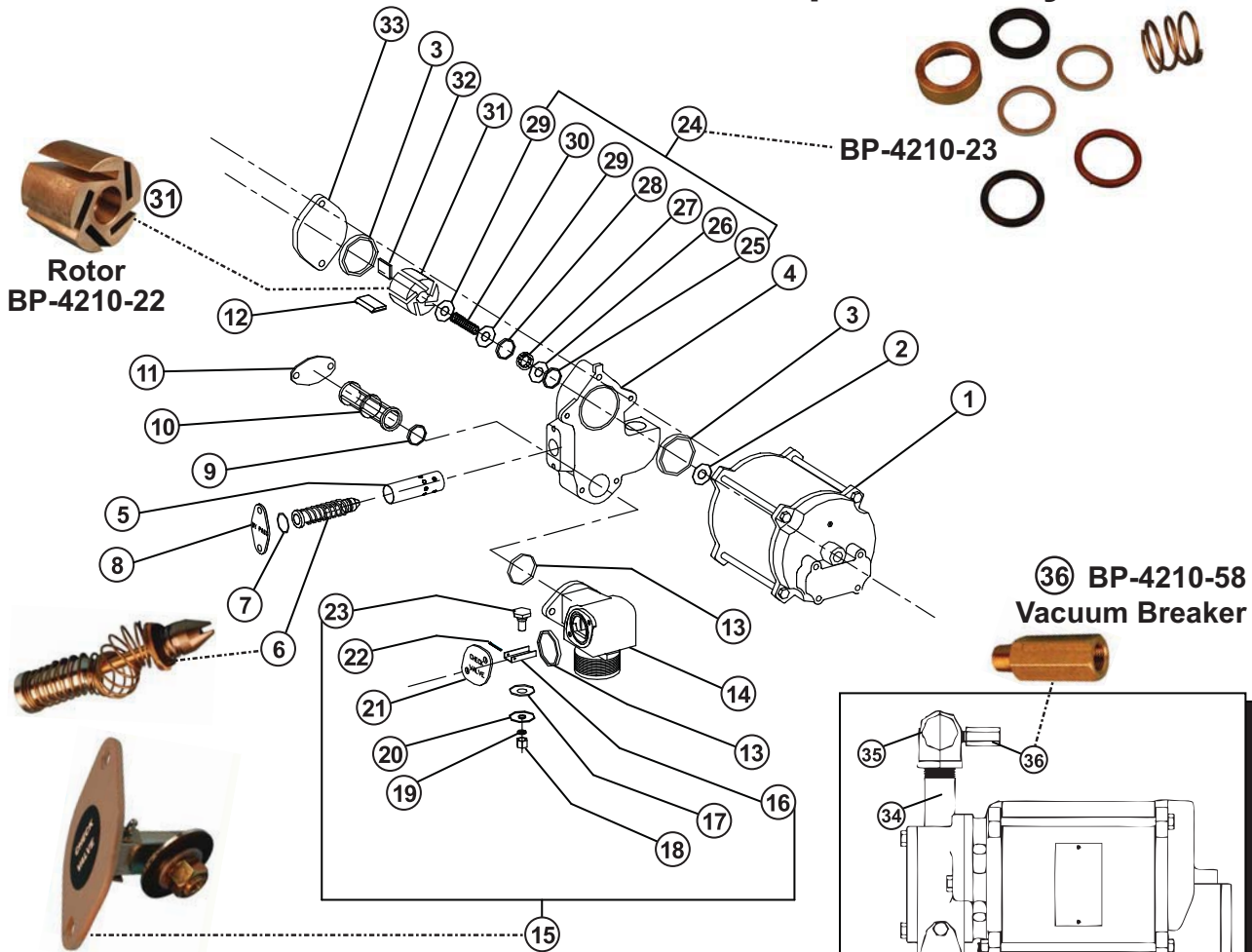

Item	SVI part #	OEM #	Description
1	BP-4218-20R	F37332	Motor, 115V, 60 Cycle, 70 Series (Red) (use suffix 20B for beige and 20W for white)
	BP-4218-24	F37616	Motor, 230V, 50 cycle, 70 Series
	BP-4218-21	F37325	Motor, 230V, 50/60 cycle, 70 Series
2	BP-4210-86	049525	Slinger Ring
3	BP-4210-27	049004	Square-Ring
4	BP-4210-100	003210	Pump Block
5	BP-4210-104	065725	Tube
6	BP-4210-80	062335	By-Pass Stem Assembly
7	BP-4210-24	049001	Square Ring
8	BP-4210-103	022315	By-Pass Cover
9	BP-4210-25	049002	Square-Ring
10	BP-4210-12	063268	Strainer, 100 Mesh, Gasoline
	BP-4210-11	063266	Strainer, 30 Mesh, Diesel
11	BP-4210-103	022900	Strainer Cover
12	BP-4210-08	067030	Vane
13	BP-4210-26	049003	Square-Ring
14	BP-4210-101	003065	Pump Base
15	BP-4210-28	066655	Check Valve Assembly (items 16-23)
16	call for details	029155	Valve Guide
	call for details	029005	Valve Guide, 1800R
17	call for details	068680	Washer
18	call for details	038980	Hex Jam Nut
19	call for details	068650	Washer

Item	SVI part #	OEM #	Description
20	call for details	024356	Valve Disc
21	call for details	022271	Check Valve Cover Assembly
22	call for details	042370	Cotter Pin
23	call for details	062620	Valve Stem w/Relief Valve
	call for details	*062365	Relief Valve
24	BP-4210-23	054024	Seal Group (items 25-30)
25	BP-4210-36	048956	O-Ring
26	BP-4210-35	048820	Floating Seal Ring-Carbon
27	BP-4210-34	049510	Rotating Seal Ring
28	BP-4210-33	048941	O-Ring .612 ID
29	BP-4210-32	067210	Washer
30	BP-4210-31	057956	Spring
31	BP-4210-22	051475	Rotor
32	BP-4210-21	031285	Key, 70 Series
33	BP-4210-102	003490	Pump Cover
34	call for details	R11496-106	Pipe, 3/4" x 6-7/8
35	BP-4210-105	024934	Elbow
36	BP-4210-58	066534	Vacuum Breaker

## Pulser Assembly - Model 71 OEM #049912

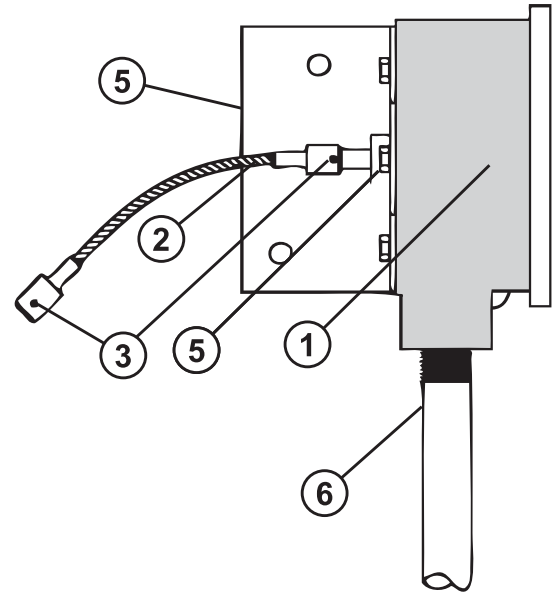
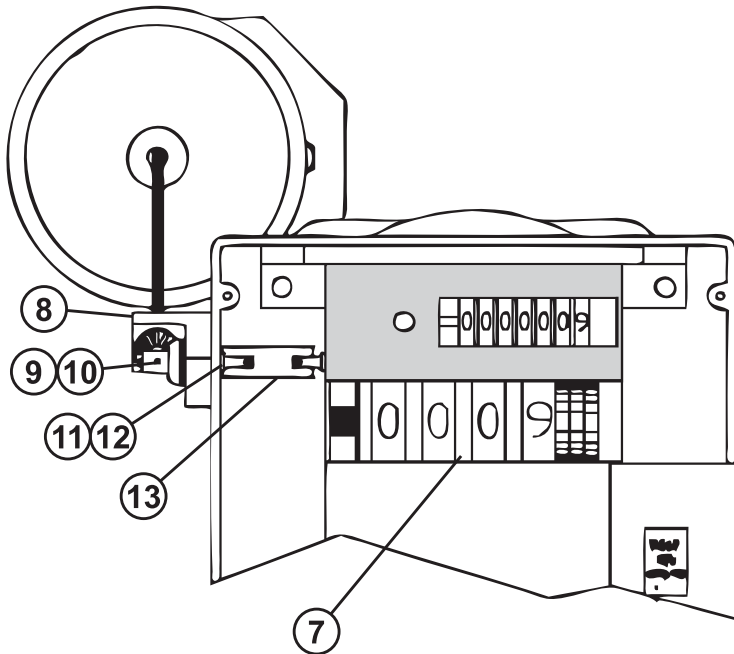

Item	SVI part #	OEM #	Description
1	call for details	021788	Pulser, 10:1 VR
2	call for details	017377	Pulser Drive Cable
3	call for details	K02137-26	Cotter Pin 1/16 x 5/8
4	call for details	K05287	Screw 1/4-20 x 1/2 HHC
5	call for details	015919	Bracket, Pulser
6	call for details	021517	Conduit, 1/2 x 11
7	call for details		Complete Register Assembly
	BP-4210-30KP	S00758	Meter Register Assembly (w/ Dial Glass)
	BP-4210-30LS	S00766	Reg. Assy., Ext. Shaft/Pul (w/ Dial Glass)
8	call for details	027049	Block & Miter Gear Assy. (Does not include items 9 & 10)

Item	SVI part #	OEM #	Description
9	call for details	027048	Miter Gear
10	call for details	042431	Groove Pin, 1/16 x 1/4
11	call for details	054035	Pulser Drive Shaft (see note below)
12	call for details	043210	Roll Pin, 0.052 Dia. x 3/8" Long
13	call for details	054036	Pulser Drive Coupling

**Note:** For units with serial number 490100 and below, you must also order OEM part number 054036 pulser drive coupling and 043210 roll pin.

## Inlet Assembly - Model 71

Item	SVI part #	OEM #	Description
1	call for details	003560	Elbow, Flanged, 1"
2	BP-4210-20	M05618B001	Gasket, Inlet/Outlet
3	call for details	R11935-20	Pipe, TBE, 1 x 1-1/2
4	call for details	067034	Solenoid Valve, 1" Skinner 2-Stg. 115V
	call for details	067036	Solenoid Valve, 1" Skinner 2-Stg. 230V
5	call for details	R11495-21	Pipe, TBE, 1 x 5
6	call for details	025045	Elbow, Conduit, 1/2 x 90, M/F
7	call for details	N16771-21	Pipe, TBE, 1/2 x 1-1/8
8	call for details	025030	Elbow, Conduit, 1/2 x 90 F/F
9	call for details	N16289-20	1/2" UNY Explosion-proof Conduit Union

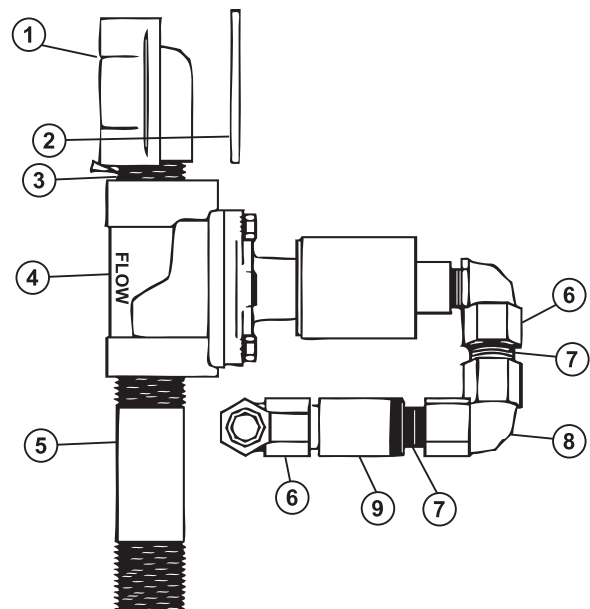



## Bearing Plate and Switch Assembly - Model 71

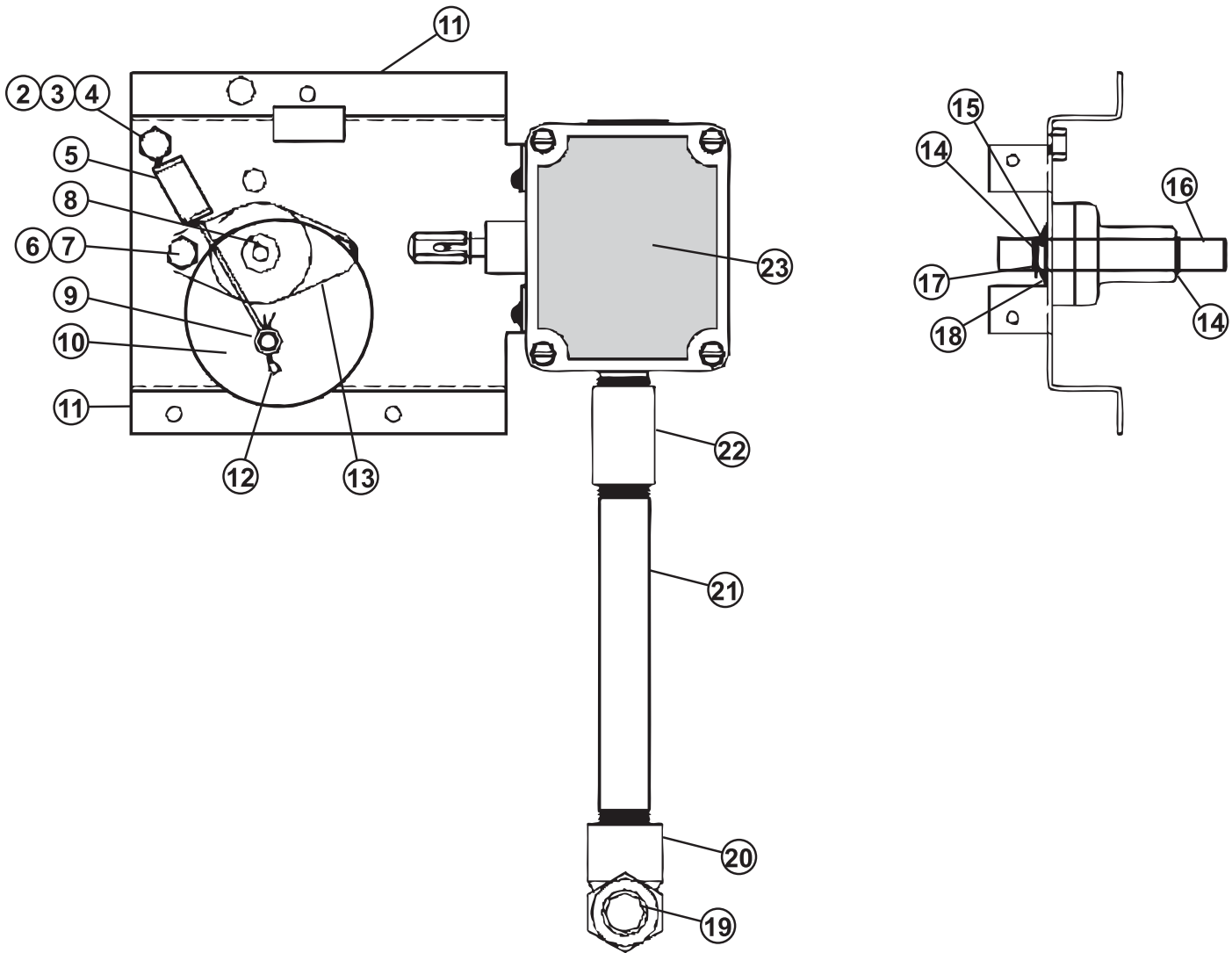

Item	SVI part #	OEM #	Description
1	call for details	049910	Plate-Bearing Assy. (incl. items 2-18)
2	call for details	Q12068-06	Nut, 5/16 x 18
3	call for details	C08914	Nylon Bushing
4	call for details	K03782	Screw, 5/16-18 x 1-3/4 HHC
5	call for details	029358	Handle Spring
6	call for details	K73278-28	Lockwasher, 5/16
7	call for details	K51194	Screw, 5/16-18 x 5/8 HHC
8	call for details	042657	Roll Pin, 1/8 x 1-3/8
9	call for details	C08913	Nylon Bushing
10	call for details	046054	Cam
11	call for details	015920	Switch Bracket
12	call for details	K02125	Cotter Pin

Item	SVI part #	OEM #	Description
13	call for details	003184	Bearing
14	call for details	K76238-20	Retaining Ring
15	call for details	011958	Bearing, Nyliner
16	call for details	054447	Shaft, Start
17	call for details	067109	Brass Washer
18	call for details	068951	Spring Washer
19	call for details	N16289-20	1/2" UNY Explosion-proof Conduit Union
20	call for details	025045	Elbow, Conduit, 1/2 x 90 M/F
21	call for details	021401	Conduit, 1/2 x 7
22	call for details	021986	Coupling
23	call for details	064440	Switch Housing/Wire Assembly
24	call for details	*064466	Switch (subpart within 064440 Assy.)

## Model 71 Discharge Assembly Standard - Bottom

## Model 71 Discharge Assembly Rear, Optional

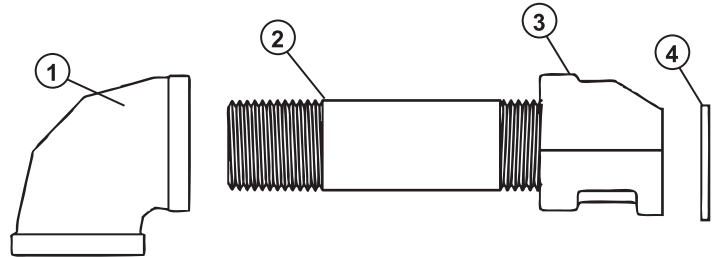
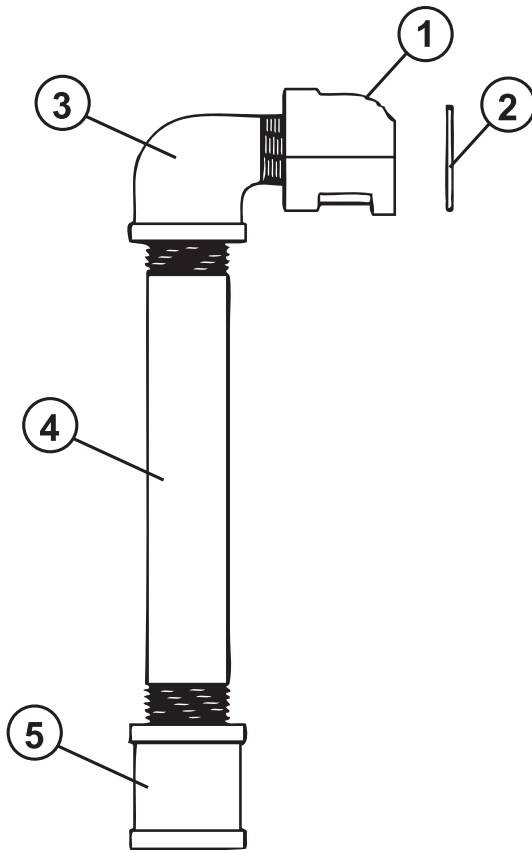

Item	SVI part #	OEM #	Description
1	call for details	024895	Elbow, 1 x 90
2	call for details	R11495-21	Pipe, TBE 1 x 5
3	call for details	003560	Elbow, Flanged, 1"
4	BP-4210-20	M05618B001	Gasket, Inlet/Outlet

Item	SVI part #	OEM #	Description
1	call for details	003650	Flange, 1" T
2	BP-4210-20	M05618B001	Gasket, Inlet/Outlet
3	call for details	K02321-20	Elbow, Street
4	call for details	R11495-94	Pipe, TBE 1 x 9
5	call for details	021955	Coupling, 1" Black Mall.

## Model 71 - Optional Accessories - Parts

Item	SVI part #	OEM #	Description
1	BP-4218-21	F37325	Motor, 50/60 Cycle, 230 VAC
2	call for details	032118	Filter Kit
3	call for details	032689	Pulser Kit, 10:1 Ratio, Gallon/Liter
4	call for details	038573	Nozzle, Automatic, Unleaded, M. Carder
5	call for details	038574	Nozzle, Automatic, Leaded, M. Carder
6	call for details	089700	Mounting Pedestal
7	call for details	089702	Mounting Pedestal, Stainless Steel
8	call for details	015764	Mounting Bracket for Tank Mounted Register
9	call for details	041812	Panel, Sides/Back, Stainless Steel
10	call for details	041813	Door, Front, Stainless Steel
11	call for details	041814	Cover, Top, Stainless Steel
12	call for details	041815	Base, Stainless Steel



### Gasboy Quick Reference

<p><b>BP-4210-02</b> Repair Kit - 20 Series (old style)</p>  <p>For new style, order BP-4210-02N</p>	<p><b>BP-4210-01</b> Repair Kit for 1800, 70, 390</p> 	<p><b>BP-4211-03</b> Repair Kit for 60 Series</p> 
<p><b>BP-4210-29</b> Seal Kit (old style) - 20 series</p> 	<p><b>BP-4210-29N</b> Seal Kit (new style) - 20 series</p> 	<p><b>BP-4211-13</b> Seal Kit - 60 Series</p> 
<p><b>BP-4210-20</b> Gasket (OEM #M05618B001 / 027055)</p> 	<p><b>BP-4210-07-5</b> Vaness (5-pack) - Series 20-26</p> 	<p><b>BP-4211-07</b> Vane - 60 Series</p> 
<p><b>BP-4210-56</b> Rotor for 20 Series</p> 	<p><b>BP-4211-04</b> Rotor - 60 Series</p> 	<p><b>BP-4210-22</b> Rotor for 70 Series, 1800 &amp; 390</p> 

**Gasboy Quick Reference**

**BP-4210-28**  
Check Valve Assy.



**BP-4210-30KP**  
Meter Register with Dial Glass

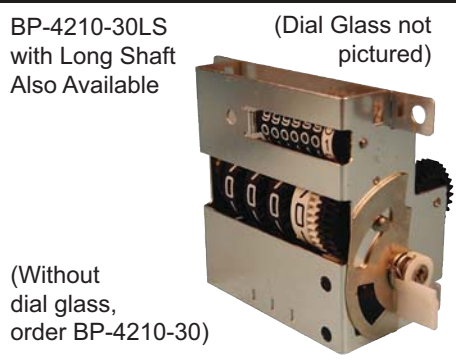

**BP-4211-36**  
Brush/Switch Replacement Kit



**BP-4210-23**  
Seal Kit for 70 Series & 1820



**BP-4217-05**  
Repair Kit for 1720A, 1520 & 787



**BP-4218-07A**  
Switch & Protector 4 Terminal



**BP-4210-60**  
Check Valve Retrofit Kits



**BP-4212-21**  
Left Wheel for 1860 Register



**BP-4212-20**  
Center Wheel for 1860 Register



**BP-4212-04**  
Meter Bezel - 4860



**BP-4212-40**  
Meter Bezel - Round (70 Series)



**BP-4210-80**  
Bypass Stem Assembly 70/1800





### Gasboy Quick Reference

**BP-4210-68**

Nozzle Hanger 1820



**BP-4212-34**

Round Dial Mask - Gallons



**BP-4212-73**

Toggle Switch for Motor 70 Series



**BP-4214-07**

Vane - Carbon



**BP-4212-02**

Repair Kit for 1860 Register



**BP-4217-10**

Repair Kit for 1700 Series



**BP-4218-30R**

Nozzle Boot - 70 Series (Red)



**BP-4210-58**

Vacuum Breaker Assembly



**BP-4211-23**

Vacuum Breaker Assembly



**BP-4218-20**

Motor for 70 Series

(Available in Red, White or Beige)



1/3 HP Motor 60Hz. 48 Frame

**BP-4218-28**

Motor for 1800 Series



1/3 HP Motor 60Hz. 48 Frame

**BP-4218-25 and BP-4218-26**

60 Hz. Motors for 20 Series



BP-4218-25 Motor for Models 25 & 250  
BP-4218-26 Motor for Models 26, 27, 28

## Gasboy Quick Reference

**BP-4210-67**  
Check Valve Assembly



**BP-4211-08**  
Check Valve - 60 Series



**BP-4210-04**  
Seal Kit - 600 Series



**BP-4212-17**  
Reset Bearing



**BP-4212-18**  
Reset Button



**BP-4212-03**  
Repair Kit for 4860 Register



**TERMS AND CONDITIONS OF THE  
SALES ORDER  
FOR SVI INTERNATIONAL, INC.**

1. **GENERAL.** The terms and conditions of sales order outlined herein shall apply to the sale by SVI INTERNATIONAL, INC. (hereinafter referred to as "Company") of the items described on the facing page (hereinafter referred to as "Merchandise") to Purchaser.
2. **DELIVERY.** Delivery shall be deemed to be complete when the Merchandise has been shipped F.O.B. Company's plants in DeKalb, Illinois, Duarte, California; and Baltimore, Maryland ("Company's plants"). Shipments are subject to delays from causes or contingencies beyond the reasonable control of the Company. When otherwise not specified, shipments will be made in standard containers via carrier which, in the judgment of the Company, will result in the most practical method. Title and right of possession will pass to the Purchaser upon receipt by the carrier at the shipping point. If a customer of the Company should specify a specific carrier's method of shipment (i.e. UPS Next Day Air) and that carrier does not perform to the customer's expectations, freight credit to a customer's account will not be issued unless the Company can first obtain a credit.
3. **RISK OF LOSS.** Identification of the Merchandise under Uniform Commercial Code (hereinafter referred to as "UCC") Section 2-501 shall take place at the moment of shipment F.O.B. Company's plants. Risk of loss shall pass to the Purchaser when the Merchandise is shipped from the Company's plants.
4. **TITLE.** Title to the merchandise shall transfer to the Purchaser when the Merchandise is shipped from the Company's plants.
5. **WARRANTIES.** The Company guarantees its products to be free from defects in workmanship and raw materials for a period of one year from date of purchase. THIS WARRANTY IS EXPRESSLY IN LIEU OF ANY AND ALL WARRANTIES EXPRESS OR IMPLIED. COMPANY DOES NOT WARRANT THE MERCHANDISE IS MERCHANTABLE OR FIT FOR ANY PARTICULAR PURPOSE. Company's liability for breach of the terms of this Agreement, including any warranty, is limited to either refund of the invoice price of the Merchandise or at Company's option, replacement of the Merchandise free of charge, including transportation charges but not including the cost of labor. Purchaser has not relied on any statement or upon the conduct of Company with respect to the prospective use of the merchandise. Company shall not be liable for and Purchaser waives any and all claims for any loss or damage, directly or indirectly, arising from the use of the Merchandise and for punitive, incidental or consequential damages, including, but not limited to, damages to property, for loss of use, loss of time, loss of profit or loss of income. The Company does not authorize the sale of our products under any other warranty, expressed or implied.
6. **SETOFF.** All claims for money due or to become due from the Company shall be subject to deduction by the Company for any setoff or counterclaim arising out of this or any other claims of the Company or its affiliated companies, whether such setoff or counterclaim arose before or after any assignment by Purchaser.
7. **INDEMNIFICATION.** Purchaser agrees to indemnify the Company and hold it harmless from and against all claims, liability, loss, damage or expense, including reasonable counsel fees, arising from or by reason of any modifications or alterations made by Purchaser. If a customer of the Company modifies or alters any part, in any manner whatsoever, or uses any part in departure from recommended performance specifications, said customer agrees to indemnify and hold the Company harmless from and against all liability and expenses based on damage to property or injury to or death of any person arising out of or attributable to such modified or altered part. Further, the Company will not accept any such modified or altered part for credit to a customer's account.
8. **FREIGHT POLICY.** Freight charges on individual orders less than \$3,000 in net value are prepaid and added to invoice or collect F.O.B. shipping point. Freight charges (standard ground service and continental US only) on individual orders more than \$3,000 net value are paid by the Company F.O.B. shipping point. Note: customers with C.O.D. terms are responsible for all carrier C.O.D. fees regardless of order net value.
9. **RETURN POLICY.** To return parts for credit or inspection Purchaser must first contact the Company to obtain a Return Goods Authorization number (RGA#). Once Purchaser has obtained an RGA# the parts can be returned freight prepaid only. The RGA# must be on the outside of the container in a highly visible location. All parts must be returned freight prepaid and the shipment must include a letter of explanation giving the specific reason for return including details as to the conditions under which the part or parts operated. Note: parts returned without an RGA#, freight collect or without written explanation may be refused. Parts which have been used in any way or manner, including any installation or incorporation into a lift or hoist, shall NOT be eligible for return whether or not an RGA has been assigned.
10. **RESTOCK CHARGE.** Returns are subject to up to twenty-five (25%) restocking charge. Refusals are subject to the same restocking charge plus the cost of outbound and return freight charges and/or fees incurred by the Company due to shipment refusal.
11. **PRICES AND PAYMENTS.** All prices are subject to change without notice. All prices are F.O.B. shipping point. The Company standard terms are net 30 days, C.O.D. company check, C.O.D. cash, VISA, MasterCard, Discover or American Express. However, if in the judgment of the Company, the financial condition of the Purchaser at any time does not justify shipment according to standard terms of payment, the Company may require full or partial payment in advance.
12. **INTERPRETATION.** This sales order is intended by the parties as a complete and exclusive statement of the terms of their agreement. It supersedes all prior agreements, written or oral. No course of prior dealings between the parties and no usage of the trade shall be relevant to supplement or explain any terms used in this sales order. Acceptance or acquiescence in a course of performance rendered under this purchase order shall not be relevant to determine the meaning of this sales order even though the accepting or acquiescing party has knowledge of the nature of the performance and opportunity for objection. Whenever a term defined by the UCC is used in this sales order the definition contained in the UCC shall control.
13. **MODIFICATION.** This sales order can be modified or rescinded only by a writing signed by both parties.
14. **WAIVER.** No claim or right arising out of a breach of this sales order can be discharged in whole or in part by a waiver or renunciation of the claim or right unless such waiver or renunciation is supported by consideration and is in writing signed by the aggrieved party.
15. **ASSIGNMENT.** No right or interest in this sales order shall be assigned by either party without the written consent of the other and no delegation of any obligation owed, or of the performance of any obligation by either the Company or Purchaser shall be made without the written consent of the other party. Any attempted assignment or delegation not made in conformity with this paragraph shall be wholly void and totally ineffective for all purposes.
16. **TIME TO PERFORM AND BRING ACTION.** Time is of the essence of this sales order. Any action for breach of this sales order shall be commenced within two (2) years after the cause of action has accrued. Any party who loses any litigation shall reimburse the other party for costs including reasonable attorneys fees. The exclusive jurisdiction for any legal action shall be the Circuit Court of DeKalb County, Illinois.
17. **APPLICABLE LAW.** This sales order shall be governed by the UCC of Illinois as effective and in force on the date of this sales order.

***Offering the Best in Automotive Lift Repair Parts and More!***

---

Auto Lift Cables • Auto Lift Parts • Brake Lathe Repair Parts

Compressed Air Repair Parts • Exhaust System Products • Fluid Delivery Repair Parts

Lubrication Equipment Repair Parts • Repair Parts for Gasboy Consumer Series

Service Station Pump and Tank Products • SVI Misc Auto Lift Products and Catalogs

Tire Changer Repair Parts • Vehicle Lifting Systems • Wheel Balancer Accessories

---

***Serving the Industry Since 1977 • Same-Day Shipping***



**SVI International, Inc.**

**(800) 321-8173 • fax: (800) 899-1784**

155 Harvestore Drive • DeKalb, IL 60115

**[www.sviinternational.com](http://www.sviinternational.com)**

**BALTIMORE • CHICAGO • LOS ANGELES**