

# Gasboy Consumer Products

R E P A I R P A R T S



**(800) 321-8173 • fax: (800) 899-1784**

155 Harvestore Drive • DeKalb, IL 60115

**[www.sviinternational.com](http://www.sviinternational.com)**

BALTIMORE • CHICAGO • LOS ANGELES

Repair Parts for:  
Gasboy  
Consumer  
Products  
PRC4210

Repair Parts for: Gasboy Consumer Products

# 1200 Series - Rotary Register Hand Pump

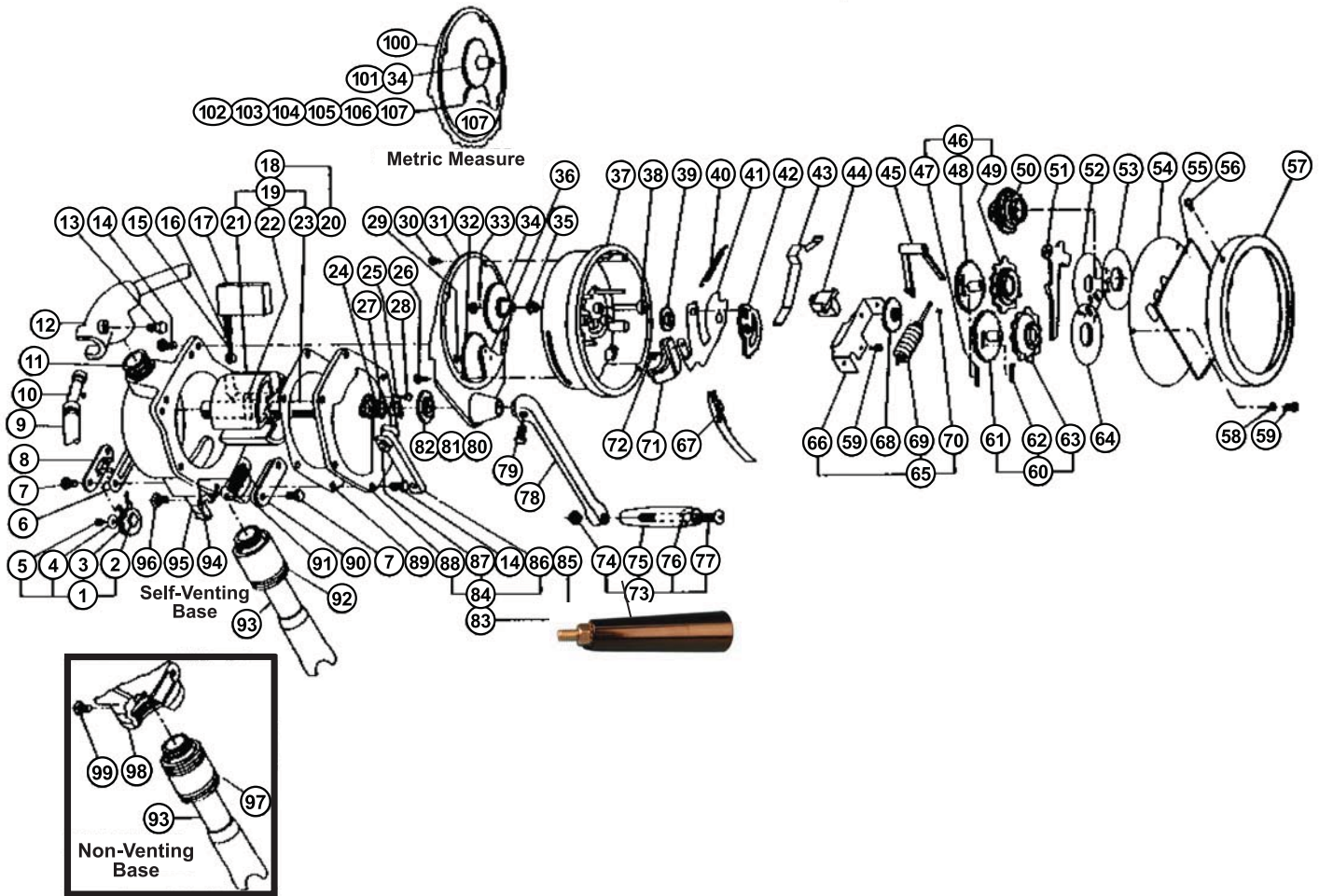

Item	SVI part #	OEM #	Description
1	BP-4214-04	066670	Check Valve Assembly (incl. 2-5)
2	BP-4214-04D	012760	Check Valve Body
3	BP-4214-04C	024341	Valve Disc
4	BP-4214-04B	067315	Washer
5	BP-4214-04A	052990	Screw
6	BP-4214-02	026995	Check Valve Gasket
7	BP-4214-21	051880	Screw
8	BP-4214-31	022376	Check Valve Cover
9	call for details	030460	Hose
10	BP-4214-13	000785	Nozzle, Plastic
	call for details	038455	Nozzle, Auto-Shut Off (Opt.)
	BP-4214-12	000784	Nozzle, Plastic, Unleaded (Opt.)
11	BP-4214-32	038035	Pipe Nipple
12	BP-4214-33	003880	Hose Drain Valve Body
13	BP-4211-23	066570	Vacuum Breaker
14	BP-4214-24	051895	Screw
15	BP-4214-08	042865	Guide Pin
16	BP-4214-06	058105	Spring
17	BP-4214-07	067015	Vane
18	call for details	055497	Shaft Rotor Assy., 1200RT (incl. 20-22)
19	call for details	055495	Shaft Rotor Assy., 1200 (incl. 21-23)
20	call for details	055361	Pump Shaft, 1200RT
21	BP-4214-34	003830	Rotor

Item	SVI part #	OEM #	Description
22	BP-4214-35	043240	Spirol Pin
23	BP-4214-36	054460	Pump Shaft, 1200
24	call for details	048955	O-Ring
25	BP-4214-37	022841	Seal Cover
26	call for details	051790	Screw
27	BP-4217-02	054160	Shaft Seal
28	BP-4214-38	052975	Screw
29	call for details	049406	Retaining Ring
30	call for details	052316	Screw
31	call for details	003037	Register Adapter, Gal.
32	call for details	028182	Idle Gear, Gal.
33	BP-4217-36	042290	Cotter Pin, Gal. or Ltr.
34	call for details	027656	Cluster Gear, Gal or Ltr.
	call for details	028453	Cluster Gear, Full Ltr.
35	BP-4210-40	014095	Bearing and Seal
36	call for details	055242	Shaft, Gal. or Ltr.
37	call for details	022662	Register Cover, Gal. or Ltr.
	call for details	030836	Register Cover, Full Ltr.
38	call for details	055692	Shaft and Gear, Gal. or Ltr.
	call for details	055268	Shaft and Gear, Full Ltr.
39	call for details	012085	Reset Lever Bearing
40	BP-4212-14	057895	Reset Lever Spring
41	call for details	033821	Reset Lever

(Parts List continues on following page)



1200 Series - Rotary Register Hand Pump

Table with 4 columns: Item, SVI part #, OEM #, Description. Rows 42-75.

Table with 4 columns: Item, SVI part #, OEM #, Description. Rows 76-108. Includes a note about gasket replacement.

## 1200 Series - Rotary Counter Hand Pump

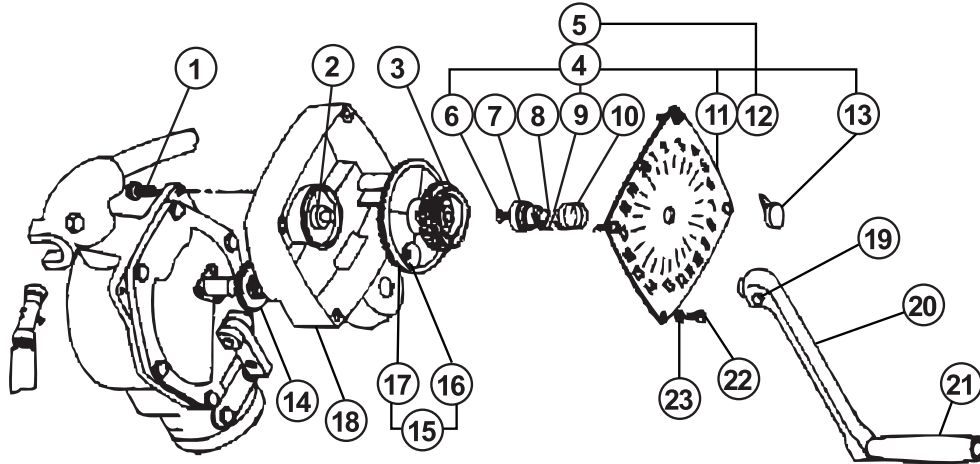

Item	SVI part #	OEM #	Description
1	BP-4214-24	051895	Screw
2	call for details	068635	Washer
3	call for details	027805	Counter Drive Gear
4	call for details	023890	Dial Assy., US, IMP Non-Totalizer (incl. 6-11, 14)
5	call for details	023905	Dial Assy., Ltr., Non-Totalizer (incl. 6-10, 12-14)
6	BP-4214-19	052735	Screw
7	BP-4214-18	047395	Pointer Hub
8	BP-4214-17	058120	Zero Stop Spring
9	BP-4214-16	043420	Zero Stop Pin
10	BP-4214-15	057475	Clutch Spring
11	call for details	025555	Dial Face, Non-Totalizer
12	call for details	025720	Dial Face, Liter Non-Totalizer

Item	SVI part #	OEM #	Description
13	call for details	047380	Pointer
14	call for details	043450	Drive Pinion
15	call for details	024760	Drive Gear Assembly (incl. 16-17)
16	call for details	031165	Planetary Gear, Idler
17	call for details	027833	Drive Gear
18	call for details	021820	Counter Housing
19	BP-4214-24	051895	Screw
20	BP-4214-20	003530	Crank
21	BP-4214-14	033040	Knob Assembly
22	call for details	052840	Screw
23	call for details	067765	Fiber Washer

## 1200 Series - Discharge Spout and Positive Shut-Off Valve

### Discharge Spout

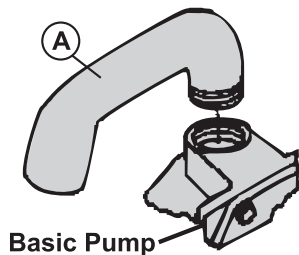

### Positive Shut-Off Valve

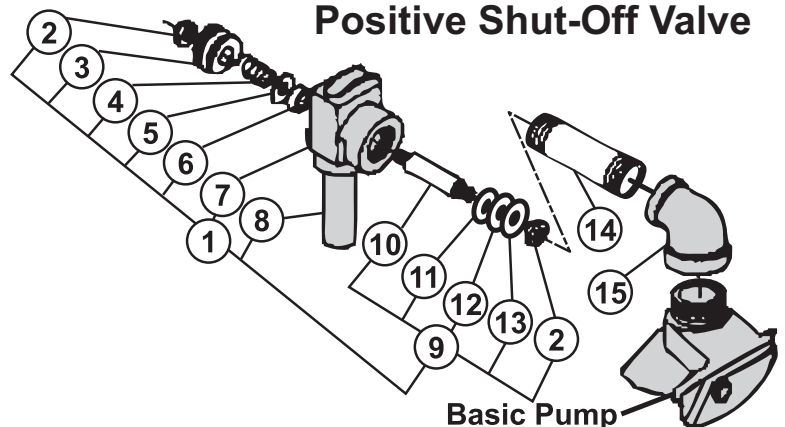

Item	SVI part #	OEM #	Description
A	call for details	003855	Spout
1	call for details	025870	Nozzle Assembly (incl. 2-13)
2	call for details	038875	Lock Nut
3	call for details	032905	Knob
4	call for details	057190	Spring
5	call for details	067285	Washer
6	call for details	023230	U-Cup
7	call for details	003215	Body

Item	SVI part #	OEM #	Description
8	call for details	057145	Spout
9	call for details	062260	Stem Assembly (incl. 2, 10-13)
10	call for details	062215	Stem
11	call for details	067270	Washer
12	call for details	067540	Rubber Disc
13	call for details	068530	Washer
14	call for details	044080	Pipe Nipple
15	call for details	024925	Pipe Reducing Elbow



## 1200 Series Drain Tray Assembly & Barrel Adapter, Models 1223, 1243

Item	SVI part #	OEM #	Description
1	call for details	044725	Pipe
2	call for details	021955	Pipe Coupling
3	call for details	044740	Pipe
4	call for details		Drain Tray Assembly, 1243 (obsolete)
5	call for details	034615	Lid, 1243
6	call for details	051610	Screen
7	call for details	039475	Push On Nut
8	call for details		Tray (obsolete)
9	call for details	044080	Pipe Nipple
10	call for details	049945	Rivet
11	call for details	053320	Set Screw
12	call for details	003020	Barrel Adapter, 1243
13	call for details	003450	Barrel Adapter, 1223

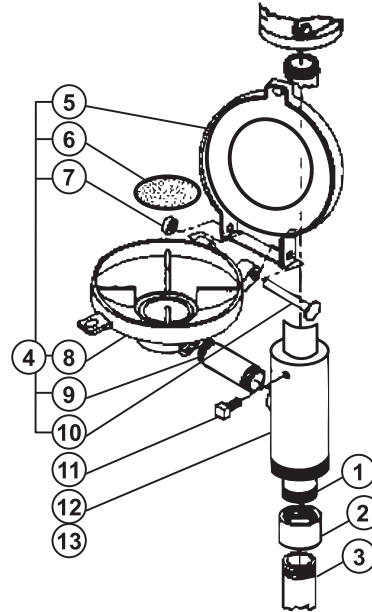

## 1200 Series Filters, Models 1230F, 1230RTF

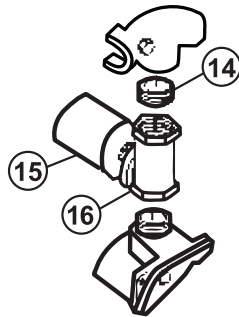

Item	SVI part #	OEM #	Description
14	call for details	026005	Filter
	call for details	017840	Filter Cap (if not using filter)
15	call for details	003044	Filter Adapter
16	BP-4214-32	038035	Pipe Nipple

## 1200RT Rotary Hand Pump with Unleaded Nozzle OEM #032852

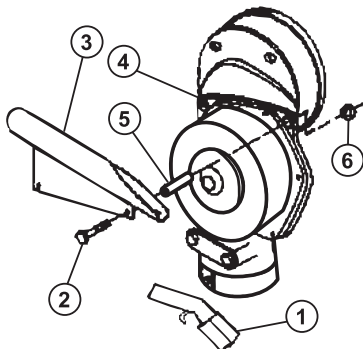

Item	SVI part #	OEM #	Description
1	BP-4214-12	000784	Unleaded Nozzle
2	call for details	051971	Screw, 5/16" x 18 x 4-1/4" HHC
3	call for details	013649	Nozzle Boot Assembly
4	BP-4214-24	051895	Screw, 5/16" x 18 x 3/4" HHC
5	call for details	056788	Spacer
6	call for details	038605	Nut, 5/16"-18 Hex Keys

## Optional Equipment

SVI part #	OEM #	Description
call for details	038455	Automatic Shut-Off Nozzle (Diesel only)
call for details	032852	Unleaded Nozzle Conversion Kit
call for details	032829	Standard Pump to Counter Model Conversion Kit, Gallon
call for details	032827	Standard Pump to Counter Model Conversion Kit, Liter

## 1200 Series Rotary Pumps - Repair Kit OEM #032885 (SVI # BP-4214-01)

Item	SVI part #	OEM #	Description
<b>KIT</b>	<b>BP-4214-01</b>	<b>032885</b>	<b>Repair Kit for 1200 Series</b>
1	BP-4214-04	066670	Check Valve Assembly
A	BP-4214-04A	052990	Screw
B	BP-4214-04B	067315	Washer
C	BP-4214-04C	024341	Valve Disc
D	BP-4214-04D	012760	Check Valve Body
2	BP-4214-02	026995	Check Valve Gasket
3	BP-4214-05	027355	Gasket Strainer Cover
4	BP-4214-09	026830	Gasket (see note)
5	BP-4214-10	049011	O-Ring (not shown)
6	call for details	C04033	Screw, 10-32 x 5/16 Pan Hd.
7	BP-4217-02	054160	Shaft Seal
8	BP-4214-03	048995	O-Ring, 11/16 x 7/8 Buna-N
9	BP-4214-07	067015	Vane, 1230
10	BP-4214-06	058105	Spring-Vane
11	BP-4214-08	042865	Guide Pin

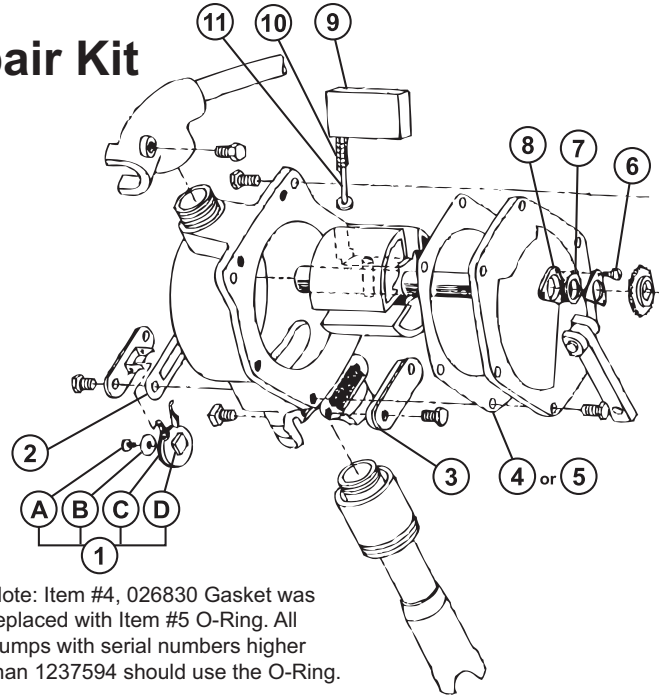

Note: Item #4, 026830 Gasket was replaced with Item #5 O-Ring. All pumps with serial numbers higher than 1237594 should use the O-Ring.

## Repair Kit for Models 1520A / 1720A / 786 / 787

SVI part #	OEM #	Description
<b>BP-4217-05</b>	<b>032694</b>	<b>Repair Kit for 15020A/1720A/786/787</b>
BP-4217-22	048252	Bearing
BP-4217-23	048249	Packing
BP-4217-24	048286	Retainer Spring
BP-4217-25	048272	Diaphragm
BP-4217-26	048288	Check Valve
BP-4217-27	048289	Valve Gasket
BP-4217-28	048243	O-Ring, Square Cut
BP-4217-29	048244	Diaphragm Washer



## 1620 / 1720 Diaphragm Pumps and 1420 / 1520 / 1520T Piston Pumps (pictured on following page)

Item	SVI part #	OEM #	Description
1	BP-4217-61	048911	Pump Body
2	BP-4217-23	048249	Packing
	call for details	040046	Packing, 1520T
3	BP-4217-22	048252	Bearing
4	BP-4217-51	048254	Bearing Plate
5	call for details	068155	1/4 Lockwasher
6	BP-4217-59	029398	Handle and Grip Assembly
7	BP-4217-53	034916	Connecting Link
8	call for details	042355	3/32 x 3/4 Lg. Cotter Pin
9	call for details	043020	Pin 1-15/32" long
10	call for details	048278	Valve Assembly
	call for details	066942	Valve Assembly, 1520T
11	BP-4217-27	048289	Valve Gasket
	call for details	054150	Small Valve Seal, 1520T
	call for details	054151	Large Valve Seal, 1520T
12	BP-4217-26	048288	Check Valve
	call for details	066941	Valve, 1520T
13	BP-4217-60	048247	Valve Plate

Item	SVI part #	OEM #	Description
14	call for details	048285	Valve Spring
15	BP-4217-24	048286	Spring Retainer
16	call for details	048287	Push-On Ring
	call for details	049532	Push-On Ring, 1520T
17	BP-4217-52	048260	Suction Screen
	call for details	051616	Suction Screen, 1520T
18	call for details	026031	Inlet Fitting, 1" FNPT used w/bung adapter
	BP-4217-63	048280	Inlet Fitting, 1" FNPT x 2" MNPT w/vent hole
	call for details	048491	Inlet Fitting, 1" FNPT x 2" MNPT w/o vent hole
19	BP-4217-65	048296	1/4-20 x 7/8 Lg. Hex Hd. Thread Forming Screw
20	call for details	048253	Fire Screen
	call for details	051613	Fire Screen, 1520T
21	call for details	048297	Push-On Ring
	call for details	049531	Push-On Ring, 1520T
22	call for details	026116	Bung Adapter Assembly
23	BP-4214-30	053245	1/4-20 x 3/4 Lg. Sq. Hd. Cup Pt. Set Screw

(Part List continues on following page) 35



### Gasboy Quick Reference

<p><b>BP-4210-02</b> Repair Kit - 20 Series (old style)</p> <p>For new style, order BP-4210-02N</p>	<p><b>BP-4210-01</b> Repair Kit for 1800, 70, 390</p>	<p><b>BP-4211-03</b> Repair Kit for 60 Series</p>
<p><b>BP-4210-29</b> Seal Kit (old style) - 20 series</p>	<p><b>BP-4210-29N</b> Seal Kit (new style) - 20 series</p>	<p><b>BP-4211-13</b> Seal Kit - 60 Series</p>
<p><b>BP-4210-20</b> Gasket (OEM #M05618B001 / 027055)</p>	<p><b>BP-4210-07-5</b> Vaness (5-pack) - Series 20-26</p>	<p><b>BP-4211-07</b> Vane - 60 Series</p>
<p><b>BP-4210-56</b> Rotor for 20 Series</p>	<p><b>BP-4211-04</b> Rotor - 60 Series</p>	<p><b>BP-4210-22</b> Rotor for 70 Series, 1800 &amp; 390</p>

**Gasboy Quick Reference**

**BP-4210-28**  
Check Valve Assy.



**BP-4210-30KP**  
Meter Register with Dial Glass

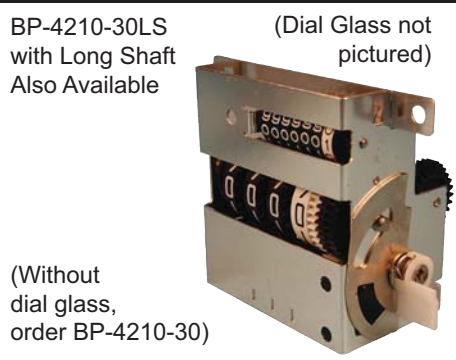

**BP-4211-36**  
Brush/Switch Replacement Kit



**BP-4210-23**  
Seal Kit for 70 Series & 1820



**BP-4217-05**  
Repair Kit for 1720A, 1520 & 787



**BP-4218-07A**  
Switch & Protector 4 Terminal



**BP-4210-60**  
Check Valve Retrofit Kits



**BP-4212-21**  
Left Wheel for 1860 Register



**BP-4212-20**  
Center Wheel for 1860 Register



**BP-4212-04**  
Meter Bezel - 4860



**BP-4212-40**  
Meter Bezel - Round (70 Series)



**BP-4210-80**  
Bypass Stem Assembly 70/1800





### Gasboy Quick Reference

**BP-4210-68**

Nozzle Hanger 1820



**BP-4212-34**

Round Dial Mask - Gallons



**BP-4212-73**

Toggle Switch for Motor 70 Series



**BP-4214-07**

Vane - Carbon



**BP-4212-02**

Repair Kit for 1860 Register



**BP-4217-10**

Repair Kit for 1700 Series



**BP-4218-30R**

Nozzle Boot - 70 Series (Red)



**BP-4210-58**

Vacuum Breaker Assembly



**BP-4211-23**

Vacuum Breaker Assembly



**BP-4218-20**

Motor for 70 Series

(Available in Red, White or Beige)

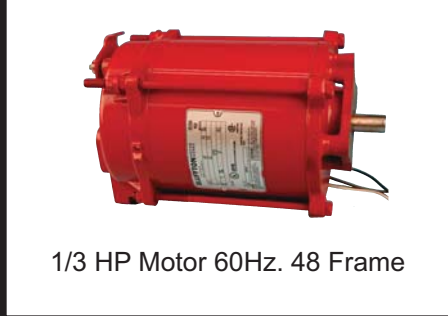

1/3 HP Motor 60Hz. 48 Frame

**BP-4218-28**

Motor for 1800 Series



1/3 HP Motor 60Hz. 48 Frame

**BP-4218-25 and BP-4218-26**

60 Hz. Motors for 20 Series



BP-4218-25 Motor for Models 25 & 250  
BP-4218-26 Motor for Models 26, 27, 28

## Gasboy Quick Reference

**BP-4210-67**  
Check Valve Assembly



**BP-4211-08**  
Check Valve - 60 Series



**BP-4210-04**  
Seal Kit - 600 Series



**BP-4212-17**  
Reset Bearing



**BP-4212-18**  
Reset Button



**BP-4212-03**  
Repair Kit for 4860 Register



**TERMS AND CONDITIONS OF THE  
SALES ORDER  
FOR SVI INTERNATIONAL, INC.**

1. **GENERAL.** The terms and conditions of sales order outlined herein shall apply to the sale by SVI INTERNATIONAL, INC. (hereinafter referred to as "Company") of the items described on the facing page (hereinafter referred to as "Merchandise") to Purchaser.
2. **DELIVERY.** Delivery shall be deemed to be complete when the Merchandise has been shipped F.O.B. Company's plants in DeKalb, Illinois, Duarte, California; and Baltimore, Maryland ("Company's plants"). Shipments are subject to delays from causes or contingencies beyond the reasonable control of the Company. When otherwise not specified, shipments will be made in standard containers via carrier which, in the judgment of the Company, will result in the most practical method. Title and right of possession will pass to the Purchaser upon receipt by the carrier at the shipping point. If a customer of the Company should specify a specific carrier's method of shipment (i.e. UPS Next Day Air) and that carrier does not perform to the customer's expectations, freight credit to a customer's account will not be issued unless the Company can first obtain a credit.
3. **RISK OF LOSS.** Identification of the Merchandise under Uniform Commercial Code (hereinafter referred to as "UCC") Section 2-501 shall take place at the moment of shipment F.O.B. Company's plants. Risk of loss shall pass to the Purchaser when the Merchandise is shipped from the Company's plants.
4. **TITLE.** Title to the merchandise shall transfer to the Purchaser when the Merchandise is shipped from the Company's plants.
5. **WARRANTIES.** The Company guarantees its products to be free from defects in workmanship and raw materials for a period of one year from date of purchase. THIS WARRANTY IS EXPRESSLY IN LIEU OF ANY AND ALL WARRANTIES EXPRESS OR IMPLIED. COMPANY DOES NOT WARRANT THE MERCHANDISE IS MERCHANTABLE OR FIT FOR ANY PARTICULAR PURPOSE. Company's liability for breach of the terms of this Agreement, including any warranty, is limited to either refund of the invoice price of the Merchandise or at Company's option, replacement of the Merchandise free of charge, including transportation charges but not including the cost of labor. Purchaser has not relied on any statement or upon the conduct of Company with respect to the prospective use of the merchandise. Company shall not be liable for and Purchaser waives any and all claims for any loss or damage, directly or indirectly, arising from the use of the Merchandise and for punitive, incidental or consequential damages, including, but not limited to, damages to property, for loss of use, loss of time, loss of profit or loss of income. The Company does not authorize the sale of our products under any other warranty, expressed or implied.
6. **SETOFF.** All claims for money due or to become due from the Company shall be subject to deduction by the Company for any setoff or counterclaim arising out of this or any other claims of the Company or its affiliated companies, whether such setoff or counterclaim arose before or after any assignment by Purchaser.
7. **INDEMNIFICATION.** Purchaser agrees to indemnify the Company and hold it harmless from and against all claims, liability, loss, damage or expense, including reasonable counsel fees, arising from or by reason of any modifications or alterations made by Purchaser. If a customer of the Company modifies or alters any part, in any manner whatsoever, or uses any part in departure from recommended performance specifications, said customer agrees to indemnify and hold the Company harmless from and against all liability and expenses based on damage to property or injury to or death of any person arising out of or attributable to such modified or altered part. Further, the Company will not accept any such modified or altered part for credit to a customer's account.
8. **FREIGHT POLICY.** Freight charges on individual orders less than \$3,000 in net value are prepaid and added to invoice or collect F.O.B. shipping point. Freight charges (standard ground service and continental US only) on individual orders more than \$3,000 net value are paid by the Company F.O.B. shipping point. Note: customers with C.O.D. terms are responsible for all carrier C.O.D. fees regardless of order net value.
9. **RETURN POLICY.** To return parts for credit or inspection Purchaser must first contact the Company to obtain a Return Goods Authorization number (RGA#). Once Purchaser has obtained an RGA# the parts can be returned freight prepaid only. The RGA# must be on the outside of the container in a highly visible location. All parts must be returned freight prepaid and the shipment must include a letter of explanation giving the specific reason for return including details as to the conditions under which the part or parts operated. Note: parts returned without an RGA#, freight collect or without written explanation may be refused. Parts which have been used in any way or manner, including any installation or incorporation into a lift or hoist, shall NOT be eligible for return whether or not an RGA has been assigned.
10. **RESTOCK CHARGE.** Returns are subject to up to twenty-five (25%) restocking charge. Refusals are subject to the same restocking charge plus the cost of outbound and return freight charges and/or fees incurred by the Company due to shipment refusal.
11. **PRICES AND PAYMENTS.** All prices are subject to change without notice. All prices are F.O.B. shipping point. The Company standard terms are net 30 days, C.O.D. company check, C.O.D. cash, VISA, MasterCard, Discover or American Express. However, if in the judgment of the Company, the financial condition of the Purchaser at any time does not justify shipment according to standard terms of payment, the Company may require full or partial payment in advance.
12. **INTERPRETATION.** This sales order is intended by the parties as a complete and exclusive statement of the terms of their agreement. It supersedes all prior agreements, written or oral. No course of prior dealings between the parties and no usage of the trade shall be relevant to supplement or explain any terms used in this sales order. Acceptance or acquiescence in a course of performance rendered under this purchase order shall not be relevant to determine the meaning of this sales order even though the accepting or acquiescing party has knowledge of the nature of the performance and opportunity for objection. Whenever a term defined by the UCC is used in this sales order the definition contained in the UCC shall control.
13. **MODIFICATION.** This sales order can be modified or rescinded only by a writing signed by both parties.
14. **WAIVER.** No claim or right arising out of a breach of this sales order can be discharged in whole or in part by a waiver or renunciation of the claim or right unless such waiver or renunciation is supported by consideration and is in writing signed by the aggrieved party.
15. **ASSIGNMENT.** No right or interest in this sales order shall be assigned by either party without the written consent of the other and no delegation of any obligation owed, or of the performance of any obligation by either the Company or Purchaser shall be made without the written consent of the other party. Any attempted assignment or delegation not made in conformity with this paragraph shall be wholly void and totally ineffective for all purposes.
16. **TIME TO PERFORM AND BRING ACTION.** Time is of the essence of this sales order. Any action for breach of this sales order shall be commenced within two (2) years after the cause of action has accrued. Any party who loses any litigation shall reimburse the other party for costs including reasonable attorneys fees. The exclusive jurisdiction for any legal action shall be the Circuit Court of DeKalb County, Illinois.
17. **APPLICABLE LAW.** This sales order shall be governed by the UCC of Illinois as effective and in force on the date of this sales order.

***Offering the Best in Automotive Lift Repair Parts and More!***

---

Auto Lift Cables • Auto Lift Parts • Brake Lathe Repair Parts

Compressed Air Repair Parts • Exhaust System Products • Fluid Delivery Repair Parts

Lubrication Equipment Repair Parts • Repair Parts for Gasboy Consumer Series

Service Station Pump and Tank Products • SVI Misc Auto Lift Products and Catalogs

Tire Changer Repair Parts • Vehicle Lifting Systems • Wheel Balancer Accessories

---

***Serving the Industry Since 1977 • Same-Day Shipping***



**SVI International, Inc.**

**(800) 321-8173 • fax: (800) 899-1784**

155 Harvestore Drive • DeKalb, IL 60115

**[www.sviinternational.com](http://www.sviinternational.com)**

**BALTIMORE • CHICAGO • LOS ANGELES**