

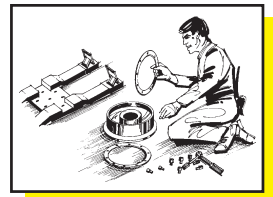

# The Twin Post



Single Page Update for the S V I Line of  
Automotive Service Equipment Repair Parts - July 1998 (1)

- Atlanta
- Baltimore
- Chicago
- Los Angeles

## NEW PACKING KITS FOR JOYCE/DAYTON LIFTS

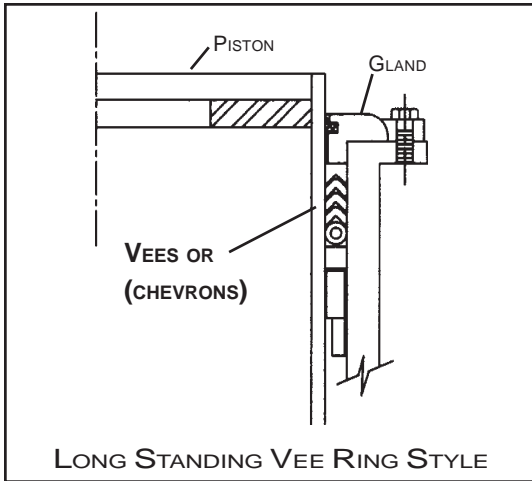

SVI has expanded the selection of lift Packing Kits for Joyce/Dayton Lifts, adding the new U-cup style used by the company.

This new U-cup style is a one piece, single lip seal design that installs quickly. The seals are pre-energized with ribs to help prevent low pressure leaking and field proven.

Each "Direct Fit" BRAND Packing Kit comes complete with the seal and wiper. Lift repair professionals have increased options with SVI products.

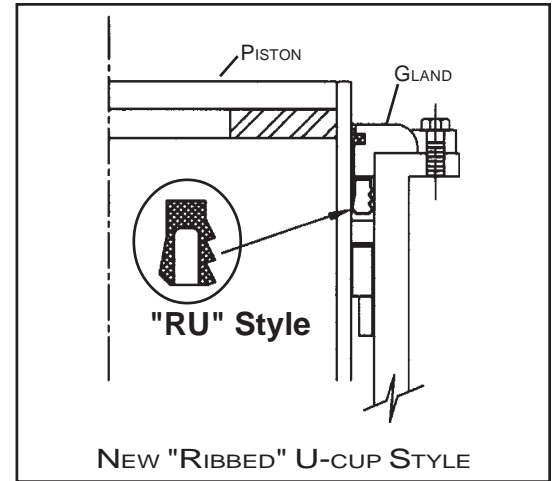

**SVI is the Answer!**

## ORDER YOUR PREFERENCE TODAY

### NEW RIBBED U-CUP STYLE

BH-1723RU	Joyce		7-1/2" Ribbed U-Cup Style Kit
BH-1793RU	Joyce		8-1/2" Ribbed U-Cup Style Kit
BH-1762RU	Joyce		10-1/2" Ribbed U-Cup Style Kit
BH-1712RU	Joyce		12-1/2" Ribbed U-Cup Style Kit
BH-1710RU	Joyce		13-3/4" Ribbed U-Cup Style Kit
BH-1714RU	Joyce	34117	15-3/4" Ribbed U-Cup Style Kit



### LONG STANDING VEE RING STYLE

BH-1723	Joyce	13791	7-1/2" Packing Kit
BH-1723SU	Joyce	13791	7-1/2" Leak Sealer Univ. Kit
BH-1793	Joyce	13851	8-1/2" Packing Kit
BH-1793SU	Joyce	13851	8-1/2" Leak Sealer Univ. Kit
BH-1762	Joyce	12354	10-1/2" Packing Kit
BH-1762SU	Joyce	12354	10-1/2" Leak Sealer Univ. Kit
BH-1712	Joyce	13219	12-1/2" Packing Kit
BH-1710	Joyce		13-3/4" Packing Kit
BH-1714V	Joyce	16806	15-3/4" Packing Kit Vee style

Entire Contents Copyright © SVI International, Inc. 1998

**To Order: 800-321-8173 or 630-365-9250 Fax: 800-899-1784 or 630-365-2809**

All names, numbers symbols and descriptions are used for reference purposes only. It is not implied that any part listed is the product of these manufacturers, however; some parts may be the actual product of these manufacturers.

# SVI - Lift Packing Kits

**QUALITY - Much More Than Meets the Eye!**

---

## Material

1. **Only the finest materials are used in order to provide you with the highest level of quality assurance.**
2. **Rubber Molded items are manufactured using a Carboxylated Nitrile compound rather than the normal run of the mill Nitriles used by others. This compound provides for greater abrasion resistance, most important in the lift environment.**
3. **ONLY 100% Virgin Materials are used - NO REGRINDS, NO FILLERS as found with lower quality producers.**

## The Molds

1. **Scheduled Mold Inspections are conducted routinely to assure proper alignment and product continuity.**
2. **As molds approach the end of their cycle life, they are replaced in order to produce product while maintaining the fit and finish expected.**

## Inspections

1. **Each seal is hand trimmed and inspected at four stages of production. (At prep for proper weight, after being demolded for non-fills and voids, during the trimming process and again in the QC Department.)**
2. **Inspection is done to a 4.0 AQL level using mil standard 105E, which is RMA (Rubber Mfg. Assoc.) Standard for Rubber Molded Goods.**
3. **At the time just prior to final kit assembly each component is once again 100% inspected.**

**LIFT PACKING KITS are SERIOUS BUSINESS at SVI**