

Automotive Lift

R E P A I R P A R T S



SVI International, Inc.
(800) 321-8173 • fax: (800) 899-1784
155 Harvestore Drive • DeKalb, IL 60115
www.sviinternational.com

BALTIMORE • CHICAGO • LOS ANGELES

Repair Parts for: **Forward**

Repair Parts for:
Forward

LRC7235



Insist on only SVI "Direct Fit" brand Lift Repair Parts.
entire contents copyright © 2010 SVI International, Inc.

for lift model DPO9A/DPO9A2

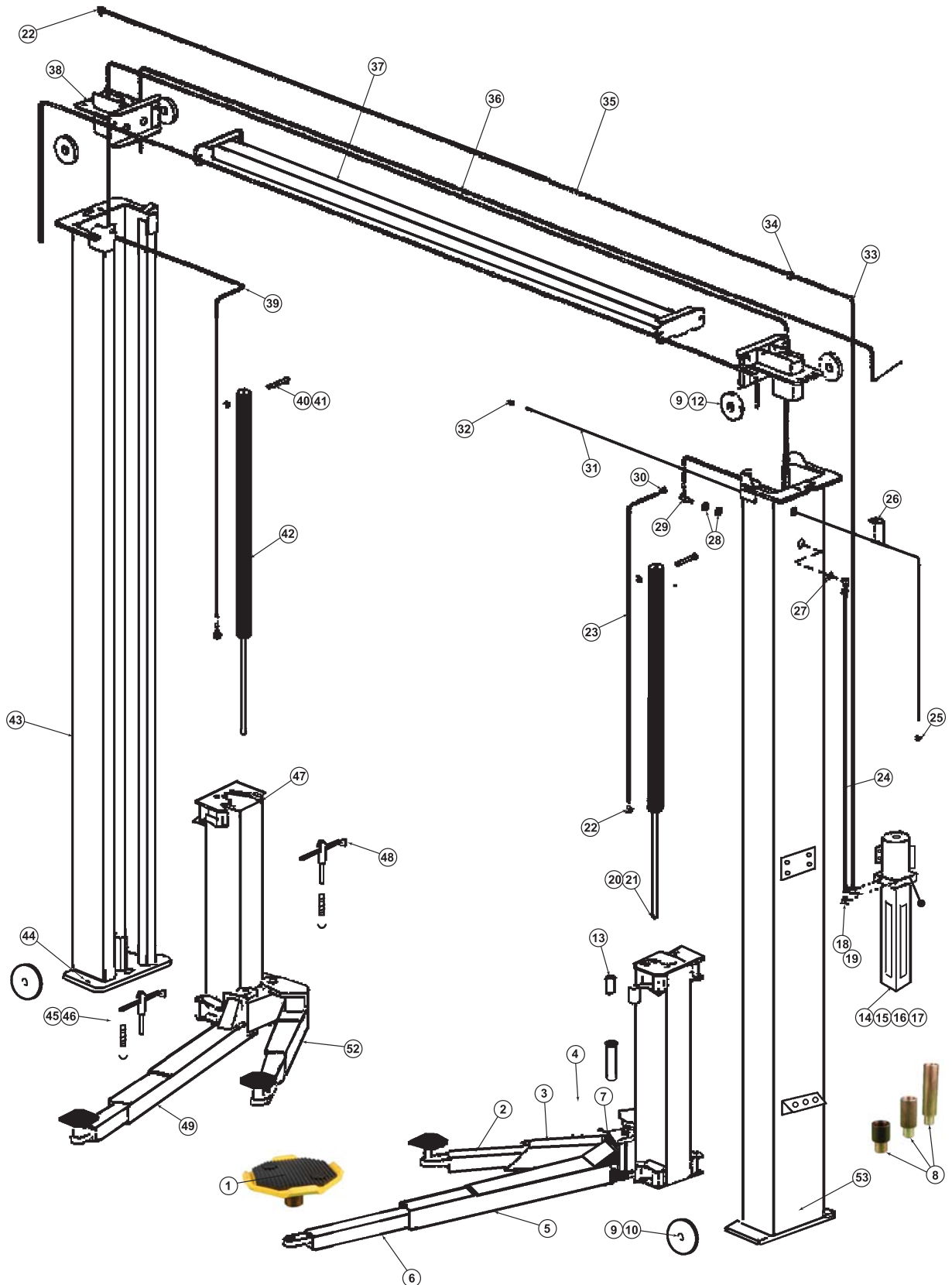

SVI "Direct Fit" brand Lift Repair Parts for Forward lifts.

entire contents copyright © 2010 SVI International, Inc.

Item	SVI part #	OEM #	Req	Description
1	BH-7089-97	106605	4	Adapter Base and Pad 1-1/4" Pin
2	BH-7239-17	106608	2	Short Inner Swing Arm
3	BH-7235-41	106606	1	Outer Front Swing ArmRH
4	BH-7235-34	995430	4	Swing Arm Pin 8"
5	BH-7239-225	106704	1	Outer Rear Swing Arm RH
6	BH-7239-21	106703	2	Inner Rear Swing Arm
7	BH-7235-91	991303	2	Bumper Strip 4-5/8" Long
8	BH-7235-70	995550		6" Pad Extension
	BH-7235-71	995560		3" Pad Extension
	BH-7235-72	996220		1-1/2" Pad Extension
9	BH-7237-85	991030		Top Rail Snap Ring
10	BH-7235-66	995030	2	Cable Sheave 5"
11	BH-7239-128	991211		Sheave Bushing
12	BH-7235-00	995020	4	Cable Sheave 4"
13	BH-7235-27	995120	16	Carriage Slider Block
14	BH-7006-01	992017	1	Power Unit AB-1135, RV19
15	F-HN-0312-18	911701	4	5/16" - 18 Hex Nut
16	F-NL-0312-18	911703	4	5/16-18 Nylock Nut
17	F-HC-0312-18-1000	911741	4	5/16-18 x 1" Hex Head Capscrew
18	F-A3105-6-6	992410		3/8" O-Ring to 3/8" Male JIC
19	BH-7235-67	992426		3/8" JIC 90 Swivel Nut
20	F-HN-0750-16	913602		3/4-16 Hex Nut
21	F-JN-0750-16	913611		3/4-16 Jam Nut
22	F-3405-6-6	992402		Elbow
23	BH-7236-42	992156	1	Hydraulic Hose 56"
24	BH-7236-39	992142	1	Hydraulic Hose 62" DPOA9
	BH-7237-55	992161		Hydraulic Hose 77" DPOA9A2
25	BH-7239-88	991244		1/8" Cable Clamp Threaded
26	BH-7239-89	106804		Overhead Limit Cable Ring
27	F-JN-0562-18	992454		3/8" Bulkhead Nut
28	F-FW-0562-SAE	912906		9/16" Flatwasher
29	F-3965-6	992431		3/8" JIC Bulkhead Run Tee
30	F-3355SW-6	995464		3/8" JIC 45 Swivel Nut
31	BH-7235-09C	992609		Limit Switch Cable 1/16" x 16'
32	BH-7239-90	991084		1/16 Cable Clamp
33	BH-7236-32	992137		3/8" Hose x 86" High Press
34	F-3605-6-6-6	992419		3/8" JIC Branch T to 3/8" MNPT
35	BH-7236-41	992144	1	Hydraulic Hose 114" DPOA9
	BH-7236-48	992159	1	Hydraulic Hose 176" DPOA9A2
36	BH-7235-08	992627	2	Equalizer Cable DPOA9
	BH-7235-09A	992639	2	Equalizer Cable DPOA9A2
37	BH-7239-100	106801	1	Overhead Weldment 113"
38	BH-7235-17	106802	2	Cylinder Mount Weldment
39	BH-7236-44	992157	1	Hydraulic Hose 209" DPOA9
	BH-7236-46	992158	1	Hydraulic Hose 257" DPOA9A2
40	F-NL-0500-13	912603		1/2-13 Nylock Nut
41	F-HC-0500-13-5000	912791		1/2-13 x 5" Hex Head Capscrew
42	BH-7236-02	992317	2	Hydraulic Cylinder
	BH-7235-15	991281		Hyd Cylinder Seal Kit (Prince)
	BH-7235-15A	992317SKAA		Hyd Cylinder Seal Kit (Arlington)
43	call for price	106201		Column
44	BH-7075-03	913828		3/4" x 5-1/2" Anchor Bolt
45	BH-7235-24I	106702	4	Arm Restraint Plunger 7"
46	BH-7235-24J	106701	2	Arm Restraint Slider Rear 11"
47	BH-7239-42	106501	1	Carriage Weldment
48	BH-7235-24A	070705	2	Arm Restraint Slider Bar Front 8"
49	BH-7239-226	106705	1	Outer Rear Swing Arm LH
50	F-HC-0500-13-0750	912631		1/2-13 x 3/4" Hex Head Capscrew
51	F-LW-0500	912607		1/2" Lock Washer
52	BH-7235-42	106607	1	Inner Front Swing Arm LH
53	call for price	106101	1	Power Unit Column

for lift model DPO9A/DPO9A2

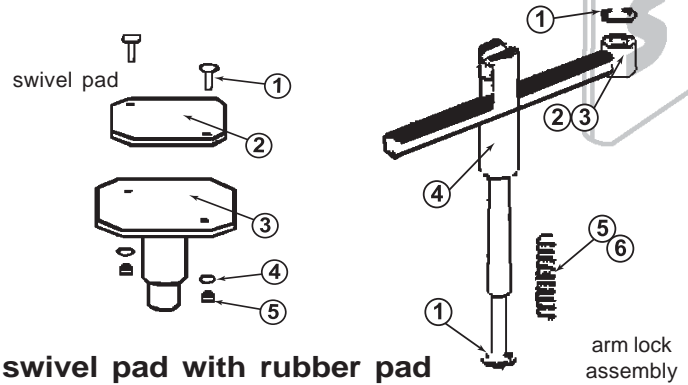

swivel pad with rubber pad

Item	SVI part #	OEM #	Req	Description
1	F-EB-0250-20-1000	991243	8	1/4" x 1" Elevator Bolt
2	BH-7235-90A	991234	4	Rubber Pad - standard duty
	BH-7235-90	994105	1	Rubber Pad Kit - standard duty
	BH-7235-90AX		4	Rubber Pad - heavy duty
	BH-7235-90K		1	Rubber Pad Kit - heavy duty
3	BH-7089-97	106605	4	Adapter Base and Pad 1-1/4" Pin
4	F-FW-0250-USS	911405	8	1/4" Flat Washer
5	F-HN-0250-20	911401	8	1/4"-20 Hex Nut

arm restraint parts

Item	SVI part #	OEM #	Req	Description
1	BH-7235-24E	991209	4	Arm Restraint E-Clip 5/8"
2	BH-7235-24A	070705	2	8" Slider
3	BH-7235-24J	106701	2	Arm Restraint Slider Rear 11"
4	BH-7235-24I	106702	4	Arm Restraint Plunger 7"
5	BH-7235-25	991216	4	Arm Restraint Spring
6	BH-7235-24D	913206	4	Arm Restraint Washer 5/8"

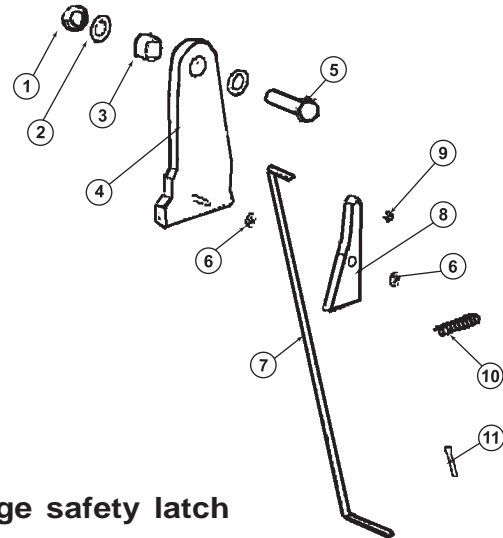

carriage safety latch

Item	SVI part #	OEM #	Req	Description
1	F-NL-0750-16	913600	2	3/4-16 Nylock Nut
2	F-FW-0750	913605	2	3/4" Flatwasher
3	BH-7239-95	070530	2	Latch Pivot
4	BH-7239-94	070525	2	Safety Latch
5	F-HC-0750-10-2000	913682	2	3/4-10 x 2 Hex Head Capscrew
6	F-FW-0375-USS	912005	2	3/8" Washer
7	BH-7237-19	090541	2	Lock Release Rod 17"
8	BH-7235-63	070528	2	Safety Latch Release Pawl
9	BH-7235-65	991070	2	Cap Nut
10	BH-7237-86	991071	2	Spring Latch
11	F-CP-094-1500	991077	2	Cotter Pin 3/32" x 1-1/2"

**TERMS AND CONDITIONS OF THE
SALES ORDER
FOR SVI INTERNATIONAL, INC.**

1. **GENERAL.** The terms and conditions of sales order outlined herein shall apply to the sale by SVI INTERNATIONAL, INC. (hereinafter referred to as "Company") of the items described on the facing page (hereinafter referred to as "Merchandise") to Purchaser.
2. **DELIVERY.** Delivery shall be deemed to be complete when the Merchandise has been shipped F.O.B. Company's plants in DeKalb, Illinois, Duarte, California; and Baltimore, Maryland ("Company's plants"). Shipments are subject to delays from causes or contingencies beyond the reasonable control of the Company. When otherwise not specified, shipments will be made in standard containers via carrier which, in the judgment of the Company, will result in the most practical method. Title and right of possession will pass to the Purchaser upon receipt by the carrier at the shipping point. If a customer of the Company should specify a specific carrier's method of shipment (i.e. UPS Next Day Air) and that carrier does not perform to the customer's expectations, freight credit to a customer's account will not be issued unless the Company can first obtain a credit.
3. **RISK OF LOSS.** Identification of the Merchandise under Uniform Commercial Code (hereinafter referred to as "UCC") Section 2-501 shall take place at the moment of shipment F.O.B. Company's plants. Risk of loss shall pass to the Purchaser when the Merchandise is shipped from the Company's plants.
4. **TITLE.** Title to the merchandise shall transfer to the Purchaser when the Merchandise is shipped from the Company's plants.
5. **WARRANTIES.** The Company guarantees its products to be free from defects in workmanship and raw materials for a period of one year from date of purchase. THIS WARRANTY IS EXPRESSLY IN LIEU OF ANY AND ALL WARRANTIES EXPRESS OR IMPLIED. COMPANY DOES NOT WARRANT THE MERCHANDISE IS MERCHANTABILITY OR FIT FOR ANY PARTICULAR PURPOSE. Company's liability for breach of the terms of this Agreement, including any warranty, is limited to either refund of the invoice price of the Merchandise or at Company's option, replacement of the Merchandise free of charge, including transportation charges but not including the cost of labor. Purchaser has not relied on any statement or upon the conduct of Company with respect to the prospective use of the merchandise. Company shall not be liable for and Purchaser waives any and all claims for any loss or damage, directly or indirectly, arising from the use of the Merchandise and for punitive, incidental or consequential damages, including, but not limited to, damages to property, for loss of use, loss of time, loss of profit or loss of income. The Company does not authorize the sale of our products under any other warranty, expressed or implied.
6. **SETOFF.** All claims for money due or to become due from the Company shall be subject to deduction by the Company for any setoff or counterclaim arising out of this or any other claims of the Company or its affiliated companies, whether such setoff or counterclaim arose before or after any assignment by Purchaser.
7. **INDEMNIFICATION.** Purchaser agrees to indemnify the Company and hold it harmless from and against all claims, liability, loss, damage or expense, including reasonable counsel fees, arising from or by reason of any modifications or alterations made by Purchaser. If a customer of the Company modifies or alters any part, in any manner whatsoever, or uses any part in departure from recommended performance specifications, said customer agrees to indemnify and hold the Company harmless from and against all liability and expenses based on damage to property or injury to or death of any person arising out of or attributable to such modified or altered part. Further, the Company will not accept any such modified or altered part for credit to a customer's account.
8. **FREIGHT POLICY.** Freight charges on individual orders less than \$3,000 in net value are prepaid and added to invoice or collect F.O.B. shipping point. Freight charges (standard ground service and continental US only) on individual orders more than \$3,000 net value are paid by the Company F.O.B. shipping point. Note: customers with C.O.D. terms are responsible for all carrier C.O.D. fees regardless of order net value.
9. **RETURN POLICY.** To return parts for credit or inspection Purchaser must first contact the Company to obtain a Return Goods Authorization number (RGA#). Once Purchaser has obtained an RGA# the parts can be returned freight prepaid only. The RGA# must be on the outside of the container in a highly visible location. All parts must be returned freight prepaid and the shipment must include a letter of explanation giving the specific reason for return including details as to the conditions under which the part or parts operated. Note: parts returned without an RGA#, freight collect or without written explanation may be refused. Parts which have been used in any way or manner, including any installation or incorporation into a lift or hoist, shall NOT be eligible for return whether or not an RGA has been assigned.
10. **RESTOCK CHARGE.** Returns are subject to up to twenty-five (25%) restocking charge. Refusals are subject to the same restocking charge plus the cost of outbound and return freight charges and/or fees incurred by the Company due to shipment refusal.
11. **PRICES AND PAYMENTS.** All prices are subject to change without notice. All prices are F.O.B. shipping point. The Company standard terms are net 30 days, C.O.D. company check, C.O.D. cash, VISA, MasterCard, Discover or American Express. However, if in the judgment of the Company, the financial condition of the Purchaser at any time does not justify shipment according to standard terms of payment, the Company may require full or partial payment in advance.
12. **INTERPRETATION.** This sales order is intended by the parties as a complete and exclusive statement of the terms of their agreement. It supersedes all prior agreements, written or oral. No course of prior dealings between the parties and no usage of the trade shall be relevant to supplement or explain any terms used in this sales order. Acceptance or acquiescence in a course of performance rendered under this purchase order shall not be relevant to determine the meaning of this sales order even though the accepting or acquiescing party has knowledge of the nature of the performance and opportunity for objection. Whenever a term defined by the UCC is used in this sales order the definition contained in the UCC shall control.
13. **MODIFICATION.** This sales order can be modified or rescinded only by a writing signed by both parties.
14. **WAIVER.** No claim or right arising out of a breach of this sales order can be discharged in whole or in part by a waiver or renunciation of the claim or right unless such waiver or renunciation is supported by consideration and is in writing signed by the aggrieved party.
15. **ASSIGNMENT.** No right or interest in this sales order shall be assigned by either party without the written consent of the other and no delegation of any obligation owed, or of the performance of any obligation by either the Company or Purchaser shall be made without the written consent of the other party. Any attempted assignment or delegation not made in conformity with this paragraph shall be wholly void and totally ineffective for all purposes.
16. **TIME TO PERFORM AND BRING ACTION.** Time is of the essence of this sales order. Any action for breach of this sales order shall be commenced within two (2) years after the cause of action has accrued. Any party who loses any litigation shall reimburse the other party for costs including reasonable attorneys fees. The exclusive jurisdiction for any legal action shall be the Circuit Court of DeKalb County, Illinois.
17. **APPLICABLE LAW.** This sales order shall be governed by the UCC of Illinois as effective and in force on the date of this sales order.

Offering the Best in Automotive Lift Repair Parts and More!

Auto Lift Cables • Auto Lift Parts • Brake Lathe Repair Parts

Compressed Air Repair Parts • Exhaust System Products • Fluid Delivery Repair Parts

Lubrication Equipment Repair Parts • Repair Parts for Gasboy Consumer Series

Service Station Pump and Tank Products • SVI Misc Auto Lift Products and Catalogs

Tire Changer Repair Parts • Vehicle Lifting Systems • Wheel Balancer Accessories

Serving the Industry Since 1977 • Same-Day Shipping



SVI International, Inc.

(800) 321-8173 • fax: (800) 899-1784

155 Harvestore Drive • DeKalb, IL 60115

www.sviinternational.com

BALTIMORE • CHICAGO • LOS ANGELES

While the utmost care has been used in compiling this reference material, we assume no responsibility for errors. Specifications are subject to change without notice. This edition supersedes all previous editions or issues. SVI reference material is subject to change without notice. All rights reserved.