



Wheel Balancer Accessories

Cones • Collets • Discs • Plates • Studs • Hub Plates • Adaptor Systems

SVI is your answer!

Cones • Collets • Discs • Plates • Studs • Hub Plates • Adaptor Systems

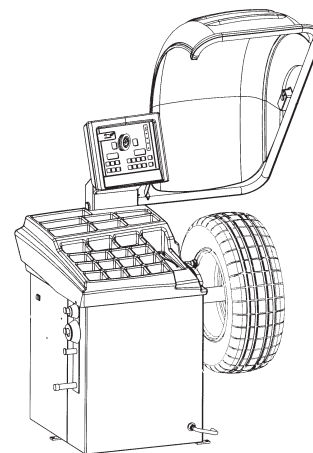
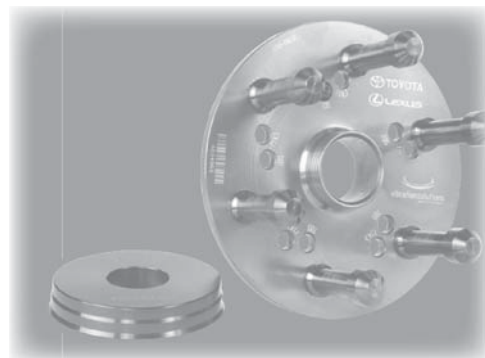

SVI International, Inc.

Baltimore • Chicago • Los Angeles

155 Harvestore Drive, DeKalb, IL 60115

Ph: 800-321-8173 • 815-748-0200 or Fax: 800-899-1784 • 815-748-0210



OEM Precision Collets™

**Great Solution for
Plastic Clad Wheels!**
Order as a kit(s),
or individually!

Car Dealership Kits
and Individual Collets
Also Available!

WB-L163-400-02

Tire Retail System (KIT) Solution B

Lite System includes 7 pieces double-sided Collets with a range covering virtually all cars and cross-over vehicles on the market. Wheel hub diameters between 54mm and 93mm. (Includes OEM Precision Collets™ #1-7)

WB-L163-400-03

Tire Retail System (KIT) Solution C

SUV/Truck System includes 4 pieces double-sided Collets with a range covering virtually all SUV and light truck vehicles on the market. Wheel hub diameters between 100mm and 125mm. (Includes OEM Precision Collets™ #9-12)

SOLUTION B



WB-L162-400-35

OEM Precision Collet™ #1

Side A: 54mm and 55mm
Side B: 56mm, 56.5mm and 57mm
Included in Solution B



WB-L162-400-34

OEM Precision Collet™ #2

Side A: 58mm and 58.5mm
Side B: 59mm, 59.5mm and 60mm
Included in Solution B



WB-L162-400-33

OEM Precision Collet™ #3

Side A: 63.3mm and 64mm
Side B: 65mm, 65.5mm, 66mm and 66.5mm
Included in Solution B



WB-L162-400-32

OEM Precision Collet™ #4

Side A: 67mm and 68mm
Side B: 69mm, 69.5mm, 70mm and 70.5mm
Included in Solution B



WB-L162-400-31

OEM Precision Collet™ #5

Side A: 71mm, 71.5mm, 72mm and 72.5mm
Side B: 73.8mm, 74mm and 74.5mm
Included in Solution B



WB-L162-400-30

OEM Precision Collet™ #6

Side A: 77.8mm and 78mm
Side B: 84mm and 85mm
Included in Solution B



WB-L162-400-29

OEM Precision Collet™ #7

Side A: 87mm
Side B: 92.5mm and 93mm
Included in Solution B

OEM Precision Collets™

SOLUTION C



WB-L162-400-27

OEM Precision Collet™ #9

Side A: 100mm
Side B: 105mm and 106mm
Included in Solution C

WB-L162-400-26

OEM Precision Collet™ #10

Side A: 107mm and 108mm
Side B: 109mm and 110mm
Included in Solution C

WB-L162-400-25

OEM Precision Collet™ #11

Side A: 113mm
Side B: 115.8mm (4.56") and 116.8mm
Included in Solution C
Used with a Small Spacer Disk on most balancers.

WB-L162-400-24

OEM Precision Collet™ #12

Side A: 121.6mm
Side B: 124mm and 125mm
Included in Solution C
Used with a Small Spacer Disk on most balancers.

**Great Solution for
Plastic Clad Wheels!**
Order as a kit(s),
or individually!

Car Dealership Kits
and Individual Collets
Also Available!

WB-L163-400-04

Mini System

These Collets are made just for the most difficult SUV and light truck wheels from Jeep, Dodge and GM, etc. These wheels have a plastic chrome looking disk covering the wheel. Also for Toyota, Lexus, Nissan and other Japanese SUV and light truck wheels.

MINI SYSTEM



WB-L162-400-20

OEM Precision Collet™

Side A: 106mm (Lexus, Toyota)
Side B: 110mm (Lexus, Toyota)
Included in Mini System

WB-L162-400-21

OEM Precision Collet™

Side A: 100mm (Acura, GM, Honda, Isuzu, Nissan)
Side B: 110mm (GM, Infiniti, Lexus, Mazda, Misubishi, Nissan, Suzuki, Toyota)
Included in Mini System

WB-L162-400-22

OEM Precision Collet™

Side A: 66.5mm and 67mm (Chrysler, Dodge, GM, and others)
Side B: 71.5mm (Chrysler, Dodge, Eagle, Jeep, and others)
Included in Mini System

WB-L162-400-23

OEM Precision Collet™

Side A: 74mm and 74.5 (GM and others)
Side B: 77.8mm and 78mm (Chrysler, Dodge, GM, and others)
Included in Mini System



CenTor™ System for Cars

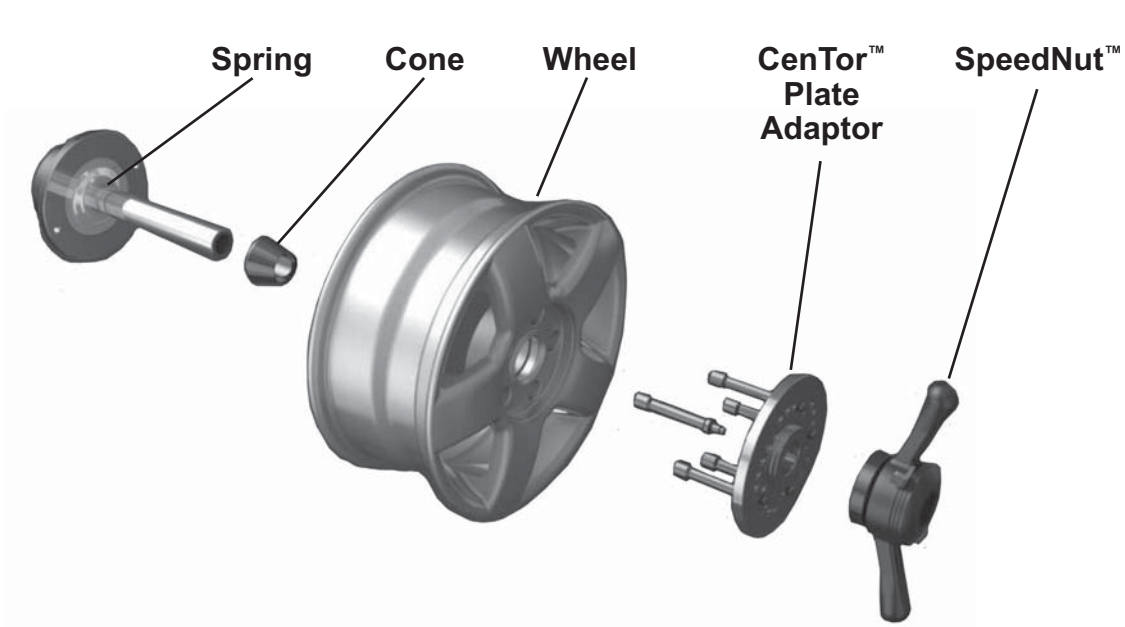

CenTor™ System for Light Trucks

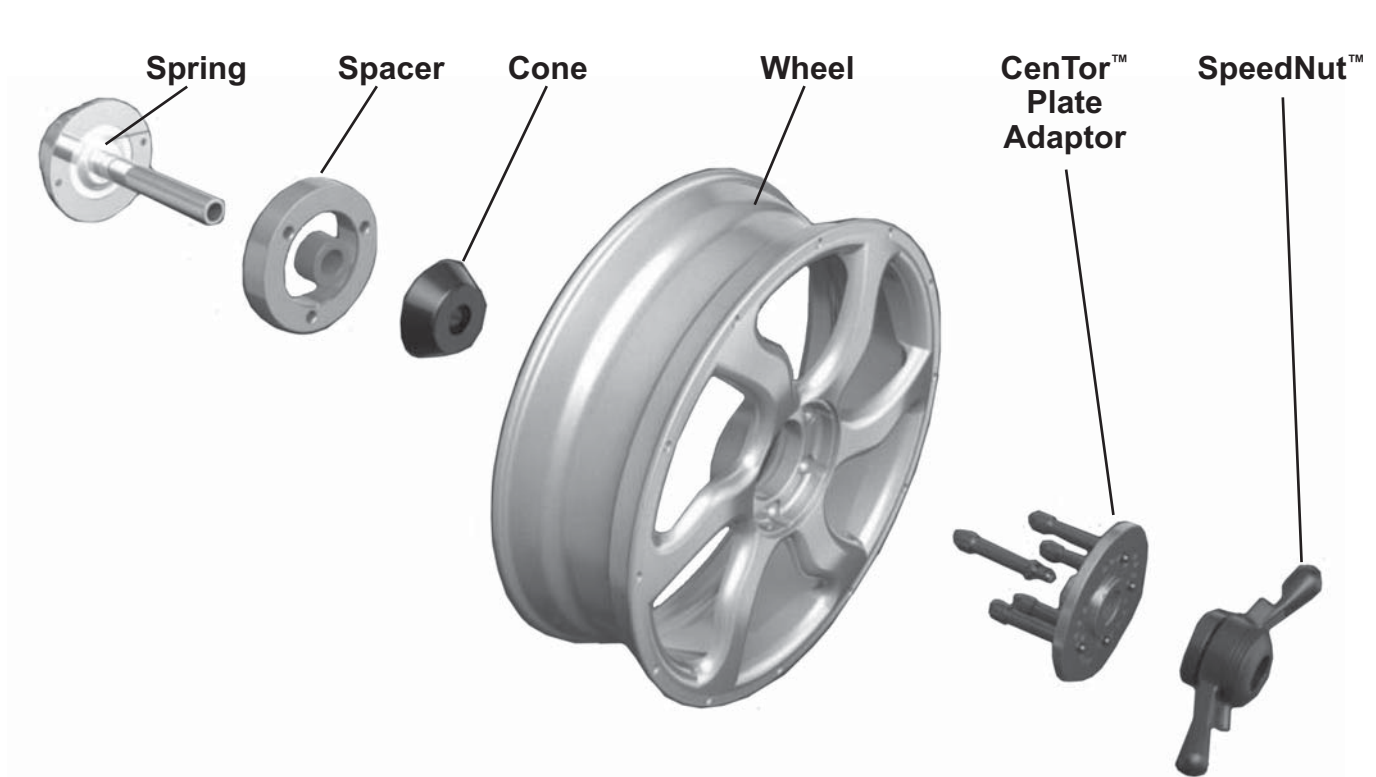

Cones and Cone Kits



WB-L150-400-14
WB-L150-380-14
WB-L150-360-14
WB-L150-280-14

Large Truck Cone *Heavy Duty Version*

Range: 4.725"–6.85" (120mm–174mm)

Through hardened for durability. Modern single-sided design optimizes handling and grip compared to old double-sided design. Same taper/angle as other double-sided truck cones.

WB-V150-400-14

Large Truck Cone *Super Duty Version*

Range: 4.725"–6.85" (120mm–174mm)

Through hardened for durability. Then, surface hardened for additional durability and rust proofing. Modern single-sided design optimizes handling and grip compared to old double-sided design. Same taper/angle as other double-sided truck cones.

WB-L150-400-35

Medium Step Cone *Hub Centric Wheels*

Range: 5.059"–5.638" (128mm–143mm)

Surface hardened for durability and rust proofing. Lower taper/angle for optimum balancing results on hub centric wheels, such as Ford F350 (8x200mm), GM (10x7.25"), Isuzu, Iveco, Opel, Renault, and more.

WB-L150-400-36

Large Step Cone *Hub Centric Wheels*

Range: 6.190"–6.972" (157mm–177mm)

Surface hardened for durability and rust proofing. Low taper/angle for optimum balancing results on hub centric wheels, such as Ford F450/F550, GM (10x8.75"), Hino, Mitsubishi, Sprinter (6x205mm) and many more.

WB-L154-400-01

Large Truck Cone KIT *Heavy Duty Version*

WB-L154-380-01

Includes: Large Truck Cone (WB-L150-xx0-14) and Large Spacer Disk (WB-L190-xx0-01).

WB-L154-360-01

Specify shaft size (in mm): 40, 38, 36, 28

WB-L154-280-01

WB-V154-400-01

Large Truck Cone KIT *Super Duty Version*

Includes: Large Truck Cone (WB-V150-400-14) and Large Spacer Disk (WB-V190-400-01).



Cone Kits and Accessories



WB-V154-400-02

Large Truck Cone KIT *Total Truck*

Includes: Large Truck Cone (WB-V150-400-14, Medium Step Cone (WB-L150-400-35), Large Step Cone (WB-L150-400-36) and Large Spacer Disk (WB-V190-400-01). Use Large Truck Cone for older wheels and Step Cones for newer hub centric wheels.



WB-V154-400-03

Step Cone KIT *Hub Centric Truck*

Includes: Medium Step Cone (WB-L150-400-35), Large Step Cone (WB-L150-400-36), and Large Spacer Disk (WB-V190-400-01)



WB-L190-400-01
WB-L190-380-01
WB-L190-360-01
WB-L190-280-01

Large Spacer Disk *Heavy Duty Version*

Outside Diameter: 8.74" (222mm). Through hardened for durability. Precision ground for superior balancing results. Far more accurate and longer lasting than spacer disks made from aluminum, plastic or carbon steel.



WB-V190-400-01

Large Spacer Disk *Super Duty Version*

Outside Diameter: 8.74" (222mm). Through hardened for durability. Then, surface hardened for additional dent resistance and rust proofing. Precision ground for superior balancing results. Far more accurate and longer lasting than spacer disks made from aluminum, plastic or carbon steel.

Wheel Balancer Accessories

SpeedNut™ shown in composite.
Also available in chrome.



SpeedNut™ • Cones • Collets Center Adaptor System

The options are endless.

***Call today to get pricing on
precise wheel balancer products!***

CenTor™ Adaptor System

by Vibration Solutions



Your Choice:
Heavy Duty or Super Duty
Call with balancer model to order.



PERFECT CENTERING

Perfect Centering – Perfect Torque.

The CenTor™ adaptor system will center and torque the wheel onto the balancer just like it is mounted onto the vehicle.

Perfect balancing results in a smooth vibration free ride and a happy customer. Since the CenTor™ Studs touch only where the lug nuts touch you will never again damage an expensive alloy wheel. Having the right tool for the right job saves you time and money.



**CenTor™
Adaptor System**



CAR DEALERS

Many vehicle manufacturers have already made the CenTor™ adaptor system a mandatory or essential tool to their dealer network. They know that only the CenTor™ adaptor system will avoid, or solve, customer ride complaints with this level of ease and speed and without the risk of damage to the customer's wheels. Different adaptor kits are available for specific brands as well as mixed dealerships. These Dealership kits come complete with directions, CenTor™ Plates, CenTor™ Studs and, when needed, specific Cones or Collets.

- | | | |
|------------|-----------------|--------------|
| • Audi | • Honda | • Nissan |
| • BMW | • Infiniti | • Toyota |
| • Cadillac | • Land Rover | • Volkswagen |
| • Chrysler | • Lexus | • And More! |
| • Ford | • Mercedes-Benz | |

TIRE DEALERS

Hub centric and lug centric wheels! Ball seat and tapered lug nut design! Tire dealers need one single guaranteed method to use on all wheels. The **CenTor™ Adaptor System**, for tire dealers, covers about 97% of all bolt patterns and wheel designs up to one ton trucks. The laminated application chart list vehicle brands and models along with bolt pattern, CenTor™ plate number and CenTor™ stud number to use. It's fast, easy and foolproof. Do the job correctly—the first time!



CenTor™ Adaptor System (Individual Plates—Standard in Full System)

See the following pages for CenTor™ Kits



Heavy Duty:
WB-L201-400-01
WB-L201-380-01
WB-L201-360-01
WB-L201-280-01

Super Duty:
WB-V201-400-01

CenTor Plate #1

Available in Heavy Duty OR Super Duty Versions
Standard Part in Full System

Bolt Patterns: 4x100mm, 4x4.25 (108mm), 4x110mm, 4x4.5" (114.3mm), 8x6.5" (165.1mm), and 8x170mm
CenTor Studs sold separately.



Heavy Duty:
WB-L205-400-01
WB-L205-380-01
WB-L205-360-01
WB-L205-280-01

Super Duty:
WB-V205-400-01

CenTor Plate #2

Available in Heavy Duty OR Super Duty Versions
Standard Part in Full System

Bolt Patterns: 5x100mm, 5x110mm, 5x4.5" (114.3mm), 5x120mm, 5x5" (127mm), 5x135mm, and 8x170mm
CenTor Studs sold separately.



Heavy Duty:
WB-L205-400-02
WB-L205-380-02
WB-L205-360-02
WB-L205-280-02

Super Duty:
WB-V205-400-02

CenTor Plate #3

Available in Heavy Duty OR Super Duty Versions
Standard Part in Full System

Bolt Patterns: 5x4.25" (108mm), 5x112mm, 5x115mm, 5x4.75" (120.65mm), 5x130mm, 5x5" (139.7mm), and 5x6.5" (165.1mm)
CenTor Studs sold separately.



Heavy Duty:
WB-L206-400-04
WB-L206-380-04
WB-L206-360-04
WB-L206-280-04

Super Duty:
WB-V206-400-04

CenTor Plate #4

Available in Heavy Duty OR Super Duty Versions
Standard Part in Full System

Bolt Patterns: 6x4.5" (114.3mm), 6x115mm, 6x5" (127mm), 6x132mm, 6x135mm, and 6x5.5" (139.7)
CenTor Studs sold separately.



See the following pages for CenTor™ Plate System Kits

CenTor™ Adaptor System Kits



WITH Storage Solution #1 (Floor Stand)

- WB-L200-400-01
- WB-L200-380-01
- WB-L200-360-01
- WB-L200-280-01



WITH Storage Solution #4 (Wall Board)

- WB-L200-400-25
- WB-L200-380-25
- WB-L200-360-25
- WB-L200-280-25



WITHOUT Storage Solution

- WB-L200-400-09
- WB-L200-380-09
- WB-L200-360-09
- WB-L200-280-09



CenTor Plate System Heavy Duty Version
With Storage Solution #1 OR #4 (or Without Storage)

This 4-plate system covers over 99% of all passenger cars, cross-overs, SUVs, and light trucks in the North American market. Trough hardened for durability and strength. Bolt patterns are deep engraved by each hold for ease of use.

Use 8 studs on 8 lug wheels and 6 studs on all six lug wheels for greatly improved accuracy. The CenTor Plate System is the most accurate balancing concept available. Got a vibration problem? An unhappy customer? The CenTor Plate System is the go-to solution! This version by Vibration Solutions is guaranteed to be the most accurate and easiest to use on the market.

SYSTEM INCLUDES:

- Plate #1** (4 & 8 Lug – WB-L201-xx0-01)
- Plate #2** (5 Lug – WB-L205-xx0-01)
- Plate #3** (5 Lug – WB-L205-xx0-02)
- Plate #4** (6 Lug – WB-L206-400-04)
- 8 pcs. A-style Studs** (WB-L275-100-13)
- 8 pcs. B-style Studs** (WB-L275-075-11)
- 5 pcs. C-style Studs** (WB-L275-105-14)
- Application Chart & User Manual** (WB-M299-001-01)

Choose your favorite storage system (or available without):

Storage Solution #1 - Floor Stand (WB-M280-000-03)

Storage Solution #4 - Wall Board (WB-M280-000-20)
(Hangs on Wall or Storage Solution #6)



Storage #1
(Floor Stand)



Storage #4
(Wall Board)



CenTor™ Adaptor System Kits



WITH Storage Solution #1 (Floor Stand)
WB-V200-400-01



WITH Storage Solution #4 (Wall Board)
WB-V200-400-25

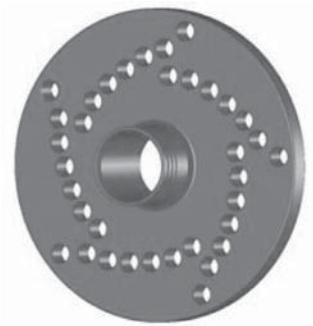

For WITHOUT Storage Solution, Order:
WB-V200-400-09

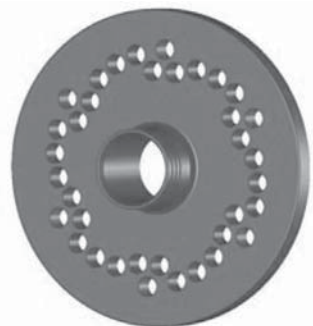

CenTor Plate System *Super Duty Version* *With Storage Solution #1 OR #4 (or Without Storage)*

This 4-plate system covers over 99% of all passenger cars, crossovers, SUVs, and light trucks in the North American market.

Trough hardened for durability and strength. Then, surface-hardened for scratch resistance and rust-proofing. Bolt patterns are deep engraved by each hold for ease of use. The plates are color-coded blue, red, yellow and green.

Use 8 studs on 8 lug wheels and 6 studs on all 6 lug wheels for greatly improved accuracy. The CenTor Plate System is the most accurate balancing concept available. Got a vibration problem? An unhappy customer? The CenTor Plate System is the go-to solution! This version by Vibration Solutions is guaranteed to be the most accurate and easiest to use on the market.

SYSTEM INCLUDES:

- Plate #1** (4 & 8 Lug – WB-V201-xx0-01)
- Plate #2** (5 Lug – WB-V205-xx0-01)
- Plate #3** (5 Lug – WB-V205-xx0-02)
- Plate #4** (6 Lug – WB-V206-400-04)
- 8 pcs. A-style Studs** (WB-L275-100-13)
- 8 pcs. B-style Studs** (WB-L275-075-11)
- 5 pcs. C-style Studs** (WB-L275-105-14)
- Application Chart & User Manual** (WB-M299-001-01)

Choose your favorite storage system (or available without):

Storage Solution #1: Floor Stand (WB-M280-000-03)

Storage Solution #4: Wall Board (WB-M280-000-20)
(Hangs on Wall or Storage Solution #6)

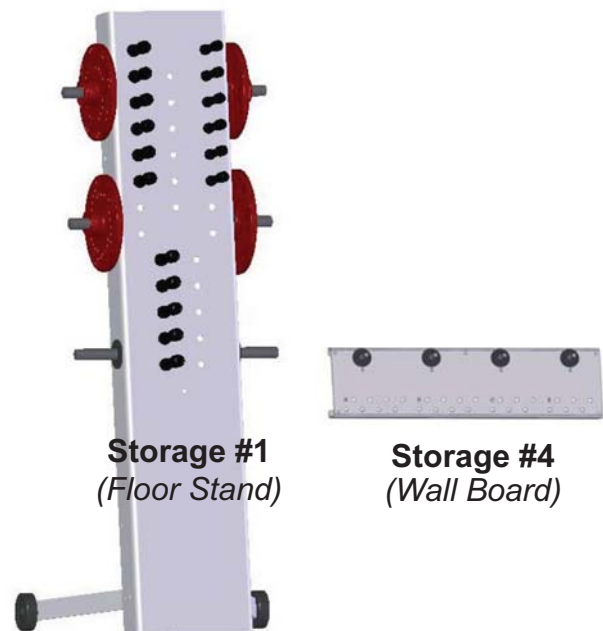

CenTor™ Adaptor System (Individual Plates—Optional)



WB-L201-400-02
WB-L201-280-02
WB-L201-818-02
(Specify Balancer Model when Ordering)

CenTor™ Plate #1 - SUV / Light Truck

6-Lug SUV / Lt. Truck Wheels + 8 Lug SUV / Lt. Truck Wheels
Bolt Patterns: 6x4.5" (114.3), 6x115mm, 6x5" (127mm), 6x132mm, 6x5.5" (139.7mm), 8x6.5" (165.1mm), 8x170mm
CenTor Studs sold separately.



WB-L205-400-10
WB-L205-280-10
WB-L205-818-10
(Specify Balancer Model when Ordering)

CenTor™ Plate #2 - SUV / Light Truck

5-Lug SUV / Lt. Truck Wheels
Bolt Patterns: 5x4.75" (120.65mm), 5x5" (127mm), 5x135mm, 5x5.5 (139.7mm), 5x150mm, 5x6.5" (165.1mm)
CenTor Studs sold separately.

CenTor™ Adaptor System Kit For SUV / 4x4



Specify Balancer Model when Ordering

WITH Storage Solution #4 (Wall Board)

WB-L200-400-27
WB-L200-380-27
WB-L200-360-27
WB-L200-280-27
WB-L200-818-27

WITHOUT Storage Solution

WB-L200-400-15
WB-L200-380-15
WB-L200-360-15
WB-L200-280-15
WB-L200-818-15

CenTor™ Adaptor System - SUV / Light Truck

Includes:

CenTor Plates L201-xx0-02 Plate #1 - SUV/Lt. Truck
L205-xx0-10 Plate #2 - SUV/Lt. Truck
CenTor Studs (Long) L275-075-11 B-Style (6 pieces)
L275-100-13 A-Style (6 pieces)
Application Chart M299-001-07

OPTIONAL:

Storage Solution #4 M280-000-20





CenTor™ Adaptor System—Studs

STANDARD CENTOR STUDS (included in full system)



WB-L275-100-13

CenTor Stud - Style A

Standard Part in All Systems

Cone seat. Head diameter 20.9mm. Base diameter 20.9mm.

Body length 100mm. Total length 117.8mm.

Used on passenger, SUV, and many light truck wheels.



WB-L275-075-11

CenTor Stud - Style B

Standard Part in All Systems

Short cone seat. Head diameter 24.5mm.

Base diameter 24.5mm. **Body length 75mm.**

Total length 92.8mm.

Used mainly on steel light truck wheels.



WB-L275-105-14

CenTor Stud - Style C

Standard Part in All Systems

Ball seat. Head diameter 24.5mm. Base diameter 24.5mm.

Body length 105mm. Total length 122.8mm.

Used on older balancers with very short shafts.

OPTIONAL CENTOR STUDS



WB-L275-085-13

CenTor Stud - Style A

Optional Part

Cone seat. Head diameter 20.9mm. Base diameter 20.9mm.

Body length 85mm. Total length 102.8mm.

Used on older balancers with very short shafts.



WB-L275-085-14

CenTor Stud - Style C

Optional Part

Ball seat. Head diameter 24.5mm. Base diameter 24.5mm.

Body length 85mm. Total length 102.8mm.

Used on older balancers with very short shafts.



WB-L275-075-12

CenTor Stud - Style D

Optional Part

Range Rover seat. Head diameter 34mm. Base diameter 34mm.

Body length 75mm. Total length 92.8mm.

Used only on Range Rover model before 1994.



WB-L275-095-15

CenTor Stud - Style E

Optional Part

Cone seat. Head diameter 19mm. Base diameter 20.9mm.

Body length 95mm. Total length 112.8mm.

Used mainly on tuner wheels.

CenTor™ Adaptor System—O-Rings



WB-S275-001-02 **O-Ring** (*bag of 25 pieces*)
Fits CenTor Studs with serial numbers **lower than A050000**.

WB-S275-001-03 **O-Ring** (*bag of 25 pieces*)
Fits CenTor Studs with serial numbers **higher than A050001**.

Application Chart

Included in Kits and also available to order separately.
User directions and list of all vehicles with
correct plate and stud to use. Color-coded and Laminated.

WB-M299-001-01 For WB-L200-xx0-01, WB-L200-xx0-03, WB-L200-xx0-05,
WB-L200-xx0-07, WB-L200-xx0-09, and WB-L200-xx0-25

WB-M299-001-07 For WB-L200-xx0-15 and WB-L200-xx0-27

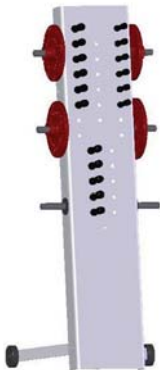

WB-M280-000-03 **Storage Solution #1 Floor Stand**
Easy reach to all adaptors due to stand's 48" height.
Holds all standard and optional CenTor Studs in the small holes.
Hold the four CenTor Plates on the upper two rods and holds
any other optional adaptors on the lowest rod.



WB-M280-000-20 **Storage Solution #4 Wall Board for CenTor System**
Hangs on wall or Storage Solution #6. Holds CenTor Adaptors
and CenTor Studs.



Wheels not shown.

WB-M280-000-22 **Storage Solution #6 Floor Stand Holds Wall Boards**
This stand holds up to 6 different wall boards such as the
Storage Solution #4 (above). The stand moves easily around
any shop on four included caster wheels (not shown).
Assembles easily.



CenTor™ Adaptor System—For Car Dealerships

General Motors (GM)

See individual parts on the following page.

WB-L526-400-01 **Balancing Adaptor System *Solution A***

WB-L526-380-01

WB-L526-360-01

WB-L526-280-01

SYSTEM INCLUDES:

OEM Precision Collet #1 (WB-L162-xxx-35)

OEM Precision Collet #2 (WB-L162-xxx-36)

OEM Precision Collet #3 (WB-L162-xxx-37)

OEM Precision Collet #4 (WB-L162-xxx-23)

OEM Precision Collet #5 (WB-L162-xxx-10)

CenTor Plate #1 (WB-L204-xxx-10)

CenTor Plate #2 (WB-L205-xxx-16)

CenTor Plate #3 (WB-L206-xxx-10)

CenTor Stud "A" (WB-L275-100-13) - 8 pieces

CenTor Stud "B" (WB-L275-075-11) - 8 pieces

Application Chart (WB-M299-001-10)

WB-L526-400-02 **Balancing Adaptor System *Solution B***

WB-L526-380-02

WB-L526-360-02

WB-L526-280-02

SYSTEM INCLUDES:

CenTor Plate #1 (WB-L204-xxx-10)

CenTor Plate #2 (WB-L205-xxx-16)

CenTor Plate #3 (WB-L206-xxx-10)

CenTor Stud "A" (WB-L275-100-13) - 8 pieces

CenTor Stud "B" (WB-L275-075-11) - 8 pieces

Application Chart (WB-M299-001-10)

Looking for a different Dealership Adaptor System?

- Acura • Audi • BMW • Chrysler • Dodge • Ford • GM • Honda • Infiniti • Jaguar
- Jeep • Land Rover • Lexus • Lincoln • Mercedes-Benz • Mercury
- Mini • Nissan • Scion • Smart • Subaru • Toyota • VW • More!

Just give us a call: 800-321-8173 • SVI has it available!

Centor™ Adaptor System—For Car Dealerships

General Motors (GM) - Individual Parts for Systems



WB-L162-400-35
WB-L162-380-35
WB-L162-360-35
WB-L162-280-35

OEM Precision Collet™ #1

Side A: 54mm
Side B: 56mm, 56.5mm, 57mm
Included in GM Solution A



WB-L162-400-36
WB-L162-380-36
WB-L162-360-36
WB-L162-280-36

OEM Precision Collet™ (GM) #2

Side A: 65mm
Side B: 67mm
Included in GM Solution A



WB-L162-400-37
WB-L162-380-37
WB-L162-360-37
WB-L162-280-37

OEM Precision Collet™ (GM) #3

Side A: 69mm, 70mm, 70.2mm
Side B: 70mm, 70.2mm, 71mm
Included in GM Solution A



WB-L162-400-23
WB-L162-380-23
WB-L162-360-23
WB-L162-280-23

OEM Precision Collet™ (GM) #4

Side A: 74.5mm
Side B: 78mm
Included in GM Solution A



WB-L162-400-38
WB-L162-380-38
WB-L162-360-38
WB-L162-280-38

OEM Precision Collet™ (GM) #5

Side A: 100mm
Side B: 4.56" (115.8mm) & 4.6" (116.8mm)
Included in GM Solution A



WB-L202-400-10
WB-L202-380-10
WB-L202-360-10
WB-L202-280-10

Centor Plate™ Heavy Duty Version

Bolt Patterns: 4x100mm, 4x4.5" (114.3mm) & 8x6.5" (165.1mm)
Included in GM Solution A and GM Solution B
Centor Studs Sold Separately.



WB-L205-400-16
WB-L205-380-16
WB-L205-360-16
WB-L205-280-16

Centor Plate™ Heavy Duty Version

Bolt Patterns: 5x100mm, 5x110mm, 5x115mm, 5x120mm,
5x4.75" (120.65mm), 5x5" (127mm), 5x5.5" (139.7mm)
Included in GM Solutions A and B
Centor Studs Sold Separately.



WB-L206-400-10
WB-L206-380-10
WB-L206-360-10
WB-L206-280-10

Centor Plate™ Heavy Duty Version

Bolt Patterns: 6x115mm, 6x120mm, 6x5" (127mm), 6x132mm &
6x5.5 (139.7mm)
Included in GM Solutions A and B
Centor Studs Sold Separately.



WB-L275-075-13

Centor Stud™ Style B

Short cone seat. Head diameter: 24.5mm; Base diameter:
24.5mm; Body length: 75mm; Total length: 92.8mm
Included in GM Solutions A and B



WB-L275-100-13

Centor Stud™ Style A

Cone seat. Head diameter: 20.9mm; Base diameter: 20.9mm;
Body length: 100mm; Total length: 117.8mm
Included in GM Solutions A and B



CenTor™ Adaptor System—For Car Dealerships Rotunda: Ford, Lincoln, Mercury

See individual parts on the following page.

WB-L508-400-07 **Balancing Adaptor System Solution A**

WB-L508-380-07

WB-L508-360-07

WB-L508-280-07

SYSTEM INCLUDES:

OEM Precision Collet (WB-L162-xxx-33)

OEM Precision Collet (WB-L162-xxx-32)

OEM Precision Collet (WB-L164-xxx-03)

OEM Precision Collet (WB-L162-xxx-24)

CenTor Plate (WB-L202-xxx-06)

CenTor Plate (WB-L202-xxx-07)

CenTor Stud “A” (WB-L275-100-13) - 8 pieces

CenTor Stud “B” (WB-L275-075-11) - 8 pieces

Truck Step Cone (WB-V760-xxx-01)

Universal Spacer Disk (WB-V790-xxx-05)

Application Chart (WB-M299-001-08)

WB-L508-400-06

WB-L508-380-06

WB-L508-360-06

WB-L508-280-06

Balancing Adaptor System Solution B

SYSTEM INCLUDES:

OEM Precision Collet (WB-L162-xxx-33)

OEM Precision Collet (WB-L162-xxx-32)

OEM Precision Collet (WB-L164-xxx-03)

OEM Precision Collet (WB-L162-xxx-24)

CenTor Plate (WB-L202-xxx-06)

CenTor Plate (WB-L202-xxx-07)

CenTor Stud “A” (WB-L275-100-13) - 8 pieces

CenTor Stud “B” (WB-L275-075-11) - 8 pieces

Application Chart (WB-M299-001-08)

WB-L508-400-04

WB-L508-380-04

WB-L508-360-04

WB-L508-280-04

Balancing Adaptor System Solution C

SYSTEM INCLUDES:

CenTor Plate (WB-L202-xxx-06)

CenTor Plate (WB-L202-xxx-07)

CenTor Stud “A” (WB-L275-100-13) - 8 pieces

CenTor Stud “B” (WB-L275-075-11) - 8 pieces

Application Chart (WB-M299-001-08)

Centor™ Adaptor System—For Car Dealerships

Rotunda: Ford, Lincoln, Mercury - Individual Parts for Systems



WB-L162-400-33
WB-L162-380-33
WB-L162-360-33
WB-L162-280-33

OEM Precision Collet™ #3
Side A: 63.3mm
Side B: 66mm
Included in Ford, Lincoln, Mercury Solutions A & B



WB-L162-400-32
WB-L162-380-32
WB-L162-360-32
WB-L162-280-32

OEM Precision Collet™ #4
Side A: 67mm
Side B: 70.5mm
Included in Ford, Lincoln, Mercury Solutions A & B



WB-L162-400-24
WB-L162-380-24
WB-L162-360-24
WB-L162-280-24

OEM Precision Collet™ #12
Side A: 121.6mm (4.77")
Side B: 124mm and 125mm
Included in Ford, Lincoln, Mercury Solutions A & B
Used with a Small Spacer Disk on Most Balancers

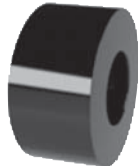

WB-L164-400-03
WB-L164-380-03
WB-L164-360-03
WB-L164-280-03

OEM Precision Collet™
Side A: 121.6mm (4.77")
Side B: 124mm and 125mm
Included in Ford, Lincoln, Mercury Solutions A & B
Used with a Small Spacer Disk on Most Balancers

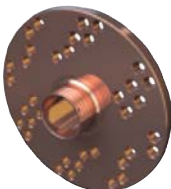

WB-L202-400-06
WB-L202-380-06
WB-L202-360-06
WB-L202-280-06

Centor Plate™ Heavy Duty Version
Bolt Patterns: 4x100mm, 4x4.25" (108mm) & 6x135mm, 6x5.5" (139.7mm), 8x6.5" (165.1mm) & 8x170mm.
Included in Ford, Lincoln, Mercury Solutions A, B & C
Centor Studs Sold Separately.



WB-L202-400-07
WB-L202-380-07
WB-L202-360-07
WB-L202-280-07

Centor Plate™ Heavy Duty Version
Bolt Patterns: 5x4.25" (108mm), 5x4.5" (114.3mm), 5x135mm & 5x5.5" (139.7mm)
Included in Ford, Lincoln, Mercury Solutions A, B & C
Centor Studs Sold Separately.



WB-L275-075-13

Centor Stud™ Style B
Short cone seat. Head diameter: 24.5mm; Base diameter: 24.5mm; Body length: 75mm; Total length: 92.8mm
Included in Solutions A, B & C



WB-L275-100-13

Centor Stud™ Style A
Cone seat. Head diameter: 20.9mm; Base diameter: 20.9mm; Body length: 100mm; Total length: 117.8mm
Included in Solutions A, B & C



WB-V760-400-01
WB-V760-380-01
WB-V760-360-01
WB-V760-280-01

Truck Step Cone
Step 1: 133.35mm (GM 10x7.25"); Step 2: 138.75mm (Ford 10x7.25"); Step 3: 142mm (Ford 8x200mm); Step 4: 170mm (Ford 8x225mm + Ford & Dodge 10x225mm); *Requires a spacer disk such as the Universal Spacer Disk (WB-V790-xxx-05), or standard Large Spacer Disk (WB-V190-xxx-01).* Included in Ford, Lincoln, Mercury Solution A



WB-V790-400-05
WB-V790-380-05
WB-V790-360-05
WB-V790-280-05

Universal Spacer Disk
Amazing 2-in-1 design with moveable magnetic plugs. Small and large spacer disk all in one. Works with any light truck cone or OEM Precision Collet WB-L162xxx-24 and WB-V760-xxx-01. *Recommended for balancers with a wheel lift. Without a wheel lift, order WB-L508-xxx-06 + WB-V760-xxx-01 + WB-L160-xxx-01;* Included in Ford, Lincoln, Mercury Solution A;



CenTor™ Adaptor System—For Car Dealerships

Chrysler / Dodge / Jeep

See individual parts on the following page.

WB-L530-400-01 **Balancing Adaptor System *Solution A***

WB-L530-380-01

WB-L530-360-01

WB-L530-280-01

SYSTEM INCLUDES:

OEM Precision Collet (WB-L162-xxx-39)

OEM Precision Collet (WB-L162-xxx-22)

OEM Precision Collet (WB-L162-xxx-40)

OEM Precision Collet (WB-L162-xxx-41)

CenTor Plate (WB-L202-xxx-11)

CenTor Plate (WB-L205-xxx-19)

CenTor Plate (WB-L206-xxx-11)

CenTor Stud “A” (WB-L275-100-13) - 8 pieces

CenTor Stud “B” (WB-L275-075-11) - 8 pieces

Application Chart (WB-M299-001-12)

WB-L530-400-02 **Balancing Adaptor System *Solution B***

WB-L530-380-02

WB-L530-360-02

WB-L530-280-02

SYSTEM INCLUDES:

CenTor Plate (WB-L202-xxx-11)

CenTor Plate (WB-L205-xxx-19)

CenTor Plate (WB-L206-xxx-11)

CenTor Stud “A” (WB-L275-100-13) - 8 pieces

CenTor Stud “B” (WB-L275-075-11) - 8 pieces

Application Chart (WB-M299-001-12)

Looking for a different Dealership Adaptor System?

- Acura • Audi • BMW • Chrysler • Dodge • Ford • GM • Honda • Infiniti • Jaguar
- Jeep • Land Rover • Lexus • Lincoln • Mercedes-Benz • Mercury
- Mini • Nissan • Scion • Smart • Subaru • Toyota • VW • More!

Just give us a call: 800-321-8173 • SVI has it available!

CenTor™ Adaptor System—For Car Dealerships

Chrysler / Dodge / Jeep - Individual Parts for Systems

	<p>WB-L162-400-39 WB-L162-380-39 WB-L162-360-39 WB-L162-280-39</p>	<p>OEM Precision Collet™ Side A: 56.5, 57mm, 58mm Side B: 65mm Included in Chrysler / Dodge / Jeep Solution A</p>
	<p>WB-L162-400-22 WB-L162-380-22 WB-L162-360-22 WB-L162-280-22</p>	<p>OEM Precision Collet™ Side A: 66.5mm, 67mm Side B: 71.5mm Included in Chrysler / Dodge / Jeep Solution A</p>
	<p>WB-L162-400-40 WB-L162-380-40 WB-L162-360-40 WB-L162-280-40</p>	<p>OEM Precision Collet™ Side A: 77.8mm Side B: 84mm, 85mm Included in Chrysler / Dodge / Jeep Solution A</p>
	<p>WB-L162-400-41 WB-L162-380-41 WB-L162-360-41 WB-L162-280-41</p>	<p>OEM Precision Collet™ Side A: 87mm Side B: 4.77" (121.16mm) Included in Chrysler / Dodge / Jeep Solution A</p>
	<p>WB-L202-400-11 WB-L202-380-11 WB-L202-360-11 WB-L202-280-11</p>	<p>CenTor Plate™ Heavy Duty Version Bolt Patterns: 4x100mm, 4x4.5" (114.3mm) & 8x6.5" (165.1mm) Included in Chrysler / Dodge / Jeep Solutions A & B <i>CenTor Studs Sold Separately.</i></p>
	<p>WB-L205-400-19 WB-L205-380-19 WB-L205-360-19 WB-L205-280-19</p>	<p>CenTor Plate™ Heavy Duty Version Bolt Patterns: 5x100mm, 5x110mm, 5x115mm, 5x120mm, 5x4.75" (120.65mm), 5x5" (127mm), 5x5.5" (139.7mm) Included in Chrysler / Dodge / Jeep Solutions A & B <i>CenTor Studs Sold Separately.</i></p>
	<p>WB-L206-400-11 WB-L206-380-11 WB-L206-360-11 WB-L206-280-11</p>	<p>CenTor Plate™ Heavy Duty Version Bolt Patterns: 6x115mm, 6x120mm, 6x5" (127mm), 6x132mm & 6x5.5 (139.7mm) Included in Chrysler / Dodge / Jeep Solutions A & B <i>CenTor Studs Sold Separately.</i></p>
	<p>WB-L275-075-13</p>	<p>CenTor Stud™ Style B Short cone seat. Head diameter: 24.5mm; Base diameter: 24.5mm; Body length: 75mm; Total length: 92.8mm Included in Chrysler / Dodge / Jeep Solutions A & B</p>
	<p>WB-L275-100-13</p>	<p>CenTor Stud™ Style A Cone seat. Head diameter: 20.9mm; Base diameter: 20.9mm; Body length: 100mm; Total length: 117.8mm Included in Chrysler / Dodge / Jeep Solutions A & B</p>



SpeedNut™

To determine correct part number for your Wheel Balancer model, please see the following pages, as some models are listed.

- Don't see your model listed? Please specify model # when ordering.

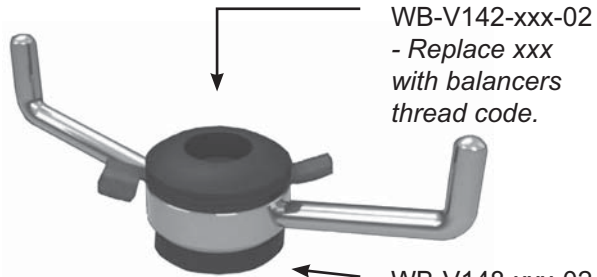

WB-V142-xxx-02
- Replace xxx
with balancers
thread code.

SpeedNut Steel — With Thrust Bearing

Thrust Bearing (Provides huge increase in torque without further operator effort).

Threaded Jaw Set (Modern extra torque design).

Ergonomic Release Lever (Comfortable for the operator).

Built-In Turning Handles (Faster to use).

- Includes Pressure Ring

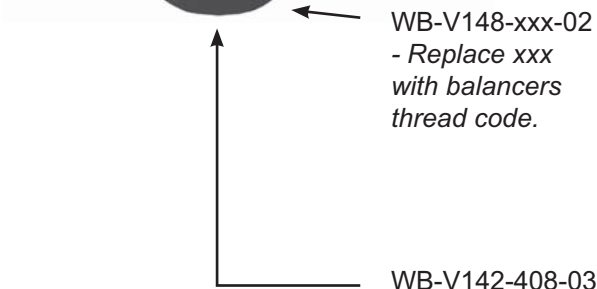

WB-V148-xxx-02
- Replace xxx
with balancers
thread code.

SpeedNut KIT Steel — With Thrust Bearing

Thrust Bearing (Provides huge increase in torque without further operator effort).

Threaded Jaw Set (Modern extra torque design).

Ergonomic Release Lever (Comfortable for the operator).

Built-In Turning Handles (Faster to use).

- Includes Pressure Ring, Pressure Cup and Rubber Cap

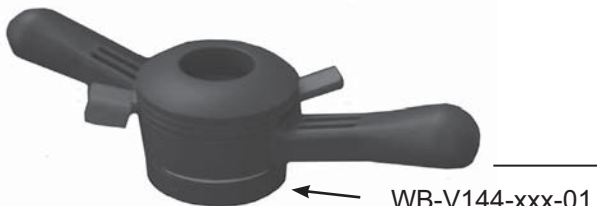

WB-V142-408-03

SpeedNut Steel — With Thrust Bearing

Special Version For Hunter

Thrust Bearing (Provides huge increase in torque without further operator effort).

Threaded Jaw Set (Modern extra torque design).

Ergonomic Release Lever (Comfortable for the operator).

Built-In Turning Handles (Faster to use).

- Includes OEM Pressure Ring and Pressure Cup

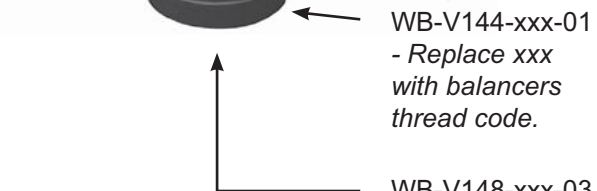

WB-V144-xxx-01
- Replace xxx
with balancers
thread code.

SpeedNut Composite

Threaded Jaw Set (Modern extra torque design).

Ergonomic Release Lever (Comfortable for the operator).

- Includes Pressure Ring

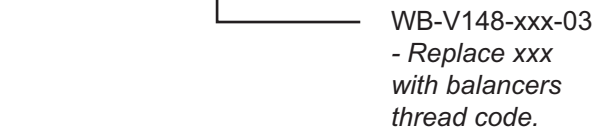

WB-V148-xxx-03
- Replace xxx
with balancers
thread code.

SpeedNut KIT Composite

Threaded Jaw Set (Modern extra torque design).

Ergonomic Release Lever (Comfortable for the operator).

- Includes Pressure Ring, Pressure Cup and Rubber Cap

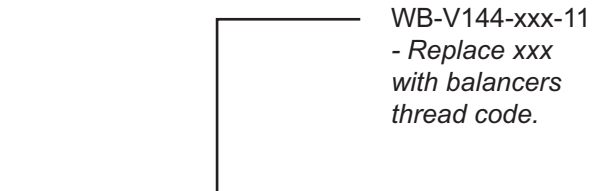

WB-V144-xxx-11
- Replace xxx
with balancers
thread code.

SpeedNut Composite With Turning Handles

Threaded Jaw Set (Modern extra torque design).

Ergonomic Release Lever (Comfortable for the operator).

Built-In Turning Handles (Faster to use).

- Includes Pressure Ring

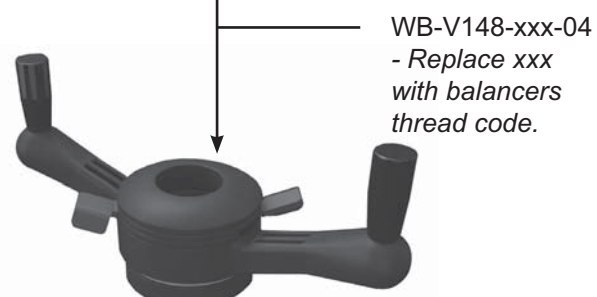

WB-V148-xxx-04
- Replace xxx
with balancers
thread code.

SpeedNut KIT Composite With Turning Handles

Threaded Jaw Set (Modern extra torque design).

Ergonomic Release Lever (Comfortable for the operator).

Built-In Turning Handles (Faster to use).

- Includes Pressure Ring, Pressure Cup and Rubber Cap

Accessories Fit SpeedNut™ and QuickNut



WB-M140-000-01

Pressure Ring *Turned Nylon*

Fits SpeedNut, as well as Haweka QuickNut.

Turned from solid Nylon 6/6.

Best choice for steel SpeedNut/QuickNut, as well as customers living at high altitude with very dry and cold weather.



WB-M140-000-02

Pressure Cup *Composite*

Fits SpeedNut, as well as Haweka QuickNut. Diameter 4.92" (125mm). Much stronger than competitor's, which helps to ensure the wheel is forced straight, thereby improving balancing results. Not all Pressure Cups are made the same, but of course, CenTor Plates and SpeedPlates are a far better choice than a Pressure Cup.



WB-M140-000-03

Rubber Cap

Helps to protect the finish on aluminum wheels. Used together with Pressure Cup (WB-M140-000-02).



WB-M142-xxx-01

- Replace xxx
with balancers
thread code.

Replacement Threaded Jaw Set

Fits SpeedNut, as well as Haweka QuickNut.

Through hardened for great durability, but not as hard as the balancer's shafts, to avoid premature shaft wear.

Modern design and manufacturing method provides better grip and torque than competitor's.

**To determine correct part number for your Wheel Balancer model,
please see the following pages, as some models are listed.**

- Don't see your model listed? Please specify model # when ordering.

Call SVI today at 800-321-8173.



SpeedNut™ and More

For Wheel Balancer Models:

Accuturn	Models 5100/5600 (serial # 51-0623 to 51-1457) / 5800 / 6000
Beissbarth	All Models
Corghi	All Models
Faip	All Models
Hunter	Models 700 / DSP9500 (1990-1992) With fine thread
M & B Bear	All Models
Sicam	All Models



WB-V142-403-02 **SpeedNut Steel — With Thrust Bearing**
• Includes Pressure Ring

WB-V148-403-02 **SpeedNut KIT Steel — With Thrust Bearing**
• Includes Pressure Ring, Pressure Cup, and Rubber Cap



WB-V144-403-01 **SpeedNut Composite**
• Includes Pressure Ring

WB-V148-403-03 **SpeedNut KIT Composite**
• Includes Pressure Ring, Pressure Cup, and Rubber Cap



WB-V144-403-11 **SpeedNut Composite With Turning Handles**
• Includes Pressure Ring

WB-V148-403-04 **SpeedNut KIT Composite With Turning Handles**
• Includes Pressure Ring, Pressure Cup, and Rubber Cap



WB-M142-403-01 **Threaded Jaw Set Replacement Part**
Fits SpeedNut, as well as Haweka QuickNut

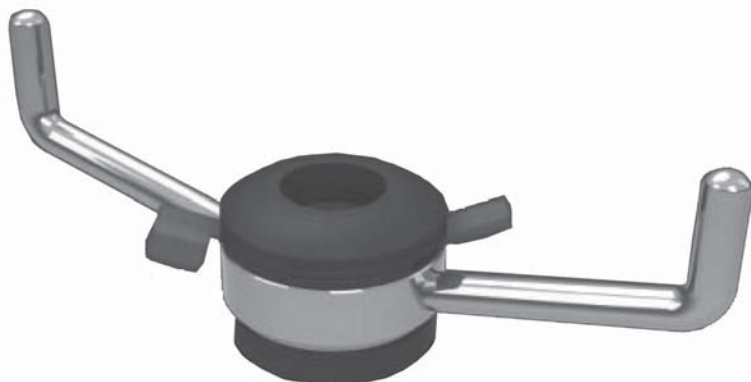

Don't see your model listed?

Call SVI and we'll help match you up with the correct wheel balancer accessories!

Call today: 800-321-8173

SpeedNut™ and More

For Wheel Balancer Models:

Accuturn	Models 1250 / 12960 / 1450 / 1550 / 1650 / 1850
Bear	Models 80-1010 / 80-1011 / 80-1012 / 80-1013
Bosch USA	Models 310 / 410 / 520 / 720 / 820HD
CEMB	All Models
Coats	Models XR1750 / XR1800 / XR1850
FMC	All Models
John Bean	Models 3.2 / 3.3 / 3.5 / 5.1 / 5.7 / 6.6 / 7.5 / 7.6
Ravaglioli	All Models
Werther	Models Altair / Orion / Polaris / Pulsar / Pulsar2 / Quasar / Vega



WB-V142-404-02 **SpeedNut Steel** — *With Thrust Bearing*
• Includes Pressure Ring



WB-V148-404-02 **SpeedNut KIT Steel** — *With Thrust Bearing*
• Includes Pressure Ring, Pressure Cup, and Rubber Cap



WB-V144-404-01 **SpeedNut Composite**
• Includes Pressure Ring



WB-V148-404-03 **SpeedNut KIT Composite**
• Includes Pressure Ring, Pressure Cup, and Rubber Cap



WB-V144-404-11 **SpeedNut Composite With Turning Handles**
• Includes Pressure Ring



WB-V148-404-04 **SpeedNut KIT Composite With Turning Handles**
• Includes Pressure Ring, Pressure Cup, and Rubber Cap

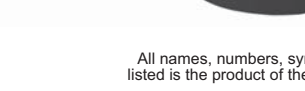

WB-M142-404-01 **Threaded Jaw Set Replacement Part**
Fits SpeedNut, as well as Haweka QuickNut



Don't see your model listed?

Call SVI and we'll help match you up with the correct wheel balancer accessories!

Call today: 800-321-8173



SpeedNut™ and More

For Wheel Balancer Models:

Accuturn	Models 1200 / 1220 / 1400 / 1420 / 1500 / 1520 / 1820
Bear	Models 80-303
Hofmann	All Models
John Bean	Models 8.5 / 8.6 / 8.7 / 9.7 / BFH800 / BFH1000 / VPI Series
Snap-On	All Models



WB-V142-405-02 **SpeedNut Steel — With Thrust Bearing**
• Includes Pressure Ring

WB-V148-405-02 **SpeedNut KIT Steel — With Thrust Bearing**
• Includes Pressure Ring, Pressure Cup, and Rubber Cap



WB-V144-405-01 **SpeedNut Composite**
• Includes Pressure Ring

WB-V148-405-03 **SpeedNut KIT Composite**
• Includes Pressure Ring, Pressure Cup, and Rubber Cap



WB-V144-405-11 **SpeedNut Composite With Turning Handles**
• Includes Pressure Ring

WB-V148-405-04 **SpeedNut KIT Composite With Turning Handles**
• Includes Pressure Ring, Pressure Cup, and Rubber Cap



WB-M142-405-01 **Threaded Jaw Set Replacement Part**
Fits SpeedNut, as well as Haweka QuickNut

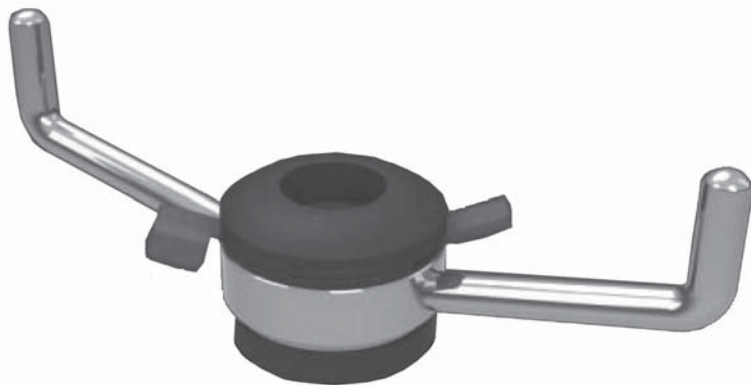

Don't see your model listed?

Call SVI and we'll help match you up with the correct wheel balancer accessories!

Call today: 800-321-8173

SpeedNut™ and More

For Wheel Balancer Models:

For Hunter Models DSP7700 / DSP8500 / DSP9000 / DSP9100 / DSP9200 /
DSP9500 / DSP9600 / DSP9700 / DSP9200 / DSP9600



WB-V142-408-02 **SpeedNut Steel — With Thrust Bearing**
• Includes Pressure Ring

WB-V148-408-02 **SpeedNut KIT Steel — With Thrust Bearing**
• Includes Pressure Ring, Pressure Cup, and Rubber Cap



WB-V144-408-01 **SpeedNut Composite**
• Includes Pressure Ring

WB-V148-408-03 **SpeedNut KIT Composite**
• Includes Pressure Ring, Pressure Cup, and Rubber Cap



WB-V144-408-11 **SpeedNut Composite With Turning Handles**
• Includes Pressure Ring

WB-V148-408-04 **SpeedNut KIT Composite With Turning Handles**
• Includes Pressure Ring, Pressure Cup, and Rubber Cap



WB-M142-408-01 **Threaded Jaw Set Replacement Part**
Fits SpeedNut, as well as Haweka QuickNut

SpeedNut™ and More

For Wheel Balancer Model:

For Hunter Model GSP9700

WB-V142-408-02 **SpeedNut Steel — With Thrust Bearing**
• Includes Pressure Ring

WB-V148-408-02 **SpeedNut KIT Steel — With Thrust Bearing**
• Includes Pressure Ring, Pressure Cup, and Rubber Cap

WB-V142-408-03 **SpeedNut Steel — With Thrust Bearing (Special)**
• Special version: Use OEM Pressure Ring and Cup



WB-M142-408-01 **Threaded Jaw Set Replacement Part**
Fits SpeedNut, as well as Haweka QuickNut

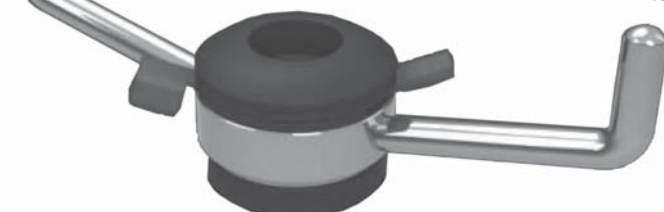



SpeedNut™ and More

For Wheel Balancer Models:

For Coats Models 700 / 850 / 1000 / 1001 / 1004 / 1025 / 1050 / 1055 / 1250
(Models with Coats 40mm over-shaft)

For Coats Models 775 / 875 / 1175



WB-V142-488-02 **SpeedNut Steel** — With Thrust Bearing
• Includes Pressure Ring



WB-V148-488-02 **SpeedNut KIT Steel** — With Thrust Bearing
• Includes Pressure Ring, Pressure Cup, and Rubber Cap



WB-V144-488-01 **SpeedNut Composite**
• Includes Pressure Ring



WB-V148-488-03 **SpeedNut KIT Composite**
• Includes Pressure Ring, Pressure Cup, and Rubber Cap

WB-V144-488-11 **SpeedNut Composite With Turning Handles**
• Includes Pressure Ring

WB-V148-488-04 **SpeedNut KIT Composite With Turning Handles**
• Includes Pressure Ring, Pressure Cup, and Rubber Cap

WB-M142-488-01 **Threaded Jaw Set Replacement Part**
Fits SpeedNut, as well as Haweka QuickNut

SpeedNut™ and More

For Wheel Balancer Models:

For Coats Models 700 / 850 / 1000 / 1001 / 1004 / 1025 / 1050 / 1055 / 1250
(Models with Coats 28.56 course Acme stub thread)

WB-V142-288-02 **SpeedNut Steel** — With Thrust Bearing
• Includes Pressure Ring

WB-V148-288-02 **SpeedNut KIT Steel** — With Thrust Bearing
• Includes Pressure Ring, Pressure Cup, and Rubber Cap

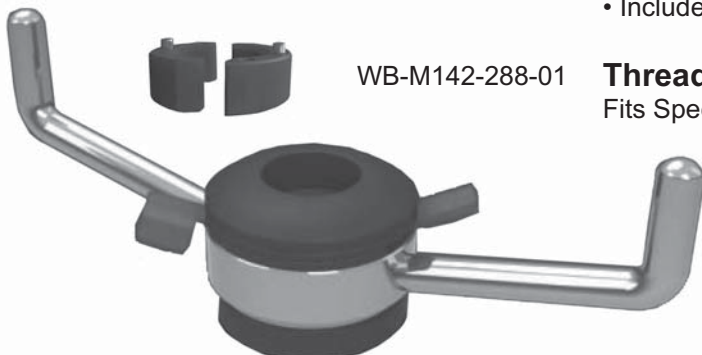

WB-M142-288-01 **Threaded Jaw Set Replacement Part**
Fits SpeedNut, as well as Haweka QuickNut

Don't see your model listed?
Call SVI and we'll help match you up with the correct wheel balancer accessories!
Call today: 800-321-8173

SpeedPlate™ System

Made in USA



The Fastest Wheel Balancing Adaptor On The Market!

No need to struggle with finding the correct bolt pattern on a chart.

Infinitely Adjustable To Fit Bolt Patterns From 92mm To 185mm!

Simply rotate the handle which rotates the 4, 5 or 6 Centering Disks, with attached color anodized Torque Studs™.

Made For High Volume Tire Shops!

Superior engineering and construction ensures this adaptor can handle the daily abuse of high volume tire shops.

Superior Balancing Results!

Custom designed Torque Stud™ spring system beats the competition hands down with superior weight repeatability and angle repeatability. That's what wheel balancing is all about.

Available In 4, 5 & 6 Lug Versions!

Blue color for 4 lug/8 lug wheels, red color for 5 lug wheels and green color for 6 lug wheels. It's that easy!

Highest Grade Aircraft Aluminum Construction!

Strongest aircraft aluminum available ensures super high strength combined with light weight – just 2kg (4.4 lbs).

For Most Wheel Balancer Models!

Available to fit wheel balancers with 28mm, 36mm, 38mm and 40mm diameter shafts.

Insanely Accurate Products™ by Vibration Solutions

Notice the difference

Get results!

Don't get caught buying a competitor's version with a plastic centering disk. No skimping on materials here;

SpeedPlates™ use aircraft aluminum for highest strength, turn and precision mill for accuracy and hard coat anodize for durability.

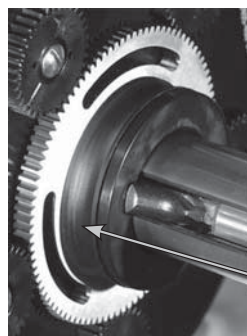

Adjustment to different bolt patterns is accomplished at lightning speed by rotating the SpeedPlate's comfortable turning handle. There is no need for a locking device.

Just squeeze the handle!

SpeedPlate™ Turning Handle



SpeedPlate™ System (Also check out our **Combination SpeedPlate** and **Centor** Systems)

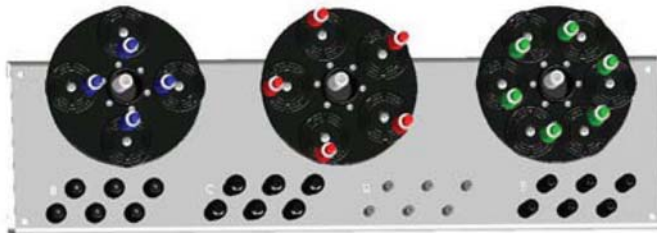

SpeedPlate™ System – Complete Kit

Covers 99% of all passenger cars, crossovers, SUVs and light trucks on the market.

Your choice:

40mm balancer shaft WB-V400-400-02

28mm balancer shaft WB-V400-280-02

INCLUDES:

SpeedPlates:

- 4-Lug SpeedPlate (Blue) - WB-V404-xx0-01,
- 5-Lug SpeedPlate (Red) - WB-V405-xx0-01,
- 6-Lug SpeedPlate (Green) - WB-V406-xx0-01;

Torque Tips:

- B-Style (6 Pieces) - WB-V265-030-01,
- C-Style (6 Pieces) - WB-V265-060-04
- E-Style (6 Pieces) - WB-V265-055-05

Storage Solution #5 (wall mt.) WB-M280-000-21

Application Chart & User Manual:

WB-M499-001-01

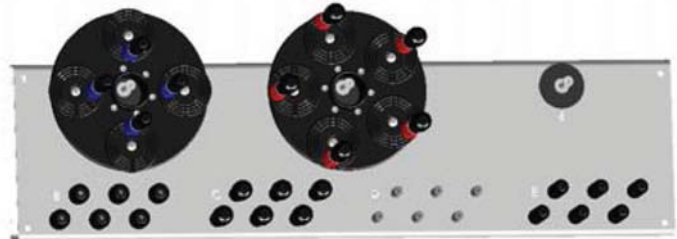

SpeedPlate™ System – Lite Kit

Covers 99% of all 4-lug and 5-lug passenger cars, crossovers, SUVs and light trucks on the market.

Your choice:

40mm balancer shaft: WB-V400-400-04

28mm balancer shaft: WB-V400-280-04

INCLUDES:

SpeedPlates:

- 4-Lug SpeedPlate (Blue) - WB-V404-xx0-01,
- 5-Lug SpeedPlate (Red) - WB-V405-xx0-01,

Torque Tips:

- B-Style (6 Pieces) - WB-V265-030-01,
- C-Style (6 Pieces) - WB-V265-060-04
- E-Style (6 Pieces) - WB-V265-055-05

Storage Solution #5 (wall mt.) WB-M280-000-21

Application Chart & User Manual:

WB-M499-001-01

**For John Bean, Hofmann and Snap-On Wheel Balancers with PowerClamp Shaft, order:
Complete System WB-V400-818-02 or Lite System WB-V400-818-04**



SpeedPlate™ (4 Lug)

40mm shaft:
WB-V404-400-01

28mm shaft:
WB-V404-280-01



SpeedPlate™ (5 Lug)

40mm shaft:
WB-V405-400-01

28mm shaft:
WB-V405-280-01



SpeedPlate™ (6 Lug)

40mm shaft:
WB-V406-400-01

28mm shaft:
WB-V406-280-01

The SpeedPlate™ System is:

- The most accurate adjustable adaptor
- The strongest (drop test)
- The most durable
- The fastest to use
- The most comfortable to use

See the following page for Torque Tips (sold separately)

SpeedPlate™ System — Torque Tips

Torque Tips (Standard)



Style B Short Cone Seat
Used mostly on light truck steel wheels.
(Total length is 75mm).
Ø24.5 x 30mm **WB-V265-030-01**



Style E Cone Seat
Used mostly for passenger car and SUV
wheels. (Total length is 100mm).
Ø19 x 55mm **WB-V265-055-05**



Style C Ball Seat
For most wheels and necessary on
Acura, Audi, Honda, Mercedes, Porsche,
and VW. (Total length is 105mm).
Ø24.5 x 60mm **WB-V265-060-04**

Torque Tips (Optional)



Style D Range Rover Taper
Used only for old Range Rover model.
(Total length is 75mm).
Ø34 x 30mm **WB-V265-030-02**



Style C Ball Seat
For most wheels and necessary on
Acura, Audi, Honda, Mercedes, Porsche,
and VW. (Total length is 85mm).
Ø24.5 x 40mm **WB-V265-040-04**



Style E Cone Seat
Used mostly for passenger car and SUV
wheels. (Total length is 100mm).
Ø19 x 40mm **WB-V265-040-05**



Style E Cone Seat
Used mostly for passenger car and SUV
wheels. (Total length is 110mm).
Ø19 x 70mm **WB-V265-070-05**



WB-M280-000-21

Storage Solution #5 *Wall Board for SpeedPlate System*
Hangs on wall or Storage Solution #6. Holds SpeedPlates and
Torque Tips.



Combination System — SpeedPlate™ and CenTor

This combination system covers over 99% of all passenger cars, crossovers, SUVs, and light trucks on the market. Available for 40mm or 28.56mm shaft wheel balancers.

- The SpeedPlate system is used for fast and accurate balancing of 4-lug and 5-lug passenger car, crossover and other light weight wheels.
- The CenTor Plates are used to balance larger and heavier 5-lug, 6-lug, and 8-lug SUV and light truck wheels.

Call to Order the Combo System!

For 40mm shaft: WB-V400-400-05

For 28.56mm shaft: WB-V400-280-05

- Also Available for John Bean, Hofmann and Snap-On Wheel Balancers with Power Clamp Shaft: WB-V400-818-05

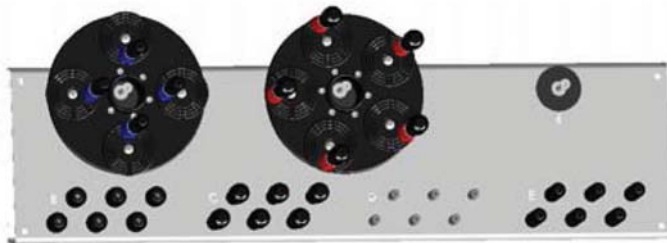

SpeedPlate™ System Products

INCLUDES:

SpeedPlates 4-Lug SpeedPlate (Blue) WB-V404-xx0-01
5-Lug SpeedPlate (Red) WB-V405-xx0-01

Torque Tips B-Style (6 pieces) - WB-V265-030-01
C-Style (6 pieces) - WB-V265-060-04
E-Style (6 pieces) - WB-V265-055-05

Storage Solution #5 WB-M280-000-21 (wall mount)

Application Chart & User Manual WB-M499-001-01



CenTor™ Adaptor System - SUV / Light Truck

INCLUDES:







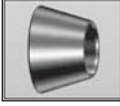

CenTor Plates SUV/Lt Trk Plate #1 5-lug WB-L201-xx0-02
SUV/Lt Trk Plate #2 6/8-Lug WB-L205-xx0-10

CenTor Studs B Style (6 pieces) - WB-L275-075-11
A Style (6 pieces) - WB-L275-100-13









Application Chart & User Manual M299-001-07

Storage Solution #4 M280-000-20 (wall mount)

Centering Cones

SVI #	Size	Description	Fits Shaft Size:	
WB-1500-32	1.68" - 2.56" (43 mm - 65 mm)	Satin finish taper, Super finish bore	40 mm	
WB-1500-22	Low Taper Cone	Available on Request	38 mm	
WB-1500-12		Available on Request	36 mm	
WB-1500-02		Available on Request	28 mm	
WB-1500-33	2.12" - 3.15" (54 mm - 80 mm)	Satin finish taper, Super finish bore	40 mm	
WB-1500-23	Low Taper Cone	Available on Request	38 mm	
WB-1500-13		Available on Request	36 mm	
WB-1500-03		Available on Request	28 mm	
WB-1500-34	2.91" - 3.94" (74 mm - 100 mm)	Satin finish taper, Super finish bore	40 mm	
WB-1500-24	Low Taper Cone	Available on Request	38 mm	
WB-1500-14		Available on Request	36 mm	
WB-1500-04		Available on Request	28 mm	
WB-1500-35	1.67" - 3.15" (42.5 mm - 80 mm)	Satin finish taper, Super finish bore	40 mm	
WB-1500-25	Low Taper Cone	Available on Request	38 mm	
WB-1500-15		Available on Request	36 mm	
WB-1500-05		Available on Request	28 mm	
WB-1500-36	2.91" - 4.39" (74 mm - 111.5 mm)	Satin finish taper, Super finish bore	40 mm	
WB-1500-26	High Taper Cone	Available on Request	38 mm	
WB-1500-16		Available on Request	36 mm	
WB-1500-06		Satin finish taper, Super finish bore	28 mm	
WB-1500-37	2.74" - 5.18" (95 mm - 131.5 mm)	Satin finish taper, Super finish bore	40 mm	
WB-1500-27	High Taper Cone	Available on Request	38 mm	
WB-1500-17		Available on Request	36 mm	
WB-1500-07		Satin finish taper, Super finish bore	28 mm	
WB-1500-38	4.72" - 6.85" (120 mm - 174 mm) Large Truck Cone, traditional double sided design	Standard finish taper, Standard fin. bore	40 mm	
WB-1500-28		Standard finish taper, Standard fin. bore	38 mm	
WB-1500-18		Standard finish taper, Standard fin. bore	36 mm	
WB-1500-08		Standard finish taper, Standard fin. bore	28 mm	
WB-1500-39	Lexus & Toyota Centering Cone	For Lexus & Toyota	40 mm	
WB-1500-29			38 mm	
WB-1500-19			36 mm	
WB-1500-09			28 mm	
WB-1500-40	Infinity & Nissan centering Cone	For Infinity & Nissan	40 mm	
WB-1500-30			38 mm	
WB-1500-20			36 mm	
WB-1500-10			28 mm	

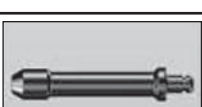

CenTor™ Studs	
	WB-1550-00 Style B, Short Cone Seat (25.5mm). Bolt-in style. 75 mm long body and 92 mm overall length. Used mostly for light truck steel wheels. Fits Fixed Adaptor plates
	WB-1550-01 Style A. Cone seat (20.9 mm). Bolt-in style. 85 mm long body and 102 mm overall length. Used mostly for passenger car and SUV wheels. Fits Fixed Adaptor plates
	WB-1550-04 Style A. Cone Seat (20.9 mm). Plug-In Style. 68 mm long body and 85 mm overall length. Used mostly for passenger car and SUV wheels. Optional for old balancers with very short shafts. Fits Plug-in Adaptor plates.
	WB-1550-05. Style B. Short cone seat (24.5mm). Plug-in Style. 75 mm long body and 92 mm overall length. Used mostly for light truck steel wheels. Standard with Adaptor System. Fits Plug-in Adaptor plates.
	WB-1550-06. Style D. Range Rover taper. Plug-in style. 75 mm long body and 92 mm overall length. Optional only for Range Rover model. Not for other Land Rover models. Fits Plug-in Adaptor plates.
	WB-1550-07 Style A. Cone seat (20.9 mm). Plug-in style. 85 mm long body and 102 mm overall length. Used mostly for passenger car and SUV wheels. Standard with Adaptor Systems. Fits Plug-in Adaptor plates
	WB-1550-08 Style C. Ball seat (24.5 mm). Plug-in style. 85 mm long body and 102 mm overall length. For Acura, Audi, Honda, Mercedes, Porsche & VW wheels with ball seat lug nuts. Standard with Adaptor system. Fits Plug-in Adaptor plates.
	WB-1550-09 Style E Cone seat (19 mm). Plug-in style. 95 mm long body and 112 mm overall length. Optional for tuner style wheels. Fits Plug-in Adaptor plates
	WB-1550-02 Style A. Cone seat (20.9 mm). Plug-in style. 100 mm long body and 117 mm overall length. Used mostly for passenger car and SUV wheels. Fits Plug-in Adaptor plates.
	WB-1550-03 Style C. Ball seat (24.5 mm). Plug-in style. 105 mm long body and 122 mm overall length. For Accura, Audi, Honda, Mercedes, Porsche * VW wheels with ball seat lug nuts. Fits Plug-in Adaptor plates.

**TERMS AND CONDITIONS OF THE
SALES ORDER
FOR SVI INTERNATIONAL, INC.**

1. **GENERAL.** The terms and conditions of sales order outlined herein shall apply to the sale by SVI INTERNATIONAL, INC. (hereinafter referred to as "Company") of the items described on the facing page (hereinafter referred to as "Merchandise") to Purchaser.
2. **DELIVERY.** Delivery shall be deemed to be complete when the Merchandise has been shipped F.O.B. Company's plants in DeKalb, Illinois, Duarte, California; and Baltimore, Maryland ("Company's plants"). Shipments are subject to delays from causes or contingencies beyond the reasonable control of the Company. When otherwise not specified, shipments will be made in standard containers via carrier which, in the judgment of the Company, will result in the most practical method. Title and right of possession will pass to the Purchaser upon receipt by the carrier at the shipping point. If a customer of the Company should specify a specific carrier's method of shipment (i.e. UPS Next Day Air) and that carrier does not perform to the customer's expectations, freight credit to a customer's account will not be issued unless the Company can first obtain a credit.
3. **RISK OF LOSS.** Identification of the Merchandise under Uniform Commercial Code (hereinafter referred to as "UCC") Section 2-501 shall take place at the moment of shipment F.O.B. Company's plants. Risk of loss shall pass to the Purchaser when the Merchandise is shipped from the Company's plants.
4. **TITLE.** Title to the merchandise shall transfer to the Purchaser when the Merchandise is shipped from the Company's plants.
5. **WARRANTIES.** The Company guarantees its products to be free from defects in workmanship and raw materials for a period of one year from date of purchase. THIS WARRANTY IS EXPRESSLY IN LIEU OF ANY AND ALL WARRANTIES EXPRESS OR IMPLIED. COMPANY DOES NOT WARRANT THE MERCHANDISE IS MERCHANTABILITY OR FIT FOR ANY PARTICULAR PURPOSE. Company's liability for breach of the terms of this Agreement, including any warranty, is limited to either refund of the invoice price of the Merchandise or at Company's option, replacement of the Merchandise free of charge, including transportation charges but not including the cost of labor. Purchaser has not relied on any statement or upon the conduct of Company with respect to the prospective use of the merchandise. Company shall not be liable for and Purchaser waives any and all claims for any loss or damage, directly or indirectly, arising from the use of the Merchandise and for punitive, incidental or consequential damages, including, but not limited to, damages to property, for loss of use, loss of time, loss of profit or loss of income. The Company does not authorize the sale of our products under any other warranty, expressed or implied.
6. **SETOFF.** All claims for money due or to become due from the Company shall be subject to deduction by the Company for any setoff or counterclaim arising out of this or any other claims of the Company or its affiliated companies, whether such setoff or counterclaim arose before or after any assignment by Purchaser.
7. **INDEMNIFICATION.** Purchaser agrees to indemnify the Company and hold it harmless from and against all claims, liability, loss, damage or expense, including reasonable counsel fees, arising from or by reason of any modifications or alterations made by Purchaser. If a customer of the Company modifies or alters any part, in any manner whatsoever, or uses any part in departure from recommended performance specifications, said customer agrees to indemnify and hold the Company harmless from and against all liability and expenses based on damage to property or injury to or death of any person arising out of or attributable to such modified or altered part. Further, the Company will not accept any such modified or altered part for credit to a customer's account.
8. **FREIGHT POLICY.** Freight charges on individual orders less than \$3,000 in net value are prepaid and added to invoice or collect F.O.B. shipping point. Freight charges (standard ground service and continental US only) on individual orders more than \$3,000 net value are paid by the Company F.O.B. shipping point. Note: customers with C.O.D. terms are responsible for all carrier C.O.D. fees regardless of order net value.
9. **RETURN POLICY.** To return parts for credit or inspection Purchaser must first contact the Company to obtain a Return Goods Authorization number (RGA#). Once Purchaser has obtained an RGA# the parts can be returned freight prepaid only. The RGA# must be on the outside of the container in a highly visible location. All parts must be returned freight prepaid and the shipment must include a letter of explanation giving the specific reason for return including details as to the conditions under which the part or parts operated. Note: parts returned without an RGA#, freight collect or without written explanation may be refused. Parts which have been used in any way or manner, including any installation or incorporation into a lift or hoist, shall NOT be eligible for return whether or not an RGA has been assigned.
10. **RESTOCK CHARGE.** Returns are subject to up to twenty-five (25%) restocking charge. Refusals are subject to the same restocking charge plus the cost of outbound and return freight charges and/or fees incurred by the Company due to shipment refusal.
11. **PRICES AND PAYMENTS.** All prices are subject to change without notice. All prices are F.O.B. shipping point. The Company standard terms are net 30 days, C.O.D. company check, C.O.D. cash, VISA, MasterCard, Discover or American Express. However, if in the judgment of the Company, the financial condition of the Purchaser at any time does not justify shipment according to standard terms of payment, the Company may require full or partial payment in advance.
12. **INTERPRETATION.** This sales order is intended by the parties as a complete and exclusive statement of the terms of their agreement. It supersedes all prior agreements, written or oral. No course of prior dealings between the parties and no usage of the trade shall be relevant to supplement or explain any terms used in this sales order. Acceptance or acquiescence in a course of performance rendered under this purchase order shall not be relevant to determine the meaning of this sales order even though the accepting or acquiescing party has knowledge of the nature of the performance and opportunity for objection. Whenever a term defined by the UCC is used in this sales order the definition contained in the UCC shall control.
13. **MODIFICATION.** This sales order can be modified or rescinded only by a writing signed by both parties.
14. **WAIVER.** No claim or right arising out of a breach of this sales order can be discharged in whole or in part by a waiver or renunciation of the claim or right unless such waiver or renunciation is supported by consideration and is in writing signed by the aggrieved party.
15. **ASSIGNMENT.** No right or interest in this sales order shall be assigned by either party without the written consent of the other and no delegation of any obligation owed, or of the performance of any obligation by either the Company or Purchaser shall be made without the written consent of the other party. Any attempted assignment or delegation not made in conformity with this paragraph shall be wholly void and totally ineffective for all purposes.
16. **TIME TO PERFORM AND BRING ACTION.** Time is of the essence of this sales order. Any action for breach of this sales order shall be commenced within two (2) years after the cause of action has accrued. Any party who loses any litigation shall reimburse the other party for costs including reasonable attorneys fees. The exclusive jurisdiction for any legal action shall be the Circuit Court of DeKalb County, Illinois.
17. **APPLICABLE LAW.** This sales order shall be governed by the UCC of Illinois as effective and in force on the date of this sales order.